

TECHNICAL INSTRUCTIONS



CAUTION: No user-serviceable parts inside. Hazardous voltage may be encountered within the chassis. Installation and Service information within this document is for use only by ALTEC sound contractors, factory authorized warranty stations and qualified service personnel.

IMPORTANT: Il est enjoint à l'utilisateur de ne pas réparer lui-même les pièces internes de l'appareil, des courants à haute tension pouvant passer à l'intérieur du châssis. Les renseignements inclus dans ce document sont destinés uniquement à l'usage des installateurs agréés des systèmes acoustiques ALTEC, des centres de réparation sous garantie autorisés, ainsi que du personnel d'entretien qualifié.

SPECIFICATIONS

| | |
|--|---|
| <p>Type:</p> <p>AC Power Requirements (2200 Main Frame with 8-Model 2275 Power Amplifiers, Model 2221 Input Card, Model 2252 Driver Card.)</p> <p>Export Conversion Voltages</p> <p>Connectors</p> <p>Controls and Indicators</p> <p>Dimensions:</p> <p>Weight</p> <p>Finish (front panel)</p> | <p>Rackmount card cage construction to accept plug-in card modules:</p> <p>1 ac primary power module 1 input module, Model 1220 or 1221 2 driver modules, Model 2250, 2250SA, 2251, 2251SA, 2252, or 2252SA 8 power amplifier modules, Model 2275</p> <p>120V AC, 50 or 60 Hz; 1100W AC line power at full power (600W) output, 1 kHz input; 660W AC line power at 1/3 power (200W) output, 1 kHz input; 360W AC line power at 1/10 power output (60W or - 10 dB from full output power), pink noise input.</p> <p>100, 120, 200, 220, 240V AC, 50 or 60 Hz</p> <p>(4) D3F Channel 1-4 Input Connectors, (XLR-type three-pin female.) (8) 1/4" TS Phone Jack Input Connectors (in pairs with each pair corresponding to an input channel). (4) 1/4" (stereo) Phone Jack Special Input/Output connectors. (2) Eight-position terminal blocks, (one "HIGH", one "COM") corresponding to the outputs of the eight possible Model 2275 Power Amplifiers. (1) Three-pin (grounded) AC power cable connector. (8) 10-positions card-edge connectors for up to eight Model 2275 Power Amplifiers. (3) 28-position card-edge connectors for the Input, Driver and Crossover Cards.</p> <p>(1) Combination AC-power-switch/circuit-breaker/pilot-lamp.</p> <p>17-5/8" (447.7 mm) L x 19" (483 mm) W x 7" (178 mm) H</p> <p>70 lb. (31.7 kg) empty; 56 lb (25.4 kg) fully loaded</p> <p>Altec Green</p> |
|--|---|

DESCRIPTION

The main frame is a rackmount card cage which accepts one primary power (ac) module, one input module, up to two driver or crossover driver modules, and up to eight power amplifier modules. Each plug-in module is inserted into the appropriate connector within the main frame, according to the functional position shown in Figure 1. A hinged panel covers the module positions after installation and adjustment.

All input/output connections are located on the rear panel. Four XLR-3 type female receptacles connect balanced signals to the selected input module. Eight 1/4" phone jacks connect up to four separate unbalanced input signals. Four special input/output stereo 1/4" phone jacks (J213, J214, J215, and J216) connect up to eight unbalanced signals directly to the driver modules. Separate output connections are provided for each power amplifier module positions.

When balanced input signals are fed to the appropriate XLR-3 type connectors, output signals may be derived at the UNBAL phone jack connectors. The eight phone jacks adjacent to the XLR-3 connectors may become *unbalanced outputs*, deriving signals from transformer secondaries of the Model 2221 Input Card Module. The four special input/output jacks may become special *outputs*, deriving signals from the high, mid, and low frequency outputs of the Model 2251 and 2251SA Crossover Driver Card Modules.

As shipped from the factory, each main frame is equipped with an ac primary power

Specifications and components subject to change without notice. Overall performance will be maintained or improved.

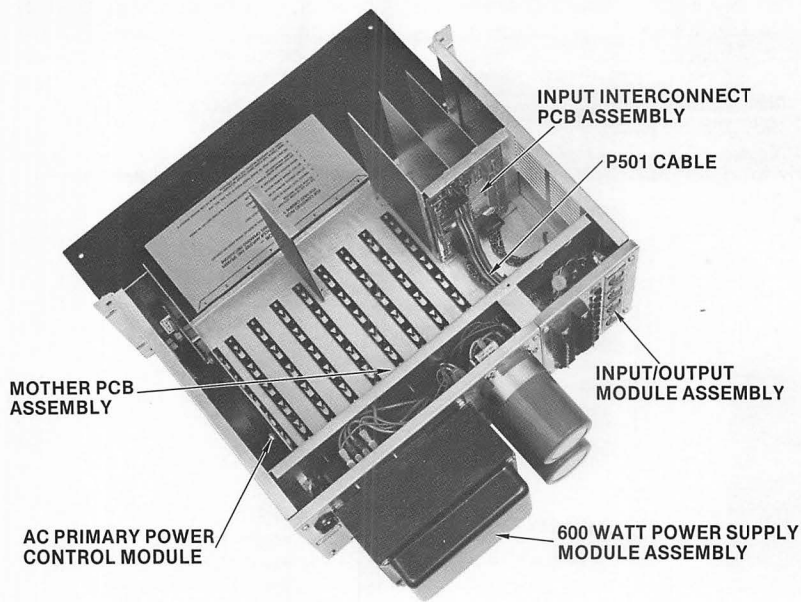

Figure 1. Location of Main Frame Assemblies

module, installed as in Figure 1. The module is equipped with an ON-OFF ac power switch (circuit breaker type) with built-in pilot lamp. A terminal strip permits strapping the power transformer primary for 100V, 120V, 200V, 220V, or 240V at 50/60 Hz; as shipped from the factory, straps are installed for 120 Vac. A fan is incorporated in the module for forced-air cooling of power amplifier modules.

INSTALLATION INSTRUCTIONS

Refer to Operating Instructions for Incremental Power System (42-02-045121) for all installation instructions, including electrical connections, alternate 50/60 Hz primary power connections, and 8-ohm conversion.

FUSE REPLACEMENT

Two fuses are located on the PCB assembly of the 600 watt power supply module. See Figure 2. If replacement is required, install an identical fuse (see **Parts List**). For access to the fuses, separate the 600 watt power supply module from the main frame, as described in appropriate removal procedures.

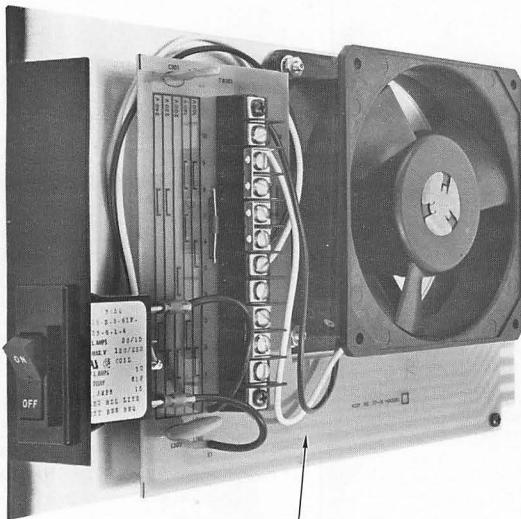

AC PRIMARY POWER CONTROL MODULE

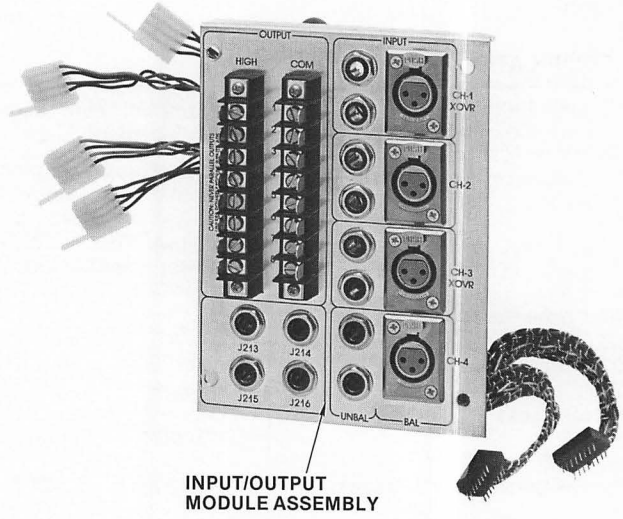

INPUT/OUTPUT MODULE ASSEMBLY

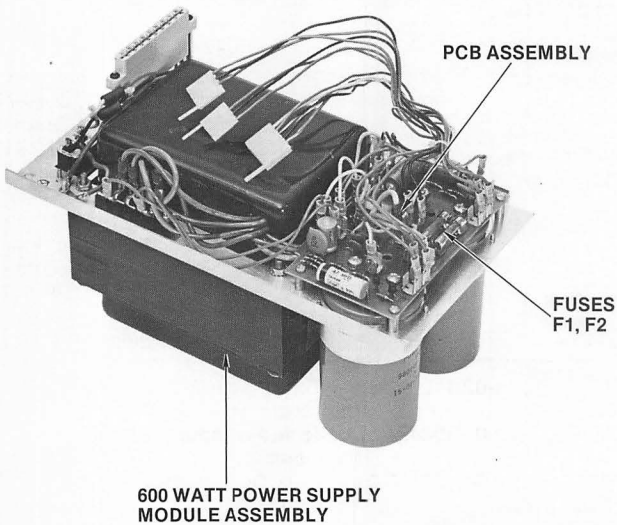

600 WATT POWER SUPPLY MODULE ASSEMBLY

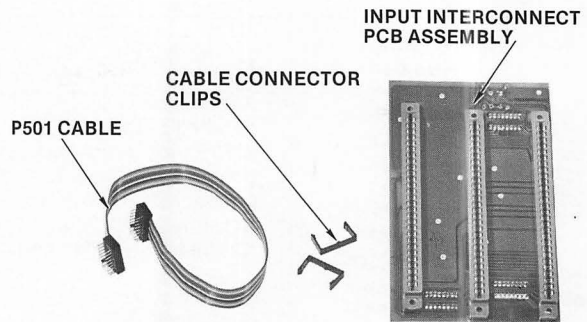

P501 CABLE

CABLE CONNECTOR CLIPS

INPUT INTERCONNECT PCB ASSEMBLY

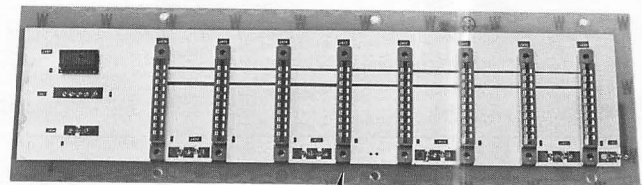

MOTHER PCB ASSEMBLY

Figure 2. Main Frame Assemblies

REMOVAL OF MAIN FRAME ASSEMBLIES

1. Turn off ac primary power to the Incremental Power System (remove ac cable from ac power source).
2. Remove four screws that secure the front panel. Open and lower front panel as shown in Figure 1.
3. Remove all card modules (input, driver, power amplifier, and ac primary power) from main frame. The ac primary power module is removed similarly to other plug-in card modules.
4. Remove four 8-32 × ¼" screws from sides of top cover, and remove one 6-32 × ¼" screw from top side of top cover. Lift front end of top cover and pull cover forward to disengage rear lip; it may be necessary to drive top cover forward by placing a screwdriver against the rear edge of the cover and striking gently with a hammer.
5. Proceed to remove the selected main frame assembly as described in the following paragraphs.

Removal of 600 Watt Power Supply Assembly

1. Remove four 8-32 × 3/8" screws that secure 600 watt power supply assembly to main frame.
2. Remove four 8-32 × 3/8" screws that secure input/output assembly to main frame.
3. Pull power supply and input/output assemblies forward to extent permitted

by wiring. Note that lower bracket engages in slot formed by structure of main frame chassis.

4. Locate and disconnect three connectors (P102, P103, and P104) at mother PCB assembly, to remove power supply assembly from main frame. Note general routing of cables to facilitate proper reconnection.
5. Reverse removal procedure for reassembly.

CAUTION

Before *tightening* screws that secure the 600 watt power supply assembly to the chassis, install ac primary power module; the connector of the ac primary power module must be in correct vertical alignment with the corresponding connector of the 600 watt power supply assembly.

Removal of Input/Output Assembly

1. Complete steps 1, 2 and 3 of removal procedure for 600 watt power supply assembly.
2. Locate two connectors (202 and P203) of input/output assembly that connect to the input interconnect PCB assembly. To avoid mixup, mark or tag each plug and receptacle to facilitate proper reconnection. Remove the plastic locking clips from the plugs and disconnect.
3. Locate four connectors (P205, P206, P207, and P208) of input/output assembly that connect to mother PCB

assembly. To avoid mixup, mark or tag each plug and receptacle to facilitate proper reconnection; also note general routing of cables. Disconnect the four plugs to separate the input/output assembly from the main frame.

4. Reverse removal procedure for reassembly.

Removal of Mother PCB Assembly

1. Remove six sheet metal screws that secure mother PCB assembly to main frame chassis.
2. If 600 watt power supply and input/output assemblies were not removed previously, tip mother PCB assembly forward to extent permitted by wiring. Disconnect all plugs from connectors of mother PCB assembly to separate the assembly from the main frame. Carefully note (or tag) plugs and connectors to facilitate proper reconnection.
3. Reverse removal procedure for reassembly.

Removal of Input Interconnect PCB Assembly

1. Remove 600 watt power supply, input/output, and mother PCB assemblies from main frame chassis, as described in preceding paragraphs.
2. Remove six sheet metal screws that secure input interconnect PCB assembly to main frame chassis.
3. Reverse removal procedures for reassembly.

PARTS LIST

MAIN FRAME

| Reference Designator | Ordering Number | Name and Description |
|----------------------|-----------------|---------------------------------------|
| — | 27-04-044955-01 | AC Primary Power Control Module |
| — | 27-04-044980-01 | Input/Output Module Assembly |
| — | 27-04-045080-01 | Input Interconnect PCB Assembly |
| — | 27-04-044978-02 | Mother PCB Assembly |
| — | 27-04-044979-01 | 600 Watt Power Supply Module Assembly |
| P501 | 60-05-121754-01 | Cable, 16 conductor, flat |
| — | 10-02-01-185 | Accessory Kit |

AC PRIMARY POWER CONTROL MODULE

| Reference Designator | Ordering Number | Name and Description |
|----------------------|-----------------|--------------------------------------|
| — | 27-01-045081-01 | AC Control PCB Assembly |
| B301 | 35-01-121520-01 | Fan, 75 CFM |
| CB301 | 51-03-121521-01 | Circuit Breaker, 12A, Lighted Rocker |

AC CONTROL PCB ASSEMBLY

| Reference Designator | Ordering Number | Name and Description |
|----------------------|-----------------|------------------------------|
| C301,302 | 15-02-121767-01 | Cap., 0.0047 μF ± 20%, 1400V |
| CR301 | 48-02-042787-01 | Rect., 1A, 400V, silicon |
| R301 | 47-01-100649-01 | Res., 1 kΩ ± 10%, 1W |
| TB301 | 21-04-121751-01 | Term. Block, 10-terminal |

INPUT/OUTPUT MODULES ASSEMBLY

| Reference Designator | Ordering Number | Name and Description |
|----------------------|-----------------|-------------------------------------|
| J201,202 | 21-02-113172-01 | Receptacle, 3-pin, XLR-3-31 |
| 203,204 | 21-01-100494-01 | Jack, 2-conductor, phone, insulated |
| J205 thru J212 | 21-01-107505-01 | Jack, 3-conductor, phone, insulated |
| J213,214, 215,216 | 60-05-121753-01 | Cable, interconnect, 16 conductor |
| P202,203 | 21-04-121616-01 | Term. Block, 8-terminal |
| TB201,202 | | |

PARTS LIST (Continued)

INPUT INTERCONNECT PBC ASSEMBLY

| Reference Designator | Ordering Number | Name and Description |
|----------------------|-----------------|--------------------------------------|
| C501,502 | 15-02-100074-01 | Cap., 0.01 μ F - 20% + 80%, 500V |
| L501,502 | 56-01-043100-01 | Choke, ferrite bead |

600 WATT POWER SUPPLY MODULE ASSEMBLY

| Reference Designator | Ordering Number | Name and Description |
|----------------------|-----------------|------------------------------------|
| — | 27-01-044963-01 | PCB Assembly 600 Watt Power Supply |
| C101,102 | 15-01-120228-01 | Cap., 9800 μ F, 100V |
| CR101 | 48-02-120247-02 | Rectifier, bridge, 12A, 200V |
| L101,102 | 56-01-044110-01 | Choke ferrite bead |
| T101 | 56-08-007609-01 | Transformer, power |
| TB101 | 21-04-121915-01 | Term. Block, 4-terminal |

PCB ASSEMBLY, MOTHER BOARD

| Reference Designator | Ordering Number | Name and Description |
|----------------------|-----------------|---------------------------------|
| C400 | 15-01-109010-01 | Cap., 18 μ F \pm 10%, 50V |
| R400 | 47-01-102334-01 | Res., 22 \pm 10%, 1/2W |

PCB ASSEMBLY, 600 WATT POWER SUPPLY

| Reference Designator | Ordering Number | Name and Description |
|----------------------|-----------------|--------------------------------------|
| C1 | 15-06-102605-01 | Cap., 0.46 μ F \pm 10%, 100V |
| C2 | 15-01-119381-01 | Cap., 200 μ F, 25V |
| C3,5,7 | 15-02-100109-01 | Cap., 0.1 μ F \pm 20%, 100V |
| C4,6 | 15-01-114213-01 | Cap., 470 μ F, 40 V |
| C8,9,10,11 | 15-02-100074-01 | Cap., 0.01 μ F - 20% + 80%, 500V |
| CR1,2,4,5,6,7,8 | 48-02-042787-01 | Rectifier, 1N4004, 1A, 400V PIV |
| CR3 | 48-01-100858-01 | Diode, zener, 12V \pm 5%, 2W |

| Reference Designator | Ordering Number | Name and Description |
|----------------------|-----------------|---|
| F1,2 | 51-04-100463-01 | Fuse, 1/2A, 3AG, 250V |
| Q1 | 48-03-119140-02 | Transistor, 2N5308, low noise, selected |
| R1 | 47-01-102114-01 | Res., 33 k Ω \pm 5%, 1/4 W |
| R2 | 47-01-102187-01 | Res., 100 k Ω \pm 10%, 1/4 W |
| R3 | 47-01-102175-01 | Res., 10 k Ω \pm 10%, 1/4 W |
| R4 | 47-01-102147-01 | Res., 47 Ω \pm 10%, 1/4 W |
| R5 | 47-01-102173-01 | Res., 6.8 k Ω \pm 10%, 1/4 W |
| SCR1 | 48-02-120246-01 | Rectifier, C103YY, 0.8A, 60V |

ACCESSORY KIT

| Quantity | Ordering Number | Name and Description |
|----------|-----------------|-------------------------------------|
| 14 | 21-01-121461-01 | Jumper Bars (for output connectors) |
| 16 | 21-02-121862-01 | Terminal Connectors, push-on |
| 1 | 24-01-045093-01 | Decal, voltage rating stickers |
| 4 | 28-09-110877-01 | Feet, rubber |

| Reference Designator | Ordering Number | Name and Description |
|----------------------|-----------------|----------------------------------|
| 1 | 60-06-121745-01 | Cord, power, 3 cond., 7 1/2 feet |
| 4 | 28-01-110143-01 | Screws, mounting, 10-32 x 5/8" |
| 4 | 28-01-110322-02 | Screws, mounting, 12-24 x 5/8" |
| 4 | 28-01-119135-01 | Screws, mounting, 8-32 x 5/8" |

| | | | | |
|----|-----|------------------|--------------|--|
| 99 | | REL FOR PILOT | | |
| 98 | | REVISIONS | | |
| 01 | | EEL FOR FEED. | 4-11-78 | |
| 02 | AWA | CHNGD PER E.C.D. | C.B. 4-26-78 | |

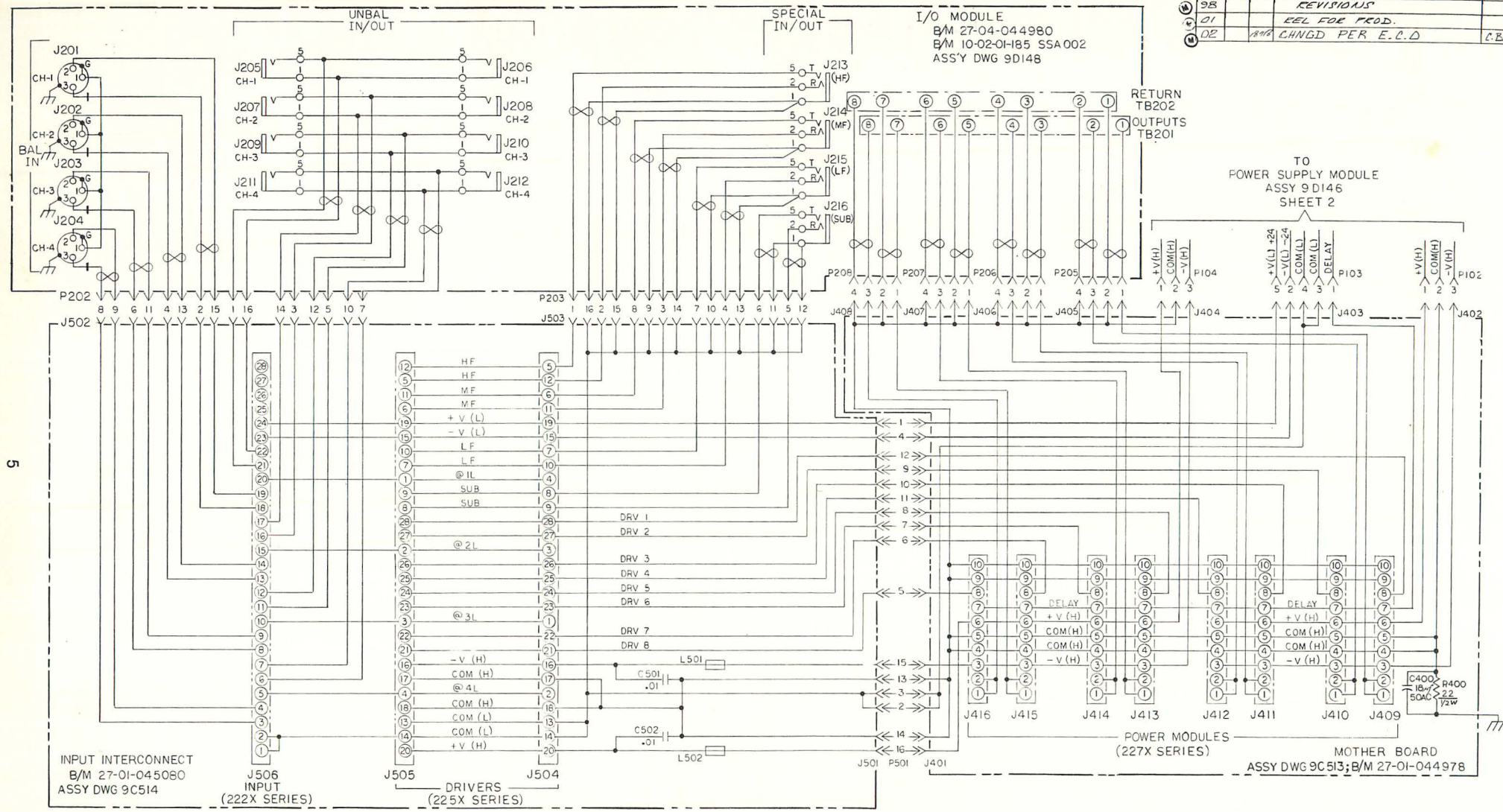

- 5 ALL CAPACITORS VALUES ARE GIVEN IN MICROFARADS
- 4 ALL RESISTORS ARE 1/4W±10%
- 3 FOR WIRE LIST SEE 9B360&9B363
- 2
- 1 FOR ASSY DWG SEE 9D144

NOTES: UNLESS OTHERWISE SPECIFIED

Figure 3. Schematic (9D145-02), Main Frame Interconnection (Sheet 1)

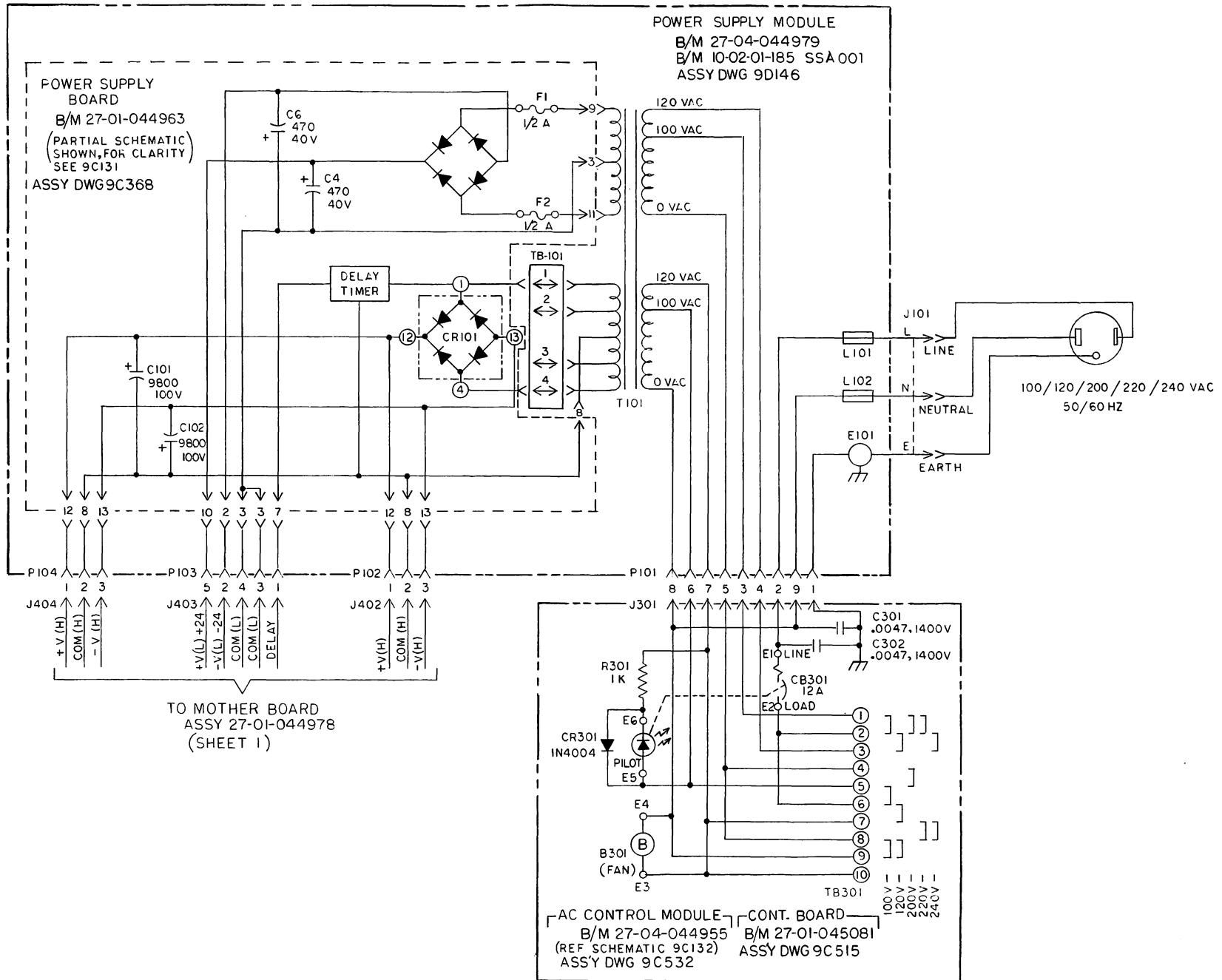
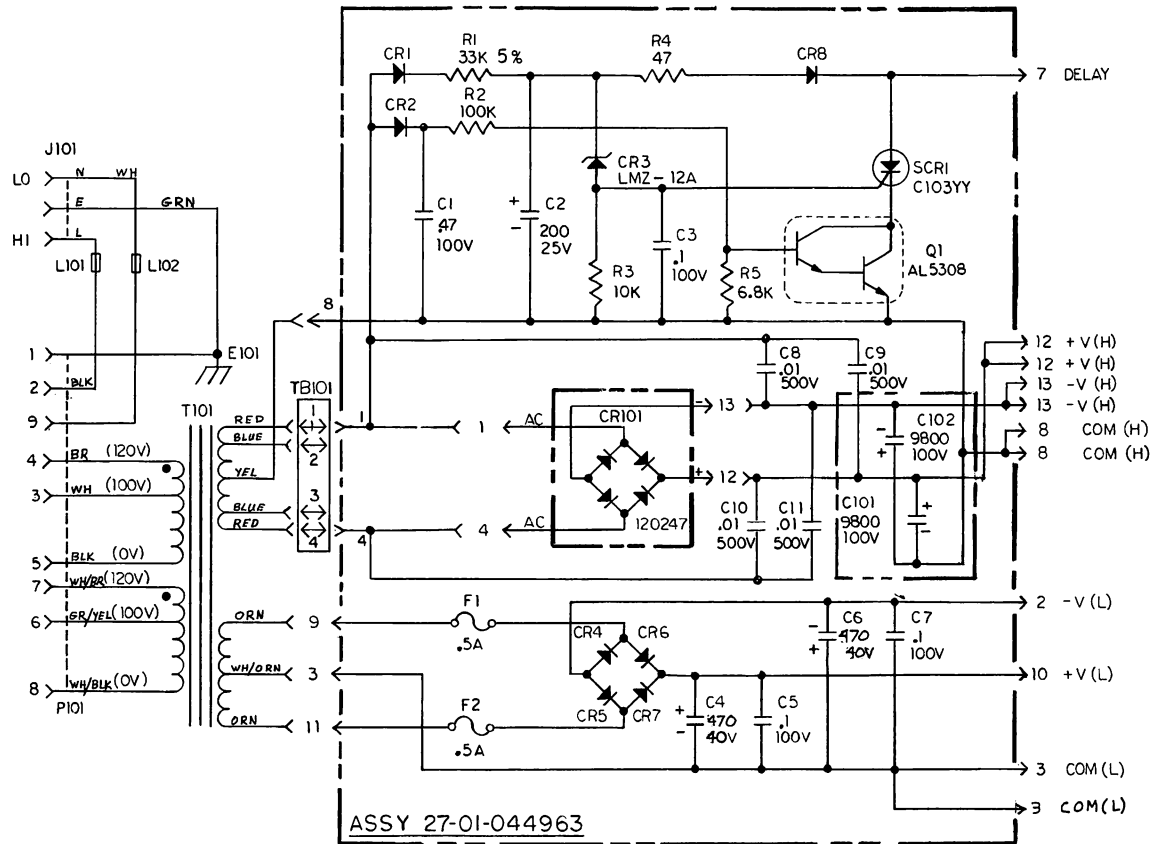

Figure 4. Schematic (9D145-02), Main Frame Interconnection (Sheet 2)

| REVISIONS | | | | | APPROVED | | |
|-----------|------|-----|---------------|-----|----------|-----|-----|
| ISSUE | ZONE | ECO | DESCRIPTION | BY | DATE | ENG | REL |
| D | | | | Law | 4-4-78 | | |
| 99 | | | REL FOR PILOT | | 2-17-78 | | |
| 01 | | | REL FOR PROD | | 4-11-78 | | |



| HIGHEST REFERENCE DESIGNATION USED | | | |
|------------------------------------|----|-----|----|
| SCR1 | Q1 | CR8 | R5 |
| C11 | F2 | | |
| REFERENCE DESIGNATIONS NOT USED | | | |
| | | | |
| | | | |

6. FOR ASSEMBLY DRAWING SEE 9DI46, 9C368
5. ALL DIODES ARE 1N4004.
4. FOR WIRE LIST SEE 98363.
3. FOR SEPARATE BILL OF MATERIAL SEE 27-04-044979, 27-01-044963, 10-02-01-185 SSA001
2. ALL CAPACITOR VALUES ARE IN MICROFARADS.
1. ALL RESISTOR VALUES ARE IN OHMS 1/4W ±10%.

NOTES: UNLESS OTHERWISE SPECIFIED

Figure 5. Schematic (9C131-01), Main Frame Power Supply