



Professional Products

DOLBY LABORATORIES INC

London San Francisco

Model 361

DOLBY LABORATORIES
INSTRUCTION MANUAL

Dolby Laboratories Incorporated

U.S.A.: 731 Sansome Street, San Francisco, CA 94111
Tel: (415) 392-0300; telex: 34409; cable: Dolbylabs

U.K.: 346 Clapham Road, London SW9 9AP
Tel: 01 720-1111; telex: 919109; cable: Dolbylabs London

World patents pending or granted

List of Contents

| | |
|------------|--|
| Section 1 | Introduction |
| Section 2 | Controls and Connectors |
| Section 3 | Specifications |
| Section 4 | General principles |
| Section 5 | Level standardization |
| Section 6 | Applications |
| Section 7 | Installation |
| Section 8 | Operation |
| Section 9 | Interface circuit description |
| Section 10 | Cat. No. 22 Noise Reduction Module circuit description |
| Section 11 | Interface servicing |
| Section 12 | Cat. No. 22 servicing |
| Section 13 | Cat. No. 35 NRM Test Set |

SECTION 1
MODEL 361 NOISE REDUCTION SYSTEM - INTRODUCTION

Introduction

The Dolby A-Type Noise Reduction System has been designed to reduce noises commonly encountered in audio signal recording and transmission systems. These noises may take the form of rumble, hum, crosstalk, clicks, pops, buzzing, and hiss, as well as discrete frequency interference such as television synchronizing pulse crosstalk. All of these noises are reduced by the system without affecting the overall frequency response or dynamics of the signal itself.

In the particular field of magnetic tape recording, the system will reduce tape hiss and also alleviate other problems such as print-through and high-frequency modulation noise. The print-through reduction is of special significance, as it allows the long-term storage of high-quality master tapes with minimal degradation.

The system is suitable for use in any situation in which the signal is available for processing at both ends of the recording or transmission chain. The processing operations can be separated by any distance or any time duration, since once correctly adjusted, the system parameters are extremely accurate and stable. Furthermore, the system is tolerant of gain-errors in the recording or transmission channel. An incorrect level to the playback unit of ± 2 dB does not result in any perceptible alteration of the restored signal.

It should be appreciated that when recording or transmission noise is reduced, other noises masked by it naturally become more apparent. Full use of the increased dynamic range provided by the noise reduction system may therefore sometimes require a tightening of standards in the rest of the chain - i. e. in connection with noise from microphone amplifiers, mixers and monitor amplifiers, as well as noise from wholly acoustic sources such as buzzing fluorescent lights, creaking chairs, and the movement of persons in the studio. (On the other hand, it can be argued that acoustic noises, having purely natural origins, contribute to a feeling of realism and immediacy).

The Dolby 361 Series units are compact second-generation Dolby A-Type (professional) noise reduction units which are fully compatible with the A301. Designed with space and weight in mind, the units are especially useful for multi-track and portable work. The Model 361 is a single processor unit with built-in changeover facilities. This model is designed to serve one recorder track during both recording and playback (with monitoring of line-in or the unrestored tape signal during recording). The operating mode is set by pushbutton switches on the front panel. Remote facilities are also provided, enabling changeover to be controlled automatically by the record relay circuit of the tape recorder.

The circuits used are highly stable and do not require any adjustments, apart from input and output levels, which are set during installation. The noise reduction circuitry is factory-set to precise limits and contains no adjustable controls. All components are mounted in a single module which can be purchased separately. Should failure ever occur, plug-in substitution will rapidly restore operation of the system with no adjustments necessary. A removable front panel allows the input and output controls to be adjusted from the front to match the unit to any of the normal studio signal levels; the panel also provides front access to the noise reduction module.

An internal Dolby Tone oscillator is provided for establishing correct operating levels. The characteristic modulation of this tone also serves as identification for Dolby-processed tapes. All oscillators in a multi-channel installation can be controlled by a single switch.

SECTION 2
CONTROLS AND CONNECTORS

DOLBY TONE BUTTON FOR OPERATION OF INTERNAL OSCILLATOR. PROVIDES DOLBY LEVEL SIGNAL FOR IDENTIFICATION AND CALIBRATION PURPOSES.

INTERNALLY ILLUMINATED NR IN-OUT BUTTON CONTROLS NOISE REDUCTION ACTION.

INTERLOCKED ILLUMINATED BUTTONS TO CONTROL SIGNAL APPEARING AT 'to monitor' CONNECTOR ON REAR. BUTTONS HAVE NO EFFECT ON REC/PLAY MODE OF UNIT.

MULTI-TURN POTENTIOMETER ADJUSTS INPUT SENSITIVITY TO SUIT STUDIO LINE LEVEL. ADJUST USING STANDARD TEST TAPE AND METER ON UNIT.

MULTI-TURN POTENTIOMETER ADJUSTS OUTPUT LEVEL TO SUIT STUDIO LINE LEVEL WHEN PLAYING STANDARD TEST TAPE. USED IN CONJUNCTION WITH INPUT LEVEL CONTROL TO PRODUCE UNITY GAIN THROUGH MODEL 361.

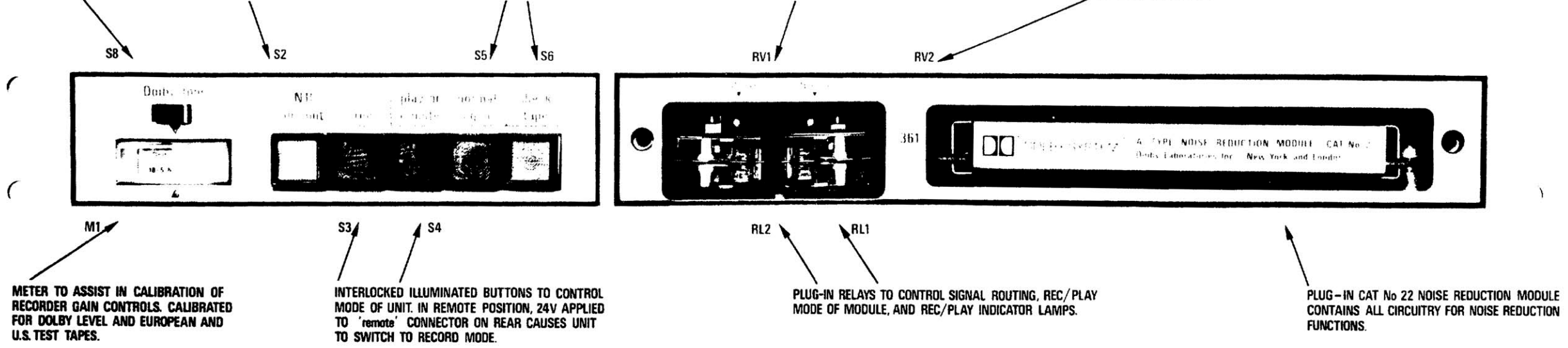

METER TO ASSIST IN CALIBRATION OF RECORDER GAIN CONTROLS. CALIBRATED FOR DOLBY LEVEL AND EUROPEAN AND U.S. TEST TAPES.

INTERLOCKED ILLUMINATED BUTTONS TO CONTROL MODE OF UNIT. IN REMOTE POSITION, 24V APPLIED TO 'remote' CONNECTOR ON REAR CAUSES UNIT TO SWITCH TO RECORD MODE.

PLUG-IN RELAYS TO CONTROL SIGNAL ROUTING, REC/PLAY MODE OF MODULE, AND REC/PLAY INDICATOR LAMPS.

PLUG-IN CAT No 22 NOISE REDUCTION MODULE CONTAINS ALL CIRCUITRY FOR NOISE REDUCTION FUNCTIONS.

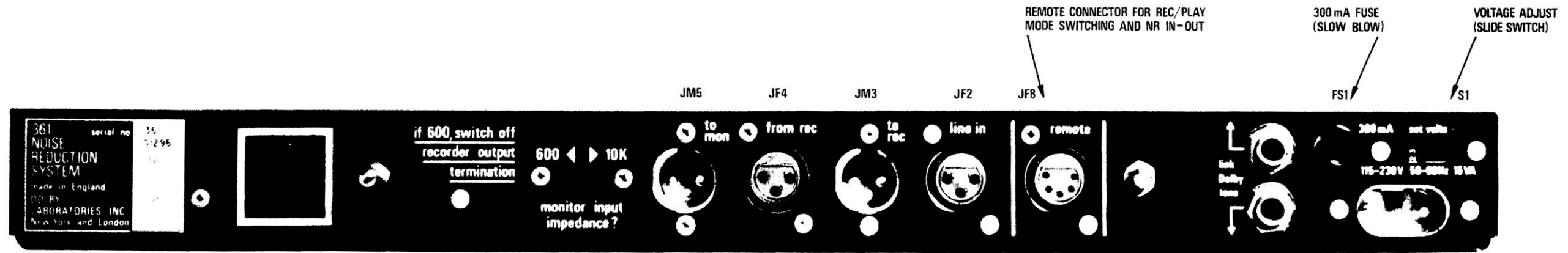

SWITCH TO SELECT CORRECT TERMINATION CONDITIONS. SET SWITCH TO CORRESPOND TO INPUT IMPEDANCE OF MONITORING SYSTEM USED. IF MONITOR HAS 600 OHM INPUT IMPEDANCE, DISCONNECT OR SWITCH OFF ANY TERMINATION WHICH MAY BE ON TAPE RECORDER OUTPUT; ALSO DISCONNECT ANY TERMINATION WHICH MAY BE CONNECTED TO RECORDER FEED OF MIXER.

JACKS LINKING DOLBY TONE FUNCTION ON SEVERAL UNITS. ALSO FOR REMOTE OPERATION OF DOLBY TONE.

POWER CONNECTOR. CENTRAL PIN IS CONNECTED TO CHASSIS.

SECTION 3
SPECIFICATIONS

Specifications - Model 361

| | |
|------------------------|--|
| Layout: | One signal processor with built-in changeover relay circuits. In addition to record-play mode changing, the unit is transferred automatically from line-in to line-out. Control either remotely (record relay of tape recorder) or by illuminated push-button switches on front panel. |
| Signal connections: | XLR input and output for line-in and line-out, and to and from recorder (cable connectors provided with unit). Rear panel switch for establishing correct termination conditions. |
| Operating controls: | Illuminated push-button switches for REC/PLAY mode, REMOTE control, noise reduction IN/OUT, and monitoring mode - NORMAL (line-in during recording, decoded signal during playback) or CHECK (encoded signal directly from tape). Push-button switch for DOLBY TONE calibration oscillator. |
| Remote control: | Five-pin XLR connector for remote control of record-play mode and line-in, line-out changeover (cable connector provided with unit). Control by external source of 24 volts dc, 6 mA (on for record mode). Alternatively, control by external single pole contact (closed for record mode). Also remote Dolby Tone. |
| Panel meter: | Level setting meter for recorder gain calibration. Calibration marks for Dolby Level (185 nWb/m, Ampex-NAB level) and DIN level (320 nWb/m). |
| Dolby Tone oscillator: | Internal oscillator provided for establishing correct operating levels on an international basis. Push-button Dolby Tone is recorded at Dolby Level (185 nWb/m) and is modulated in a characteristic way for identification. Provision for linking together Dolby Tone oscillators in multi-track installations (cable connectors provided with unit). |
| Input circuit: | Bridging transformer, 10K balanced floating. |
| Output circuit: | Transformer, 20 ohm output impedance, balanced floating; will drive any load impedance from 200 ohms upwards. |

| | |
|---|--|
| Signal levels: | Input and output levels adjusted by multi-turn potentiometers accessible from front of unit. Minimum input 350 mV for Dolby Level, 600 mV for DIN level. Maximum output level +22 dB into bridging load; +21 dBm into 600 ohms; +20 dBm into 200 ohms. |
| Overall frequency response: | ± 1 dB from 30 Hz to 20 kHz. |
| Overall total harmonic distortion: | At +8 dBm, less than 0.1% at 1 kHz; less than 0.2% from 40 Hz to 20 kHz. |
| Noise reduction: | Dolby A-Type professional characteristic, providing 10 dB of noise reduction from 30 Hz to 5 kHz, rising to 15 dB at 15 kHz. With noise reduction action switched off, unit becomes unity-gain line amplifier. |
| Overall noise level: | Record-playback, 80 dB (unweighted, 30 Hz to 20 kHz bandwidth) below Dolby Level. |
| Matching between units: | ± 1 dB at any level and any frequency, 30 Hz to 20 kHz. |
| Signal delay: | Constant with frequency, 24 μ sec per channel. Overall encode-decode process, 48 μ sec. |
| Phase error: | Less than 5° , 20-20 kHz overall encode-decode. |
| Stability: | System is highly stable - does not require routine alignment. |
| Operating temperature: | Up to 45° C. |
| Construction: | Plug-in Noise Reduction Module (Cat. No. 22) and changeover relays accessible through front panel. Fibreglass printed circuits, solid state devices throughout. |
| Finish: | Steel case, grey stoved plastic textured finish; front panel clear anodized with black characters. |
| Size: | 44 x 483 mm rack mounting ($1\frac{3}{4}$ " x 19"). Maximum projection behind mounting surface - 228 mm ($8\frac{15}{16}$ "). Maximum projection in front of mounting surface - 22 mm ($\frac{7}{8}$ "). Sixteen-track installation requires 710 mm (28") of rack space. |

Weight: 5.5 kgs (12 lbs).

Power Requirements: Units are designed for operation from centrally switched power source. Power cables provided.

100-130 V and 200-260 V, 50-60 Hz single phase, 16 VA.

SECTION 4 GENERAL PRINCIPLES

General principles

In sound recording or transmission systems the high and low audio frequencies are often pre-emphasized during recording and de-emphasized during reproduction in order to improve the signal-to-noise ratio. However, the equalization characteristic must be chosen such that even in the worst cases there are no detrimental effects; organ pedal notes or cymbal crashes must not cause distortion. Therefore the allowable boost with fixed equalization is not as great as it might be for optimum utilization of the recording medium. For example, recording an instrument such as a piano or violin does not usefully load the channel over the whole audio spectrum, and thus low and high frequency noises are particularly noticeable during reproduction.

It is clear that the situation could be improved with a more flexible equalization method. The Dolby A-type system provides a characteristic, controlled by the incoming signal, which achieves optimum loading of the recording medium under all signal conditions. During playback a complementary characteristic is applied which restores all frequency components to their correct amplitudes and phases and in the process attenuates any noise introduced during recording.

Systems which improve signal-to-noise ratios by compression in the encoding mode, followed by expansion in subsequent decoding, are known generally as companders. Such devices have a long history, and it is therefore important to discuss these conventional techniques to appreciate the significant differences between them and the Dolby system.

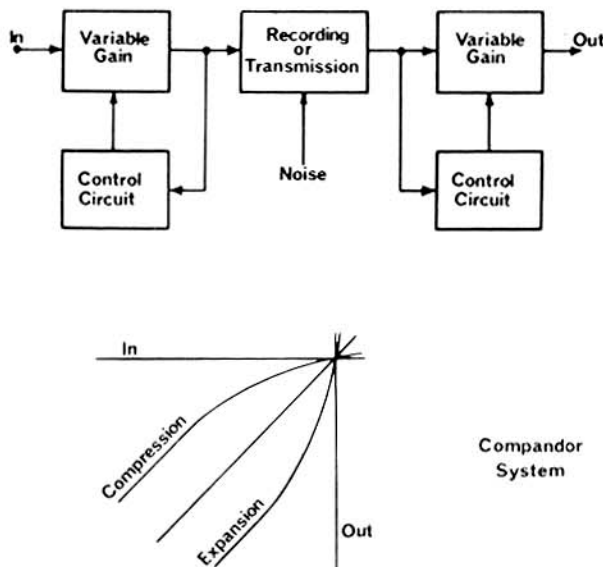

Fig. 4 1

Fig. 4.1 is a block diagram of a conventional compandor, together with its transfer characteristics. Well-known compandor difficulties - which by now are regarded as classical - include poor tracking between recording and reproducing, both statically and dynamically; high sensitivity to gain errors in recording or transmission; inadequate dynamic range (high noise level vs. high distortion); production of overshoots with transient inputs; audible modulation-product generation under dynamic conditions; distortion of low frequencies by control-signal ripple modulation; and generation of noticeable signal-modulated noise effects.

A comparison of conventional compandor performance as outlined above with the requirements for studio and broadcast applications shows that the normal compression and expansion approach is inadequate. Prior to the introduction of the Dolby type of compandor in 1966, compandors were generally found to be usable without qualification only in relatively low-grade, narrow-band applications such as telephone circuits.

In normal compression or limiting, a primary object is to modify high-level signal dynamics; it is thus unfortunately necessary to subject the signal as a whole to the hazards of passage through a variable-gain system. In applying compression techniques to the noise reduction problem, in which the objective does not include modification of signal dynamics, it is unnecessary and undesirable to operate upon high-level signal components; noise amplitude in a high-quality channel is only of the order of 0.1% of maximum signal amplitude. It is clearly preferable to generate a small correction or differential component which can be appropriately subtracted from the signal, thereby cancelling or reducing noise while leaving the larger aspects of the signal untouched.

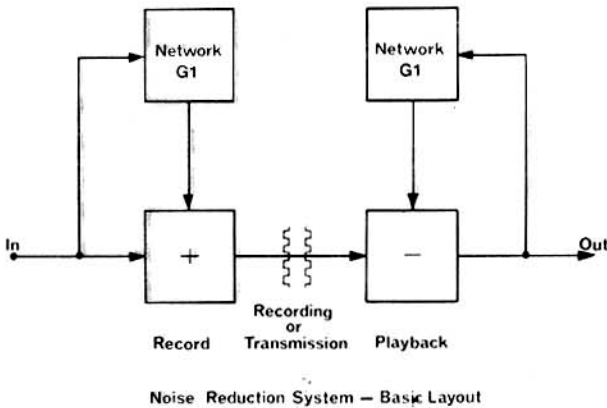

Fig. 4.2

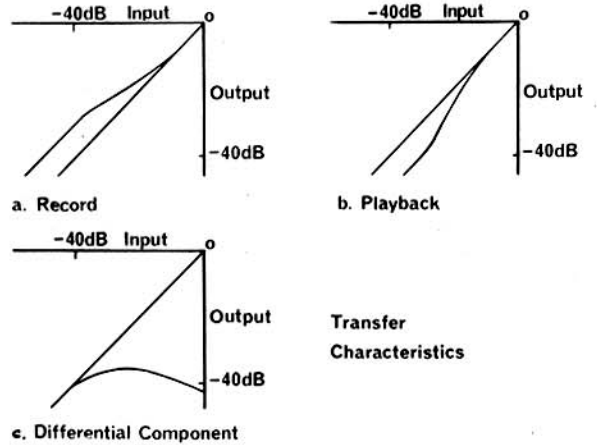

Fig. 4.3

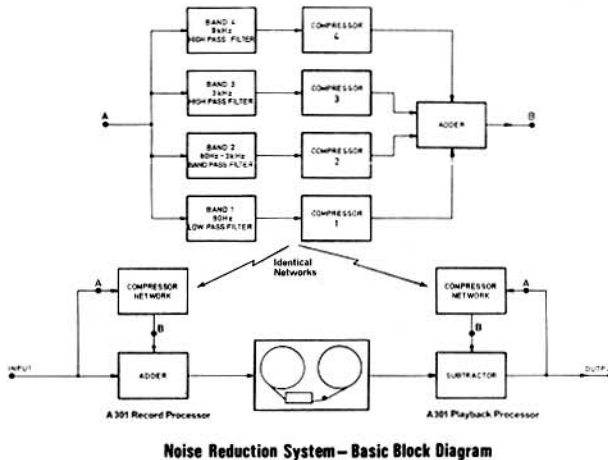

Fig. 4.4

The differential treatment of the signal in the Dolby noise reduction system is illustrated in Fig. 4.2. Incoming signals to the record unit are split into two paths. The main path treats the signal linearly. The signal in the secondary path passes through a variable attenuation network G1, the output of which is combined additively with the main signal. In playback the situation is similar, but the variable attenuation network G1 is connected in a feedback loop and its output is combined subtractively with the main signal. The basic input/output characteristic of the attenuators is given in Fig. 4.3, which also shows the encoding and decoding characteristics obtained by addition and subtraction. It is evident that the signal is modified only at low levels; by analogy with calculus, the correction signal is known as the differential component of the signal.

In practical embodiments, the Dolby method satisfies all the requirements for high-quality transmission. Overshoots are minimal (less than $1\frac{1}{2}$ dB), since the contribution of the side chain is always low even under dynamic conditions. Mis-tracking between units is a function of the attenuators, which can be designed and built to follow a standard curve to within 0.5 dB. Signal level errors between the encoding and decoding units appear at the output only as linear level changes at high and low levels, since the input/output characteristics of the playback unit are linear in these regions. Even at the level of maximum compression slope (2:1), at around -30 dB, moderate errors (about 2 dB) in recording or transmission channel gain are not noticeable on programme material.

With moderate signal level changes, the differential approach allows relatively long time constants to be used for control signal attack and decay times, and therefore modulation products are minimal. For larger signal level changes, the attack time is decreased; this is achieved by non-linear control signal smoothing circuits which also keep low-frequency distortion to a figure of less than 0.2% at 40 Hz and peak level.

In order to obtain effective noise reduction under all signal conditions, the Dolby system utilizes the psychoacoustic phenomenon of masking, which is a kind of naturally occurring noise reduction. This is combined with electronic noise reduction (compression/expansion) to provide complete overall coverage. The masking effect, extending on both sides of the signal frequency, is dependent on both the absolute and relative amplitudes of the signal and noise. Taking these facts into account, the network G1 (Fig. 4.2) is in fact four band-splitting filters, followed by four limiter circuits. In this scheme the masking effect is combined with compression and expansion in such a way that there are no audible noise modulation effects. The frequency bands are chosen with regard to the probable frequency distribution of a high-quality signal and to the types of noises likely to be encountered (Fig. 4.4).

The differential approach, together with the band-splitting technique, results in a noise reduction system which is suitable for high-quality sound transmission with excellent static and dynamic noise reduction and signal handling characteristics.

SECTION 5
LEVEL STANDARDIZATION

5.1 Basic Standardization Requirements

Correct operation of the Dolby A-type Noise Reduction System is dependent on only one basic requirement - that the signal voltage in the playback processor should be the same (within 2 dB) as that in the recording processor. In other words, the recording system should have an effective overall record-playback gain of unity. However, the requirement for signal interchangeability imposes a further requirement - that the signal levels in the noise reduction system should be related to the levels of internationally recognized standards, such as magnetic test tapes (of which the most widely used are the Ampex NAB and DIN tapes).

In order to correlate the various voltage levels and flux levels used in the complete recording or transmission chain, the concept of "Dolby Level" is employed. Dolby Level bears a fixed amplitude relationship to the noise reduction compression and expansion parameters. In 360 Series units, this level correlation is achieved in practice by a meter with a Dolby Level mark and by a special built-in Dolby Tone oscillator which generates a signal at Dolby Level. For maximum effectiveness, the Dolby Tone has been designed to be easily recognizable in order to avoid possible confusion with the multiplicity of tone signals at present in use for equalization or testing purposes. Its level has been chosen to be readily measurable on normal programme level meters in studios or broadcast stations, as well as on the meters of 360 Series units (on A301 units Dolby Level corresponds to the NAB meter mark). Since Dolby Level bears a fixed relationship to the noise reduction transfer curves, it can be further linked to the recording or transmission system parameters - i.e. line levels, flux levels, etc.

The Dolby Tone is generated by a constant-amplitude oscillator which is periodically frequency-modulated upwards with a 10% frequency change. The modulation occurs for a period in the low tens of milliseconds, which the ear interprets not as frequency modulation but more as amplitude modulation. However, since the amplitude is in fact constant, level setting meters maintain constant indications (regardless of their time constants). The A-type oscillator runs at 850 Hz and is modulated to approximately 930 Hz for 30 milliseconds every 750 milliseconds. The resulting periodic chirp-like sound is highly characteristic.

5.2 Magnetic Tape Recording

Dolby Level is linked to the flux on the tape, and is defined as 185 nWb/m. This corresponds to Ampex Operating Level (which is approximately 4.8 dB below the DIN reference level of 320 nWb/m). This flux level is used for all magnetic recording formats, e.g. magnetic film, audio tracks on video tape recorders, or magnetic sprocketed film.

5.3 Transmission Applications

Dolby Level is linked to the transmission level by the following relationships:

1. If VU meters are used, Dolby Level corresponds to 0 VU on a steady-state basis.
2. If fast risetime peak programme meters are used, Dolby Level corresponds to a level of 4 dB below the nominal 100% or peak operating level on a steady-state basis (i. e. PPM 5 for UK peak meters, +4 on the EBU meter scale, or -4 on light-beam instruments).

5.4 Optical Sound Tracks

Dolby Level is defined as 6 dB below clash (clipping) level, or 50% of full track width modulation.

5.5 Other Systems

Dolby Level can be defined by reference to the overload properties of the transmission system following the guidelines provided by the above definitions.

5.6 Adjustment of Input and Output Levels

The adjustment of signal levels is covered in detail in Section 8, Operation. A generalized description is given here to illustrate the part played by the Dolby Level calibration.

Decode or playback units are calibrated first. A tone, from a test tape or oscillator, at either 0 VU (or Ampex Operating Level - Dolby Level) or DIN (peak) level, is fed into the unit and the input level potentiometer is adjusted to give an appropriate reading on the front-panel meter on the unit (i. e. Dolby Level or DIN). The output level potentiometer is then adjusted to give unity gain through the 360 Series unit.

Following correct calibration of the decoder unit, the encoder or record unit is set up. The record gain controls on the recorder or the line sending controls on the line amplifier are adjusted to suit the usual line levels. The Dolby Tone button is pressed, and the output level control on the 360 Series unit is adjusted such that the recorded or received tone, as indicated by the previously calibrated decoder unit, is at the Dolby Level mark. The input potentiometer of the encoder unit is then adjusted to suit the incoming signal level.

After this calibration is completed, the A-type encoder and decoder units, together with the recorder or transmission line coupling them, should be treated as a fixed, unity-gain system. The decoded output is at studio or line level; for encoding, studio or line level should be fed in.

In operation, do not compensate for different types of programme material (e. g. piano) or different types of tape (e. g. high-output) by altering any of the previously adjusted record and playback gain controls in the chain; set the level actually recorded on the tape or sent to the line by adjusting the level

of the programme source (mixer output). The calibration procedure ensures that the internal characteristics of the A-type units are directly related to the transmission or recording parameters (e.g. tape flux density), and altering the gain settings to suit programme material would destroy this relationship. These precautions are essential for tape and transmission standardization. To assist in maintaining standardization in tape exchanges and inter-studio transmissions, always record or send a section of Dolby Tone at the beginning of each programme using the internal Dolby Tone oscillator.

It should be emphasized that the requirement for level standardization in using the Dolby system in no sense puts a constraint on the actual programme levels used. The programme levels themselves should be the same as those used in the absence of the Dolby system. However, with the system it may be found advantageous to devote some of the 10 dB increase in usable dynamic range to a reduction of distortion produced by the recording or transmission channel; a reduction of programme level would then be called for.

SECTION 6 APPLICATIONS

6.1 Applicability of Dolby system

Dolby A-type audio noise reduction units can be applied to any noise-introducing recording or transmission channel in which the signal is available before and after the noisy channel and in which the gain and frequency response characteristics of the channel are fixed and known. These basic considerations are discussed in Sections 1 and 4. In addition to the handling of normal music and other audio signals, the Dolby system can in principle be used for the recording or transmission of any type of analogue signal in which the ultimate method of presentation of the information is aural.

6.2 Magnetic Sound Recording

6.2.1. Mono and Stereo Tape Recording. The A-system has applications in mono or stereo recording at all tape speeds. The system will reduce tape noise, modulation noise, and crosstalk; it also reduces amplifier noise such as hum, hiss or flicker noise. Multi-generation copying is an application in which these noise reductions are particularly valuable.

6.2.2. Multi-track Tape Recording. Multi-track tapes (usually 16 and 24 tracks on 2 inch tape, 8 tracks on 1 inch) are considerably improved by the Dolby system. The mixing of tracks during reduction to a two or four track master inevitably results in an accumulation of noise on the master, following basic physical laws. For example, if ten tracks are mixed at equal level to form one new track, the signal-to-noise ratio is degraded by 10 dB. The A-system reduces the noise level of the ten-track mix to that of a single track recorded without noise reduction; an improvement of this magnitude could otherwise be achieved only by running the tape at ten times the speed or by increasing the track widths by a factor of ten (for example, resulting in a tape width of 20 inches).

6.2.3. Disc Cutting. To take full advantage of the noise reduction used in the production of the master tape, Dolby-encoded tapes should be sent for disc mastering. Each channel in the disc cutter is then decoded via Dolby A-type noise reduction units. Similarly, where copies of master tapes are sent abroad for processing by licensees, A-type encoding should preferably be used in order to maintain optimum quality (see Dolby international user list).

6.2.4. Tape Duplication. The benefits of noise reduction can be applied to all stages of a duplicating chain. With Dolby B-type (consumer) encoding on open reel, cassette, or cartridge, the noise from a single non-encoded master tape generation is audible on the resultant duplicate. It is therefore preferable that all tapes used in the duplicating process should be noise-reduced.

6.2.5. Archive Recording. Storage of magnetic tapes for archival purposes often results in magnetic printing from layer to layer in the reel, producing pre- and post-echoes. If the original tape has been encoded by Dolby A-type noise reduction units a long term 10 dB reduction in print-through is achieved. While a reduction of print-through cannot be obtained on existing conventionally recorded tapes, further print can effectively be arrested by re-recording of the material through A-type units.

6.2.6. Sprocketed Magnetic Film. The Dolby system can be of significant assistance in the motion picture and television industries for sound recording on 35 mm or 16 mm sprocketed magnetic film. The use of noise reduction is especially valuable wherever the final sound track may be built up from several synchronized recordings or where multiple generation dubbing techniques may be used.

6.2.7. Video Tape Recorders. The quality of the audio track on both quadruplex and helical scan video tape recorders is usually inferior to that of professional audio recorders. The poor quality is due to a combination of narrow tracks, thin oxides, a disadvantageous magnetic orientation of oxide particles (which for quadruplex recorders are aligned in the direction of the transverse video tracks rather than that of the audio tracks), and various crosstalk and spurious signal problems, such as from the control track, video tracks, and capstan drive motor. The A-system can improve the main audio track nearly to studio quality; this provides not only recording of superior sound quality but in addition the capability of utilizing electronic editing and transfer or dubbing techniques without excessive noise build-up.

The quality of the cue tracks (in particular on quadruplex machines) is significantly inferior to the main audio track, since the track is even narrower. In the case of quadruplex machines, break-through of control track pulses and tone occurs. There are occasions when it is desirable to raise the quality of the cue track to allow a second audio channel to be recorded - for example in countries where two languages exist. The Dolby A-system is capable of upgrading the cue track to a satisfactory standard for full broadcast use.

6.3 Transmission Applications

6.3.1. Landlines. Lines between studios and transmitters, or between distribution centres, are still often coaxial or twisted pairs. Such lines are subject to a variety of interferences ranging from cross-talk and telephone dialling pulses to low frequency noise which can be either hum or noises introduced by earth or sea movements. Adjacent circuits carrying video signals may contribute television line-frequency interference. Landlines often suffer from considerable high frequency attenuation, and the degree of high frequency equalization which then has to be applied may result in unacceptable high frequency noise. The Dolby system is of great value in alleviating these line noise problems.

6.3.2. Microwave Links. Broadcast signals are often sent from station to station through some form of microwave system. This may take the form of a number of probably adjacent 3 kHz bandwidth channels multiplexed onto a carrier. At the receiving end of the chain the 3 kHz channels are demodulated and re-assembled. Any over-modulation of the channels can cause distortion products to be generated in adjacent channels; hence signal overshoots must be minimal. The Dolby A-type noise reduction technique avoids overshoot problems and allows transmission of all types of programme. The noise reduction action also removes low-level carrier interference signals which may occur in this type of transmission.

6.3.3. Other Transmission Methods. The A-type system is generally suitable for use with any communication link with fixed gain and frequency response characteristics. However, for correct operation the signal entering the decode processor should be identical (within normal operating tolerances) to that leaving the encode processor. The signals should also be in unequalized (flat) form.

6.4 Motion Picture Industry

6.4.1. Location Recording. Since Dolby A-type noise reduction units have application throughout the motion picture industry, from the location recording to the final print in the cinema, it is preferable if a sound recording is A-type encoded from the beginning. On location, camera noise and other naturally occurring sounds will often dominate the tape noise. But there are many instances when this is not so, and the use of noise reduction at this early stage increases the flexibility in subsequent signal processing without the hazard of noise build-up.

6.4.2. Transfer and Dubbing. The motion picture industry has traditionally used the technique of multiple dubbing to assemble the final master (full-coat, triple or M.E.D.) recording from a variety of sources (dubbing units), rather than the music recording industry's method of parallel recording on multi-track machines. Clearly noise build-up is a problem which can be alleviated by use of the Dolby technique.

6.4.3. Release Prints. Historically, the sound quality of the cinema itself - the final link in the chain - has lagged behind the rest of the audio entertainment industry. Early methods of recording and reproduction were limited, and cinemas were designed to use a high frequency roll-off, known as the Academy roll-off, to reduce the effects of wideband and impulsive noise. The loss is severe - about 15 dB at 8 kHz which, when added to the high frequency attenuation in the speaker-screen combination, causes dialogue and music to be dull and indistinct. To improve intelligibility it has become common studio practice to boost middle and high frequencies during dubbing, causing further distortion due to the limited modulation capabilities of the film. The Dolby A-type system provides the way out of the dilemma, making it possible to produce wide-range optical sound, since the system reduces background noise without impairing high frequency response. Special A-type units are available for installation in cinemas, enabling the new Dolby encoded optical or magnetic tracks to be replayed, yet retaining the switched option of standard Academy responses for non-encoded material. The units can be used with combined or separate optical or magnetic tracks.

6.5 Sound Delay and Echo Systems

6.5.1. Tape Delay. Popular tape delays use either an endless tape loop or a magnetic disc; both systems use a master recording head and several playback heads. Delay units are used to increase intelligibility in large reverberant buildings, to equalize time-differences between vision channels transmitted via satellite and their associated audio channels transmitted via

cable, or to create special sound effects. Since magnetic tape is usually the recording medium, noise is a problem which can be alleviated through the use of the A-type noise reduction system.

6.5.2. Electronic Delay. Various methods are being used to produce electronic delays, including shift registers and sample, storage and read circuits. For economic reasons the noise performance is often inadequate for the most demanding applications, and in general the noise spectra is obtrusive since it is not white. In such instances the signal can be noise reduction encoded prior to the delay unit and decoded at the output, yielding a significant improvement in signal-to-noise ratio.

6.5.3. Reverberation systems. Echo chambers or reverberant plates are often noise limited. Dolby A-type noise reduction units can be placed around the echo chain, resulting in a significant improvement in signal-to-noise ratio. Unfortunately, such applications are not as straightforward as they might appear, since due to dispersion the signal at the decoder is not identical to that leaving the encoder. Thus a comparison of the signal with and without noise reduction will reveal differences. The apparent reverberation time will be decreased, but this can be compensated by readjustment of the plate time or room damping materials.

6.6 Digital Applications

Digital techniques are becoming more common as the size and cost of complex semiconductor logic arrays are reduced. Digital techniques for delay purposes have already been discussed (Subsection 6.5.2.). Another digital application is the use of pulse code modulation (PCM) for signal transmission. To describe an audio signal in digital form needs a given number of bits (level samples) occurring at a given sampling rate, producing a serial data rate in the order of 500 kilobits per second. To transmit this information requires a wide bandwidth; or in recording terms either a multiplicity of tracks or a high head-to-tape speed. The data rate can be reduced if one of the required performance parameters is relaxed, such as signal to noise ratio; incorporation of the analogue A-type noise reduction system into existing or new digital designs can save two bits to give a useful reduction in bit rate for a given ratio. The economic saving of two bits can sometimes be greater than the cost of the A-type processors. The processors should be used before the input to the digital encoder and after the output of the digital decoder.

6.7 Electronic Music

It is not necessary that the programme being encoded consist of naturally occurring sounds. The A-system is equally effective when processing the signals which are often found in electronic music composition. Furthermore, because of the specialized techniques (such as multiple dubbing and the mixing of many pre-recorded sources) employed in these compositions, noise reduction is of particular value in preventing excessive noise build-up.

SECTION 7
INSTALLATION



DOLBY LABORATORIES INC

A-TYPE NOISE REDUCTION SYSTEM

INSTALLATION INSTRUCTIONS

MODEL 361

One channel record-playback (automatic changeover)

NOTE: CHECK VOLTAGE SELECTOR BEFORE APPLYING POWER

1. Unpack Model 361 units and check for damage. Remove top covers of units and check interiors. Remove front cover-plates and check relays.
2. Mount units in rack.
3. Set voltage selector switches (115-230 v) appropriately.
4. Connect power cables. If power plugs on cables are changed for another type, the following wiring convention should be observed (for cables supplied with units).

| | | |
|-------------------|---------------------------|---------------------|
| U. S. style | Power: L, black; N, white | Earth: green |
| Continental style | Power: L, brown; N, blue | Earth: yellow/green |
5. Connect record/play remote control circuits to recorder electronics. The two remote control relays in the Model 361 are controlled by a low current 24 v reed relay (6 mA dc - energized in record mode).

By means of a two conductor cable and the five-pin XLR cable connector provided, connect the reed relay coil (pins 2 and 3 of five-pin connector) directly across the record relay coil of the tape recorder if the record circuits are operated by 24 v dc. If a higher dc voltage is employed in the recorder, a voltage dropping resistor can be used in series (for 40 v dc circuits, use 2.7k, 1/2 watt; for 110 v dc circuits, use 15k, 1 watt).

Another method of operating the reed relay coil utilizes the internal 24 v dc supply of the Model 361, which is brought out to the five-pin XLR connector (pin 1 is earth, pin 4 is 24 v). Using a jumper, connect pins 3 and 4 together on the five-pin XLR cable connector. The coil is energized (record mode) by making a connection between pins 1 and 2. These pins may thus be taken to any convenient single-pole switch or relay contact.

6. Connect signal cables to Model 361 units using three-pin XLR cable connectors provided. Prepare cables from mixing console; cables to recorder; cables from recorder; cables to monitor facilities. In all of the three-pin XLR signal connectors, pin 1 is earth and pins 2 and 3 are the balanced-floating winding of the input or output transformer, with pin 2 as the "low" side and pin 3 as the "high" side for standardized phasing. For unbalanced operation, pin 2 should be connected to earth; pin 3 is signal.

7. Set MONITOR IMPEDANCE switches (600 ohms or 10k) appropriately; if 600 ohms, switch off output terminations on recorder. No termination resistors need to be added anywhere in the installation; all termination conditions are established correctly by the Model 361 switches and the recorder output termination switches according to the above procedure.
8. Link together Dolby Tone circuits of all Model 361 units using a two conductor cable and the jack plugs provided. The Dolby Tone oscillator and calibration circuitry in the Model 361 are activated by connecting the center pin of the jack plug to earth. Pressing the Dolby Tone button on any linked Model 361 unit connects this pin to earth. The Dolby Tone may be activated remotely (at the mixing console, for example) simply by extending the jack plug links; connect a single pole normally-open push button to the end of the remote link.
9. Noise Reduction IN-OUT function may be controlled remotely using pins 5 and 1 of the five-pin XLR connector. These two pins should be joined, using a remote switch, for NR OUT. Because of the possibility of earth (hum) loops, pin 1 should not be connected to any remote earth point. A separate circuit and switch should be used for each channel. The remote switches do not replace the front panel switches but are connected in parallel; therefore for remote operation the front panel switches must be depressed (NR IN) Note that the indicator lamps in the Model 361 units will remain illuminated even when the remote switches are in the NR OUT position.

If illuminated remote indication of NR IN-OUT mode is desired, use two-pole remote switches with suitable lamps connected via the second pole. The 24 v supply in each Model 361 unit (pins 1 and 4 of the five-pin XLR) may be used (max current 100 mA). A separate earth line (from pin 1) must be used for each lamp circuit in order to avoid hum loops in the NR OUT position.
10. Refer to Model 361 Operating Instructions for calibration and operating procedures.

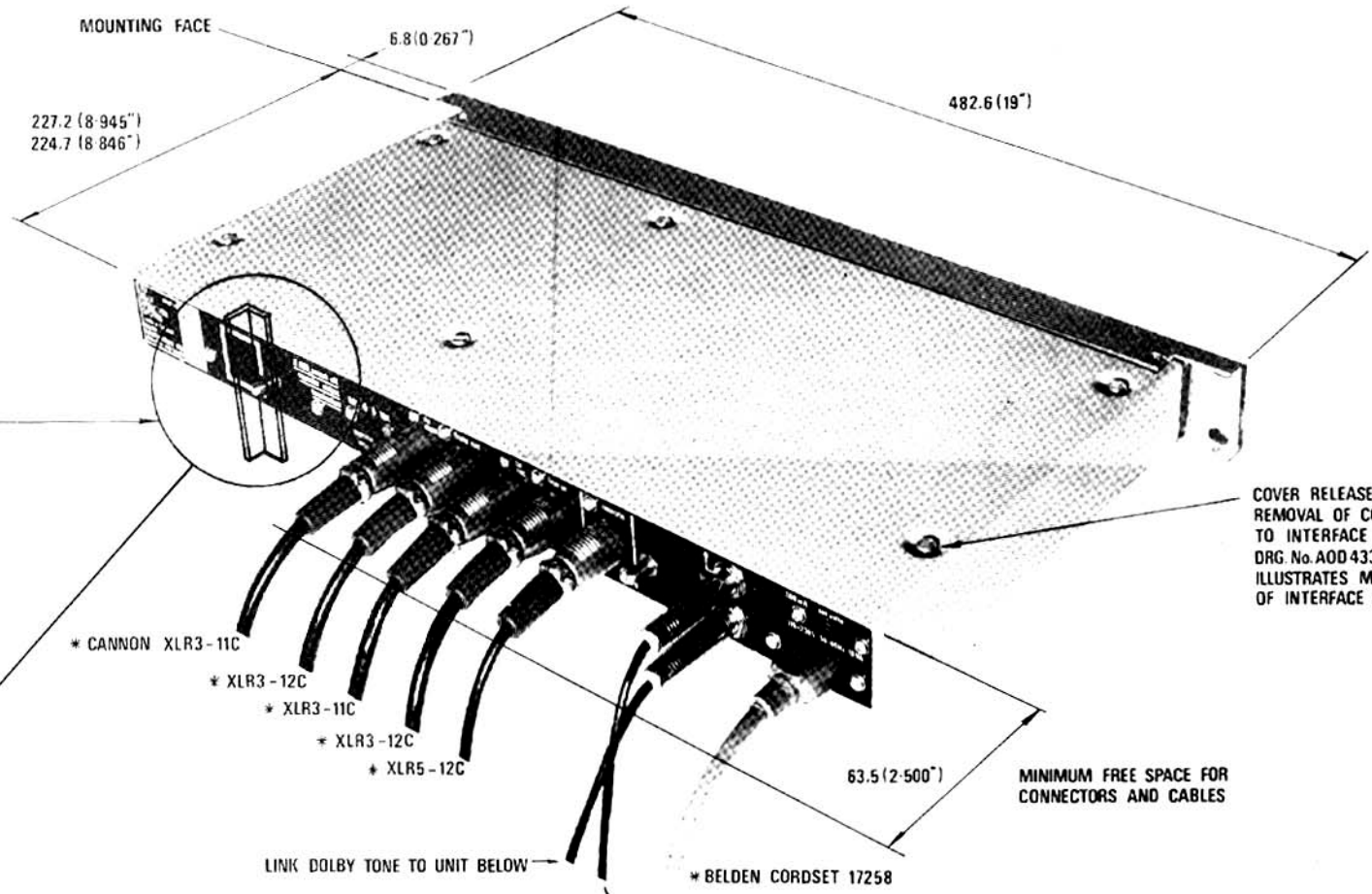

IT IS SUGGESTED THAT FIXINGS FOR SUPPORTS ARE ADJUSTABLE TO ALLOW FOR POSSIBLE TOLERANCE BUILD-UP ON REAR DOWEL CENTRES

COVER RELEASE SCREWS (6)
REMOVAL OF COVER GIVES ACCESS TO INTERFACE CHASSIS.
DRG No. AOD 433 "GENERAL SERVICING ACCESS" ILLUSTRATES METHOD OF THE REMOVAL OF INTERFACE CHASSIS FOR SERVICING

* ALL CABLE CONNECTORS ARE SUPPLIED WITH EACH UNIT

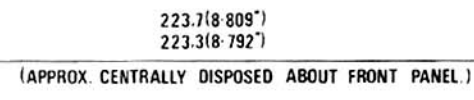
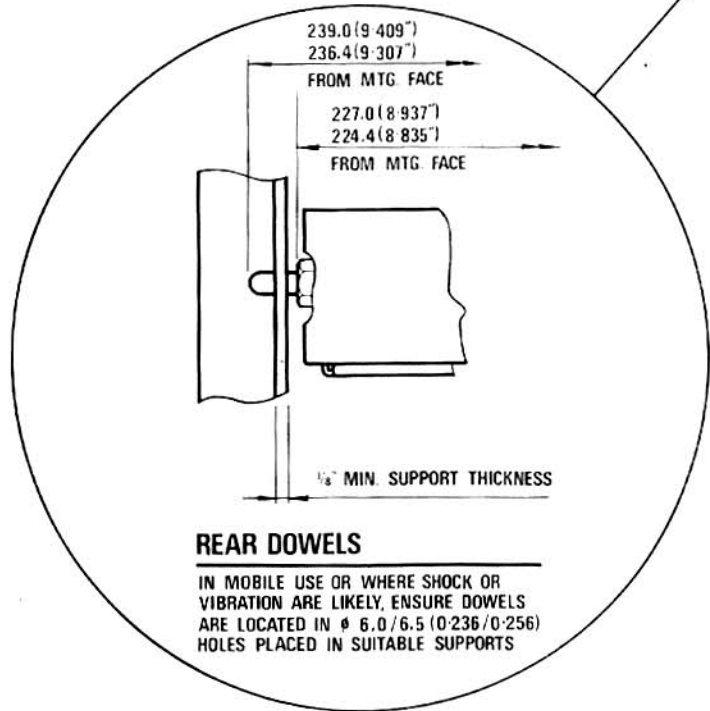

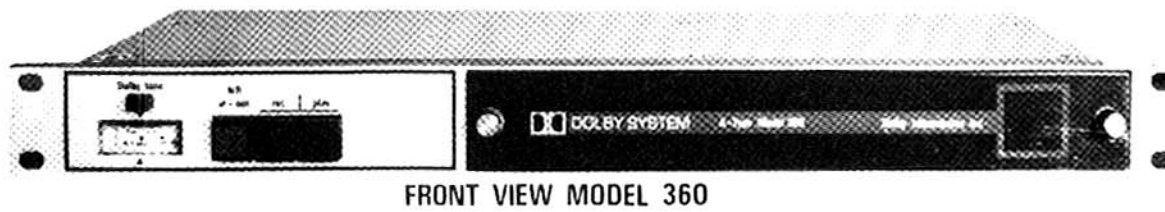
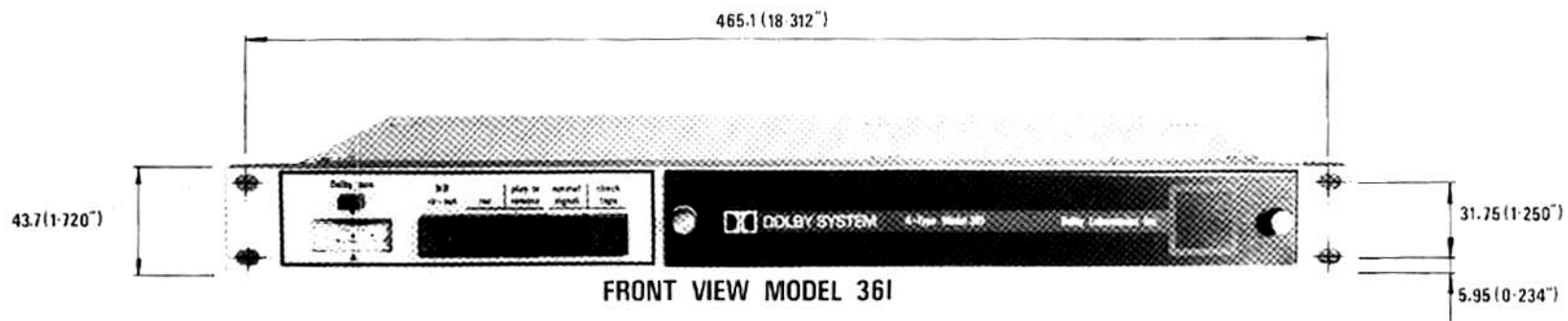
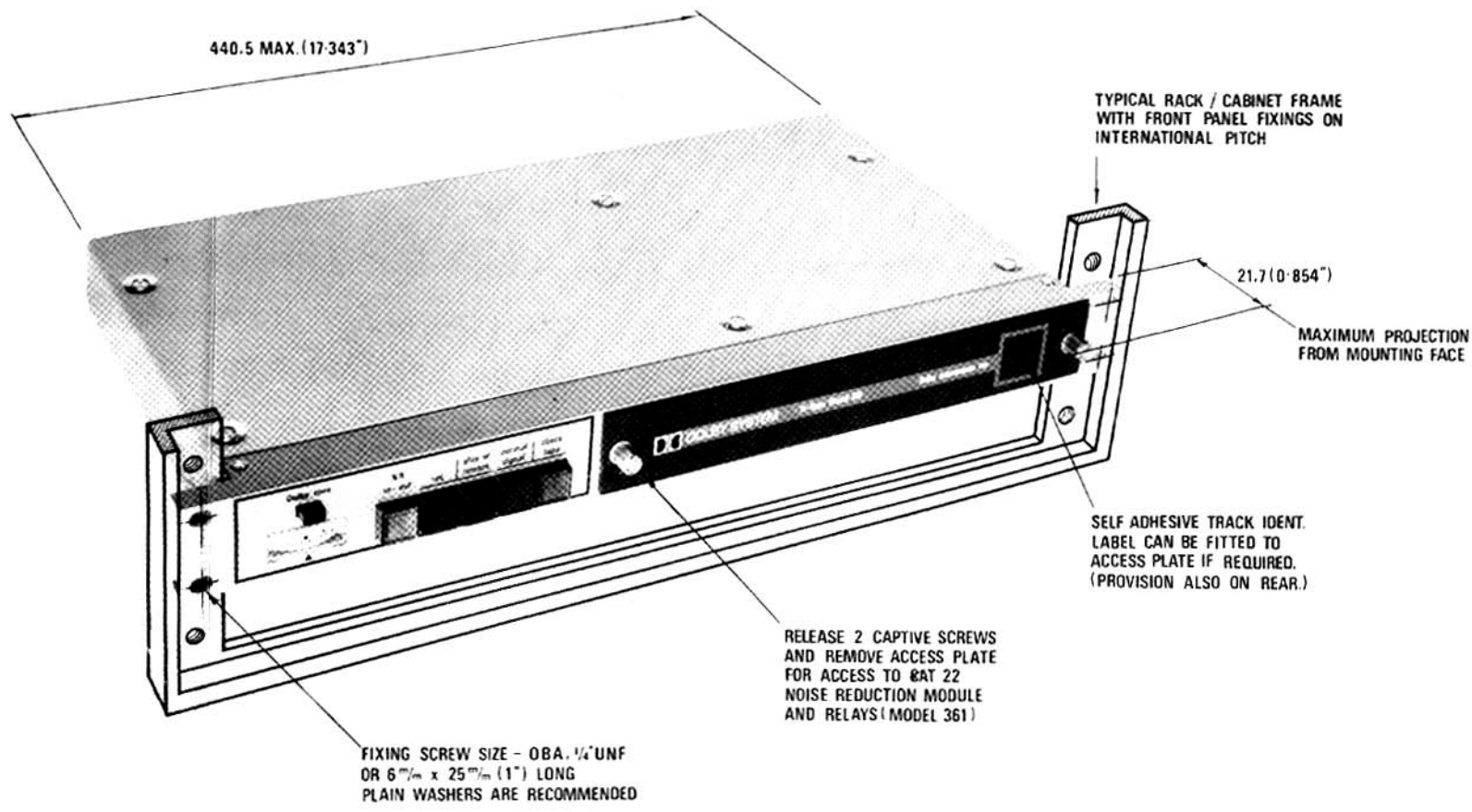

INSTALLATION INFORMATION — 330 and 360 Series
 All dimensions in millimetres auxiliary dimensions in inches Drg. No. A0D 495

**SECTION 8
OPERATION**

DOLBY MODEL 361

OPERATING INSTRUCTIONS

See separate instructions for Model M16 and Model M16H

Revised Version - March 1975

8.1 Introduction

These instructions supersede all previous 361 instructions. The new instructions allow for a greater variety of operating conditions, including those of the pre-1975 instructions. In particular, the new instructions take account of elevated level operation and the use of non-standard (user-selected) magnetic flux levels for Dolby Level.

The pre-1975 recommendation of Dolby Laboratories was a strict adherence to 185 nWb/m for A-Type Dolby Level in magnetic recording. The intention was to promote tape interchangeability without any theoretical need for Dolby Tone on each tape or for recorder adjustment in order to match any tape being played. With the new high output tapes the previous procedures have not proved to be practicable in some cases in which studios have used various elevated level test tapes and recording procedures. Confusion and incorrect operation of the Dolby units have sometimes been the result.

These new instructions recognize the existing situation and include procedures for operation under the following conditions:

- A. Standard recording level with standard Dolby Level (185 nWb/m).
- B. Elevated recording level with standard Dolby Level (185 nWb/m).
- C. Elevated recording level with elevated Dolby Level (user-selected).

Condition A is the one applying in pre-1975 Dolby instructions. Many studios continue to operate on this standard, choosing to use standard level recording tapes (e.g. for minimum print-through) or choosing to take some of the headroom of high output tapes in the form of reduced distortion. These considerations are particularly relevant in classical music, in which long-term storage quality and standardization are important. Many popular music studios also continue to operate under standard condition A, primarily in Europe.

When studios change to high output tapes, they often change the operation of their Dolby units to condition C, either intentionally or inadvertently: it is the latter which causes problems because such studios often do not record Dolby Tone on the beginning of the tape. (A short recording of Dolby Tone will always ensure correct decoding or overdubbing at any time by any studio, regardless of the flux level used for Dolby Level). Since many studios, especially in the Los Angeles area, are already effectively operating in accordance with condition C, a recommended alignment procedure is included in these instructions.

A procedure for condition B is also included, as there are some studios which up to now have been operating in accordance with condition A but who wish to use elevated level on high output tape while still retaining Dolby Level at the 185 nWb/m standard. Some studios are already operating in this way (e. g. some in London).

For initial calibration, check through the reasons given for operation under the three different conditions below (A, B, C). choose the condition that matches your situation best; use it for initial calibration and ignore the others. For normal operation, section 8.3 applies regardless of the initial calibration method used.

Note that the actual noise reduction operation of the Dolby system is the same regardless of the calibration procedure used. Consistent use of any of the following procedures will produce correct results. However, various steps of the different procedures should not be mixed together.

Before proceeding to the calibration instructions below, check that the installation has been carried out according to 'Installation Instructions: Model 361'. In particular, check that all of the LINK DOLBY TONE connectors on the backs of the 361 units are wired. This is very important. Also check that all of the 361 and recorder termination switches are set correctly.

8.2 361 Initial Calibration: CONDITION A

Condition A: Standard recording level with standard Dolby Level (185 nWb/m).

Some of the following are reasons for operation under condition A:

- a) You record classical music or other demanding material at standard recording levels. Noise is not particularly a problem and it is important, by appropriate choice of tape, to minimize distortion, print-through and high frequency compression.
- b) The original tapes of the material you record must be stored on a long term basis. Therefore, standard level recording tapes must be used in order to minimize print-through and ensure long-term stability of the recording. Dolby Level standardization for ease of auditioning and collating material is also important.
- c) You are a new Dolby user and have checked that other studios with which you will be exchanging tapes operate on this standard.
- d) Not necessarily any of the above, but you are already operating under these conditions, having followed the original recommendations, and you wish to continue on the same standard for the sake of convenience.

The pre-1975 Dolby 361 calibration procedures can be used for operation under condition A. Alternatively, the following new procedure is a particularly convenient one, in that it separates tape recorder calibration from Dolby 361 calibration; the end result is still condition A.

Procedure A

For standard recording level with standard Dolby Level (185 nWb/m).

1. Disconnect the 361 power (which de-energizes the relays) and press the 361 CHECK buttons to bypass the units both to and from the recorder.

Note: Bypassing of the 361 units is not normally required during routine alignment of the tape recorder; the signals to and from the recorder can pass unmodified through the 361 units (with the NR switches set to the OUT or released position). Nevertheless, during initial installation of the Dolby 361 units the bypassing exercise is useful for familiarization purposes; the bypass mode can be used in the event of Cat. No. 22 Noise Reduction Module failure.

2. Adjust both play and record aspects of the tape recorder, including its line level interfacing with the console. Use an Ampex (185 nWb/m) test tape. European equivalent is a DIN 320 nWb/m test tape. The input and output line voltages of the recorder must be the same (also, recorder and console meter readings should match or at least have a known relationship: correct the meter calibrations if necessary). If the machine has separate sync level controls, they should be set to match play level.

Note: As an alternative to the tapes mentioned above, Dolby Level Reference Tapes are now available from Dolby Laboratories. The tapes are available in $\frac{1}{2}$ ", 1" and 2" versions - Cat. No. 72, 73 and 74 - and contain 5, 8 and 10 minutes, respectively, of Dolby Tone at standard Dolby Level, 185 nWb/m.

3. Restore power to the 361 units and press the NORMAL monitor buttons to put the 361 units back into the circuit. Press the 361 REMOTE (play) buttons. Set the NR switches to the OUT (released) position.
4. Play the test tape used during recorder calibration (step 2 above) again and check the recorder line output meter reading. The playback level (and sync level) controls on the recorder should be trimmed, if necessary, so that the recorder line output level is the same as in step 2 above.

Note: No trimming should be necessary with bridging (10 kohm) tape return inputs on the console. With '600 ohm' tape return inputs, no trimming should be necessary if the actual impedance is reasonably close to 600 ohms (adjust impedance with extra resistors if necessary).

5. Continue playing the test tape and adjust the INPUT controls on the 361 units (remove front cover-plates) until the 361 meters read on the DOLBY LEVEL dot (with Ampex test tape) or read on the DIN dot (with DIN test tape, which is 4.8 dB higher). View meters from front rather than radially for DIN reading; i. e. do not allow for parallax.
6. Remove the test tape. Use blank tape and put the recorder into record mode. Ensure that the recorder output switches are set to the 'playback' (from tape) position. Press the 361 REC buttons if the units are not wired for remote mode control by the recorder.
7. Press the 361 CHECK buttons.
8. Feed test tone at any convenient level from the console to the recorder (through the 361 units).
9. Check that the 361 NR buttons are in the OUT (released) position.

While recording the test tone, adjust the OUTPUT controls on the 361 units until the recorder meters and/or the tape return meters on the console give the same readings as would be obtained without the 361 units. This completes the alignment.

10. As a check on the alignment, continue recording and press the DOLBY TONE button on one 361 unit to record Dolby Tone (note: for correct routine operation of the Dolby system it is essential that all of the LINK DOLBY TONE connectors should be wired). The alignment is satisfactory if the 361 meters read within the DOLBY LEVEL dot while the DOLBY TONE button is depressed. This is independent of whether an Ampex or DIN test tape has been used during recorder calibration.

Note: If the 361 meter readings are outside the DOLBY LEVEL dot (e. g. due to '600 ohm' impedance discrepancies in the console and/or the tape recorder, as well as tolerances in the 361 units), then the recorder input level controls should be trimmed.

Simplified Procedure

The above procedure (steps 1-10) results in optimum consistency of meter readings throughout the whole audio chain (console, 361, recorder, 361, console), especially with consoles having 600 ohm tape return inputs. However, a simpler and often more convenient variation also gives good results, especially with consoles having bridging tape return inputs. The simplified procedure below does not require tone from the console for 361 alignment.

Procedure

Carry out all steps up to and including step 6 above. Then replace steps 7 - 10 with the following steps:

- 7a. While recording, press the DOLBY TONE button on one 361 unit (note: for correct routine operation of the Dolby system it is essential that all of the LINK DOLBY TONE connectors should be wired).
- 8a. Continue recording Dolby Tone and adjust the OUTPUT controls on the 361 units until the 361 meters read on the DOLBY LEVEL dot. This is independent of whether an Ampex or DIN test tape has been used during recorder calibration. Alignment is now complete.

After the calibration procedure A above has been carried out, it is normally unnecessary to make any further adjustments on the Dolby 361 units. Level variations due to changes in tape sensitivity should be compensated by adjusting the input level controls on the tape recorder.

8.2 361 Initial Calibration: CONDITION B

Condition B: Elevated recording level with standard Dolby Level (185 nWb/m).

Some of the following are reasons for operation under condition B:

- a) You move your Dolby 361 units around and patch them into a particular session only when required. On non-Dolby sessions, your recorders are set up for elevated level operation on high output tape. When patching in your Dolby units you want to continue operating at elevated level without having to recalibrate anything.
- b) You use the Dolby system all the time but you feel that you would like to improve the signal-to-noise ratio still further by recording at elevated level on high output tape. At the same time you want to retain Dolby Level at the standard 185 nWb/m for compatibility with standard level tapes you have already recorded (i. e. under condition A above). Print-through is not a serious problem with the type of material you record.
- c) Some other studios in your area (e. g. London) are recording in this way and you would not only like your Dolby Level but your recorded signal levels to be compatible for overdubbing purposes.

The pre-1975 Dolby 361 calibration procedures took account of the above conditions only to the extent that increasing the output from the console was recommended for elevating the recording level. Such an increase in console level is not always possible or practicable. The following improved procedure is therefore recommended.

Procedure B

For elevated recording level with standard Dolby Level (185 nWb/m).

1. Disconnect the 361 power (which de-energizes the relays) and press the 361 CHECK buttons to bypass the units both to and from the recorder.

Note: Bypassing of the 361 units is not normally required during routine alignment of the tape recorder; the signals to and from the recorder can pass unmodified through the 361 units (with the NR switches set to the OUT or released position). Nevertheless, during initial installation of the Dolby 361 units the bypassing exercise is useful for familiarization purposes; the bypass mode can be used in the event of Cat. 22 Noise Reduction Module failure.

2. Adjust both play and record aspects of the tape recorder for operation at the desired elevated recording level, including line level interfacing of the recorder with the console. Any test tape can be used for this step. The input and output line voltages of the recorder must be the same (also, recorder and console meter readings must match or at least have a known relationship; correct the meter calibrations if necessary). If the machine has separate sync level controls, they should be set to match play level.
3. Restore power to the 361 units and press the NORMAL monitor buttons to put the 361 units back into the circuit. Press the 361 REMOTE (play) buttons. Set the NR switches to the OUT (released) position.
4. Play the test tape used during recorder calibration (step 2 above) again and check the recorder line output meter reading. The playback level (and sync level) controls on the recorder should be trimmed, if necessary, so that the recorder line output level is the same as in step 2 above.

Note: No trimming should be necessary with bridging (10 kohm) tape return inputs on the console. With '600 ohm' tape return inputs, no trimming should be necessary if the actual impedance is reasonably close to 600 ohms (adjust impedance with extra resistors if necessary).

5. Next play an Ampex (185 nWb/m) test tape. Because of the elevated level settings, the recorder meters will read low. European equivalent is to play a DIN (320 nWb/m) test tape.

Note: As an alternative to the tapes mentioned above, Dolby Level Reference Tapes are now available from Dolby Laboratories. The tapes are available in $\frac{1}{2}$ ", 1" and 2" versions - Cat. No. 72, 73 and 74 - and contain 5, 8 and 10 minutes, respectively, of Dolby Tone at standard Dolby Level, 185 nWb/m.

6. While playing the test tape, adjust the INPUT controls on the 361 units (remove front-cover plates) until the 361 meters read on the DOLBY LEVEL dot (with Ampex test tape) or read on the DIN dot (with DIN test tape, 4.8 dB higher). View meters from front rather than radially for DIN reading; i.e. do not allow for parallax.
7. Remove the test tape. Use blank tape and put the recorder into record mode. Ensure that the recorder output switches are set to the 'playback' (from tape) position. Press the 361 REC buttons if the units are not wired for remote mode control by the recorder.
8. Press the 361 CHECK buttons.
9. Feed test tone at any convenient level from the console to the recorder (through the 361 units).

10. Check that the 361 NR buttons are in the OUT (released) position. While recording the test tone, adjust the OUTPUT controls on the 361 units until the recorder meters and/or the tape return meters on the console give the same readings as would be obtained without the 361 units. This completes the alignment.
11. As a check on the alignment, continue recording and press the DOLBY TONE button on one 361 unit to record Dolby Tone (note: for correct routine operation of the Dolby system it is essential that all of the LINK DOLBY TONE connectors should be wired). The alignment is satisfactory if the 361 meters read within the DOLBY LEVEL dot while the DOLBY TONE button is depressed. This is independent of whether an Ampex or DIN test tape has been used during recorder calibration.

Note: If the 361 meter readings are outside the DOLBY LEVEL dot (e.g. due to '600 ohm' impedance discrepancies in the console and/or the tape recorder, as well as tolerances in the 361 units) then the recorder input level controls should be trimmed.

Simplified Procedure

The above procedure (steps 1 - 11) results in optimum consistency of meter readings throughout the whole audio chain (console, 361, recorder, 361, console), especially with consoles having 600 ohm tape return inputs. However, a simpler and often more convenient variation also gives good results, especially with consoles having bridging tape return inputs. The simplified procedure below does not require tone from the console for 361 alignment.

Procedure

Carry out all steps up to and including step 7 above. Then replace steps 8 - 11 with the following steps:

- 8a. While recording, press the DOLBY TONE button on one 361 unit (note: for correct routine operation of the Dolby system it is essential that all of the LINK DOLBY TONE connectors should be wired).
 - 9a. Continue recording Dolby Tone and adjust the OUTPUT controls on the 361 units until the 361 meters read on the DOLBY LEVEL dot. This is independent of whether an Ampex or DIN test tape has been used during recorder calibration. Alignment is now complete.
-

After the calibration procedure B above has been carried out, it is normally unnecessary to make any further adjustments on the Dolby 361 units. Level variations due to changes in tape sensitivity should be compensated by adjusting the input level controls on the tape recorder. However, if the type of tape is markedly different (allowing operation at a different elevated level - e.g. + 4 dB instead of + 2 dB), then the complete procedure B above must be carried out again.

Operating note: Under operating condition B, an elevated signal level passes through the processing portions of the 361 units (but the line output circuits handle normal signal levels). The elevated signal level can be handled adequately by the 361 circuits since the internal overload point is 20 dB above Dolby Level. This is above the saturation point of high output tape; the 361 units therefore do not limit the signal levels which can be used.

Under this operating condition, the 361 meters will read high on program material and may frequently deflect full scale. No harm is done since the meter circuits include overload protection.

8.2 361 Initial Calibration: CONDITION C

Condition C: Elevated recording level with elevated Dolby Level (user-selected).

Some of the following are reasons for operation under condition C:

- a) You do not use a standard Ampex calibration tape (185 nWb/m) but instead use one of the other recently available test tapes.
- b) You move your Dolby units around and patch them into a particular session only when required. On non-Dolby sessions, your recorders are set up for elevated level operation on high output tape. When patching in your Dolby units you want to continue operating at elevated level without having to recalibrate anything.
- c) Most of the studios with which you exchange tapes are operating with an elevated Dolby Level (e.g. 3 dB above Ampex level) on high output tape and you wish to be compatible with them.
- d) Some of your clients have their own ideas about recording levels and types of tape to be used. You want to accommodate them during their sessions simply by readjusting your recorder, leaving the Dolby 361 settings alone.

Non-standard Dolby Level operation (condition C) was not considered at all in the pre-1975 Dolby calibration procedures. Nevertheless, such operation is a reality in some studios (e.g. many in the Los Angeles area). Therefore, for such cases - in which the user effectively selects his own tape flux level for Dolby Tone - the following procedure is recommended:

Procedure C

For elevated recording level with elevated Dolby Level (user-selected).

1. Disconnect the 361 power (which de-energizes the relays) and press the 361 CHECK buttons to bypass the units both to and from the recorder.
2. Adjust both play and record aspects of the tape recorder for operation at the desired elevated recording level, including line level interfacing of the recorder with the console. Any test tape can be used. The input and output line voltages of the recorder must be the same (also recorder and console meter readings must match or at least have a known relationship; correct the meter calibrations if necessary). If the machine has separate sync level controls, they should be set to match play level.
3. Restore power to the 361 units and press the NORMAL monitor buttons to put the 361 units back into the circuit. Press the 361 REMOTE (play) buttons. Set the NR switches to the OUT (released) position.

4. Play the test tape used during recorder calibration (step 2 above) again and check the recorder line output meter reading. The playback level (and sync level) controls on the recorder should be trimmed, if necessary, so that the recorder line output level is the same as in step 2 above.

Note: No trimming should be necessary with bridging (10 kohm) tape return inputs on the console. With '600 ohm' tape return inputs, no trimming should be necessary if the actual impedance is reasonably close to 600 ohms (adjust impedance with extra resistors if necessary).

5. Use blank tape and put the recorder into record mode. Ensure that the recorder output switches are set to the 'playback' (from tape) position. Press the 361 REC buttons if the units are not wired for remote mode control by the recorder.
6. Press the 361 CHECK buttons.
7. Feed test tone at 0 VU level (or 5 dB below DIN peak level for European operation) from the console to the 361 units.
8. Adjust the INPUT controls on the 361 units (remove front-cover plates) until the 361 meters read on the DOLBY LEVEL dot.
9. Check that the 361 NR buttons are in the OUT (released) position. While recording the test tone, adjust the OUTPUT controls on the 361 until until the recorder meters and/or the tape return meters on the console give the same readings as would be obtained without the 361 units. This completes the alignment.
10. As a check on the alignment, continue recording and press the DOLBY TONE button on one 361 unit to record Dolby Tone (note: for correct routine operation of the Dolby system it is essential that all of the LINK DOLBY TONE connectors should be wired). The alignment is satisfactory if the 361 meters read within the DOLBY LEVEL dot while the DOLBY TONE button is depressed. This is independent of the type of test tape used during recorder calibration.

Note: If the 361 meter readings are outside the DOLBY LEVEL dot (e.g. due to '600 ohm' impedance discrepancies in the console and/or the tape recorder, as well as tolerances in the 361 units), then the recorder input level controls should be trimmed.

Simplified Procedure

The above procedure (steps 1 - 10) results in optimum consistency of meter readings throughout the whole audio chain (console, 361, recorder, 361, console), especially with consoles having 600 ohm tape return inputs. However, a simpler and often more convenient variation also gives good results, especially with consoles having bridging tape return inputs. The simplified procedure below does not require tone from the console for 361 alignment.

Procedure

Carry out all steps up to and including step 5 above. Then replace steps 6 - 10 with the following steps:

- 6a. While recording, press the DOLBY TONE button on one 361 unit (note: for correct operation of the Dolby system it is essential that all of the LINK DOLBY TONE connectors should be wired).
- 7a. Continue recording Dolby Tone and adjust the OUTPUT controls on the 361 units (remove front cover plates) until a level corresponding to 0 VU (or about 5 dB below DIN peak level for European operation) is obtained at the recorder.
- 8a. Continue recording DOLBY TONE and adjust the INPUT controls on the 361 units until the 361 meters read on the DOLBY LEVEL dot. Alignment is now complete.

After the calibration procedure C above has been carried out, it is normally unnecessary to make any further adjustments on the Dolby 361 units. Level variations due to changes in tape sensitivity should be compensated by adjusting the input level controls on the tape recorder. Furthermore, all adjustments for operation with different types of tape can be made on the recorder (including test tape changes, changes from normal to high output recording tape, and even changes in elevated level operating conditions - e.g. + 2 dB, + 3 dB, + 4 dB). This flexibility is an advantage of operating condition C. However, because Dolby Tone is not at a standard flux level, in contrast with operating conditions A and B, the disadvantage is that it becomes absolutely essential that Dolby Tone is always recorded at the beginning of each tape so that the tape can be properly decoded or over-dubbed at any time by any studio.

8.3 Operation

The following instructions apply for normal 361 operation, regardless of the conditions of operation or method of initial calibration (A, B or C above).

IMPORTANT

Whether playing your own tape or a tape from another studio, the Dolby warble tone already on the tape must read on the 361 Dolby Level dot.

1. Set-up

- a) Press all NR buttons, unless NR-OUT is required on any particular channel. Press the NORMAL monitor buttons. Press the REMOTE (play) buttons if the units have been wired for remote mode control by the recorder. Otherwise, it will be necessary to switch from record to play manually.
- b) The 361 units are now ready for use. The tape recorder is used normally, although if the recorder has input/playback monitor switches, the switches should be set to the playback (from tape) position.

2. Monitor buttons

- a) While the NORMAL monitor button is depressed, the 361 monitor output (back to the console) is the signal on line-in during record mode and the decoded tape signal during play mode. A normal (non-encoded) signal is thus heard at all times.
- b) The encoded signal directly from the tape may be monitored by pressing the CHECK button. The recording thus may be checked on a simultaneous record/play basis, although the signal heard will be in the encoded form. The CHECK buttons should not normally be operated when recording: the button switching logic includes appropriate line termination rearrangements, which may introduce a click in the recording.

3. Dolby Tone buttons

- a) It is essential to make a recording of the Dolby Tone calibration signal by pressing a Dolby Tone button at least at the beginning of each reel of tape. All of the LINK DOLBY TONE connectors must be wired. Record the tone on all tracks, even though not all may be used in the first session. Use of the Dolby Tone will ensure correct decoding or over-dubbing, including punching-in on existing tracks, at any time by any studio. Dolby Tone must

be recorded even if other normal studio tones are recorded as well. Note that Dolby Tone always warbles in a characteristic way for positive identification.

- b) When the DOLBY TONE button is depressed, Dolby Tone signal is sent to the recorder (on all channels in record mode) and the playback signal is automatically switched to read on the 361 meters. The complete recorder and 361 combination is therefore checked easily, both for signal continuity and level calibration. When the calibration is correct the 361 meters should always read on the Dolby Level dot, independently of the alignment procedure used.

4. Tape variations

- a) Note that the 361 units themselves are extremely stable. After the 361 units have been calibrated initially it will usually be found that any level discrepancies are due to recorder and tape variables.
- b) The recorder playback level should be trimmed by the use of the appropriate test tape (as used in alignment procedures A, B, or C above).
- c) A convenient way of compensating for a recording level discrepancy due to a change in tape sensitivity is simply to record Dolby Tone on blank tape and adjust the input level controls on the recorder until the discrepancy is eliminated.
- d) In any event, do not start adjusting the 361 units until after the recorder and tape have been thoroughly checked. When doing this, press and release the NR buttons (out). Alternatively, to bypass the 361 units completely, remove the 361 power (which de-energizes the relays) and press the CHECK buttons.

5. Tapes from other studios

- a) If you receive a tape from another studio, it is necessary to match the level of the Dolby Tone recorded on it to Dolby Level in your 361 units. For this purpose, disregard the levels of any other tones on the tape. Note that a Dolby Level discrepancy does not necessarily mean that the other studio has aligned its recorder and/or Dolby units carelessly: there may be a track width difference between your recorder and theirs (or, if the difference is as much as 2 or 3 dB, they are using a different Dolby Level standard from yours).
- b) If the Dolby Tone on the tape is outside the Dolby Level dot on your own 361 meters, then an adjustment should be made. If playback only is required, adjust the playback level controls on your recorder until the normal readings for Dolby Tone are obtained on the recorder meters. Your 361 meters should then indicate Dolby Level, with the NR buttons released or one DOLBY TONE button depressed (which inhibits the noise reduction action and eliminates a $\frac{1}{2}$ dB level discrepancy).

- c) If over-dubbing, especially punching-in, is required on some tracks, first make the playback adjustments in step (b) above, including sync level adjustments. Then record on a blank section of the tape with the DOLBY TONE button depressed. While recording, adjust the record level controls on your tape recorder until the normal readings for Dolby Tone are obtained on the recorder meters. Your 361 meters should then indicate Dolby Level.

8.4 Miscellaneous Notes

1. In the record mode, pressing any DOLBY TONE button energizes the Dolby Tone oscillators and connects the 361 meters to the off-tape (playback) signal. Another function of the DOLBY TONE button in both record and play modes is to inhibit the Dolby noise reduction action; at the Dolby Tone level and frequency (850 Hz) this action is $-\frac{1}{2}$ dB during recording and $+\frac{1}{2}$ dB during playback (i. e. overall no change). The button can therefore be used (instead of the individual NR buttons) to prevent a potential $\frac{1}{2}$ dB calibration error when playing back Dolby Tone.
2. If a check of the recorder playback frequency response is required at the console (using a test tape), the NR buttons must be released (NR out) in order to avoid confusion (at 0VU the Dolby system decode characteristic varies from flat by about $\frac{1}{2}$ dB in a pre-determined way; in normal use this is compensated during encoding). Overall record-playback frequency response at the console can be checked with the Dolby system in or out (since the response is flat overall). However, if a tone or frequency run from the console is to be left on the tape, noise reduction must be out.
3. To make a Dolby-encoded copy of a tape already made with the system, just copy the tape 'straight'. Copy the Dolby Tone at the same time for reference.
4. Use 'DOLBY A' stickers (Cat. No. 68) on your tapes to identify encoded recordings.
5. If the installation is wired for remote operation of the NR IN-OUT function, the buttons on the Model 361 units should normally be in the IN position. Note that the NR lamps on the units will be illuminated even if the remote switches are in the OUT position. For local operation of the NR IN-OUT function, the remote switches should be in the IN position.

8.5 Breakdowns

1. In the event of Cat. No. 22 Noise Reduction Module failure, simply remove the faulty module and plug in a good one. Modules can be swapped between channels if required. It is unnecessary to make any adjustments when changing a Cat. No. 22 module.

2. If a spare Cat. No. 22 module is not available, the channel can be bypassed by removing power or the remote plug (thereby de-energizing the relays) and pressing the CHECK button.
3. When sending a faulty module back to your Dolby distributor for repair or replacement, be sure to pack the module adequately. Include a note of the fault observed. Write on a piece of paper or on a sticker or masking tape (not directly on the covers of the module, as this ruins the anodized aluminium finish).

SECTION 9
MODEL 361 INTERFACE - CIRCUIT DESCRIPTION

9.1 Interface Assembly - Model 361

The interface assembly houses the Cat. 22 noise reduction module (NRM), power supply, meter and associated circuitry, input and output potentiometers, pushbuttons to control the module functions and monitor switching, and relays to switch the audio lines as well as to allow remote operation of the unit. Many of the components are mounted on a printed circuit board assembly, the physical layout of which can be seen on the drawings at the end of Section 11. Servicing. The interface circuit drawing (A0C369) is at the rear of this section, and may be folded out clear of the text for reference.

9.2 Power Supply

AC power is fed to a double primary transformer (T1) which can be set for 115 V or 230 V operation by means of a screwdriver-slot slide switch (S1) mounted on the rear of the unit. In the 230 V position the unit will operate on any power line voltage from 200 to 250 V, and over an equivalent range when 115 V is selected.

The ac output of the transformer, nominally 19 V, is fed to the bridge rectifier (D1) mounted on the printed circuit board. The resultant dc voltage is smoothed by capacitor C1, which is fixed by clips in the channel immediately behind the printed circuit. This raw dc supply is fed to the NRM by two routes: directly for power, and also as a record interlock signal in the record mode only (via RL3 and S4a) to the Dolby Tone logic circuits in the module. The internal function relays (RL1 and RL2) are powered from this dc supply.

The 19 V ac signal is also used to power the indicator lamps via appropriate contacts on the switches and relays.

9.3 Mode Switching

The mode switching in the Model 361 comprises two main functions; the NRM mode is connected either to Play or Record, and the signal connections to and from the NRM are re-connected appropriately. The mode control may be local, using the front panel pushbuttons, or remote via JF6. In both cases plug-in relays (removable through the front panel) perform the actual switching operations.

In the Play or Remote mode, noise reduction signals from pin 8 of the NRM are switched by relay RL1 to pin 9, the playback mode input. In the record mode, these signals are routed to pin 7 of the NRM. Pushbutton S2a (NR In-Out) earths the noise reduction signal in the Out position, converting the Model 361 unit into a fixed gain amplifier. This facility is used when making or playing back non-Dolby recordings, removing the necessity for patching the unit out of the circuit. The pushbutton is illuminated in the NR In mode.

When the Record button is depressed, +24 V dc is connected via S4a to the relays RL1 and RL2. Relay RL1 operates directly, but RL2 is connected to 0 V through transistor Q1. The function of Q1 is explained in sub-section 9.8. The Play button should be depressed for local operation of play mode.

For remote operation, the Play button should be depressed; in this case, record mode is obtained by connecting 24 V dc between pins 2 and 3 of the remote socket JF6, which will operate reed relay RL3. The internal +24 V will then be connected to relays RL1 and RL2 via S4a, which will switch the unit to record mode. The pushbuttons are internally illuminated, red for record and green for play. Since the voltage to these bulbs is switched by relay RL1, the illumination indicates the mode of the unit, irrespective of whether manual or remote operation is used.

The relays also switch the signal routing, which is described in detail in sub-section 9.4.

9.4 Signal Paths - to and from recorder

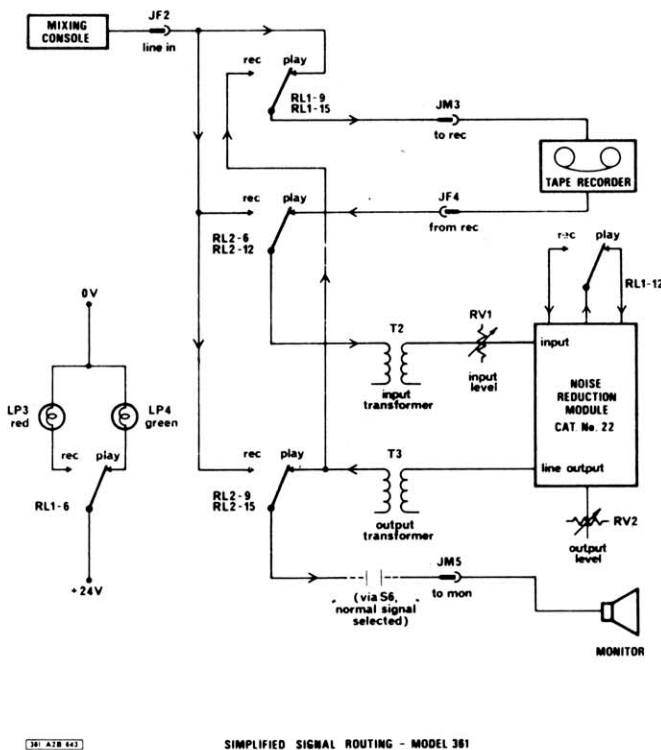

Fig. 9.1

The simplified signal routing diagram Fig. 9.1 above, read in conjunction with the complete fold-out Model 361 interface circuit diagram, shows the various possible signal paths.

Playback signals from the recorder are routed from connector JF4 (From Recorder) to the relay RL2-6 and RL2-12, and hence to the input transformer T2. The input impedance is 10 k, and by virtue of the isolated primary winding, the unit is suitable for bridging audio lines, whether unbalanced, balanced, or floating. The high-frequency resonance of the transformer is damped by resistor R1 mounted on the top surface of the printed circuit board (below serial number 361-01600, R1 was mounted on the transformer tagstrip). Trimpot RV1, Input Level, adjusts the

incoming level to suit the input requirements of the module. This control is accessible when the front cover plate is removed. The sensitivity of the Model 361 is such that a minimum input of about 350 mV is required at Dolby Level (185 nWb/m tape flux). Higher sensitivities can be provided with a special input transformer T2 or by the use of an additional amplifier between the output of RV1 and the input to the NRM; these special requirements should be specified at the time of ordering.

The output level control RV2 is the NRM line amplifier gain control, which enables the output signal corresponding to Dolby Level to be set at any voltage up to +16 dB. With the front cover plate removed, the control is accessible through a front panel hole.

The unbalanced output of the NRM is routed to the output transformer T3 through capacitor C4 (mounted under the transformer tagstrip), isolating the dc voltage component present at the module output. The transformer has a 1:2 step-up ratio, providing a maximum output signal in excess of +21 dBm into 600 ohms. Resistor R2 and capacitor C3 form a high-frequency damping network which damps the 500 kHz resonance of the transformer. This high resonant frequency is a consequence of the extremely low leakage reactance of the transformer, which is necessary to maintain a low output impedance (approx. 20 ohm) throughout the audio passband.

The balanced-floating secondary is routed in the play mode to the monitor output connector JM5 via the monitor switches S6, which will be described in detail in sub-section 9.5.

In the play mode, the signal from the mixing console is routed directly to the tape recorder input to maintain continuity. In the record mode, the mixing console signal is routed by RL2-6 and RL2-12 to the input of the NRM. The processed signal is sent via RL1-9 and RL1-15 and JM3 (To Recorder) to the tape recorder input.

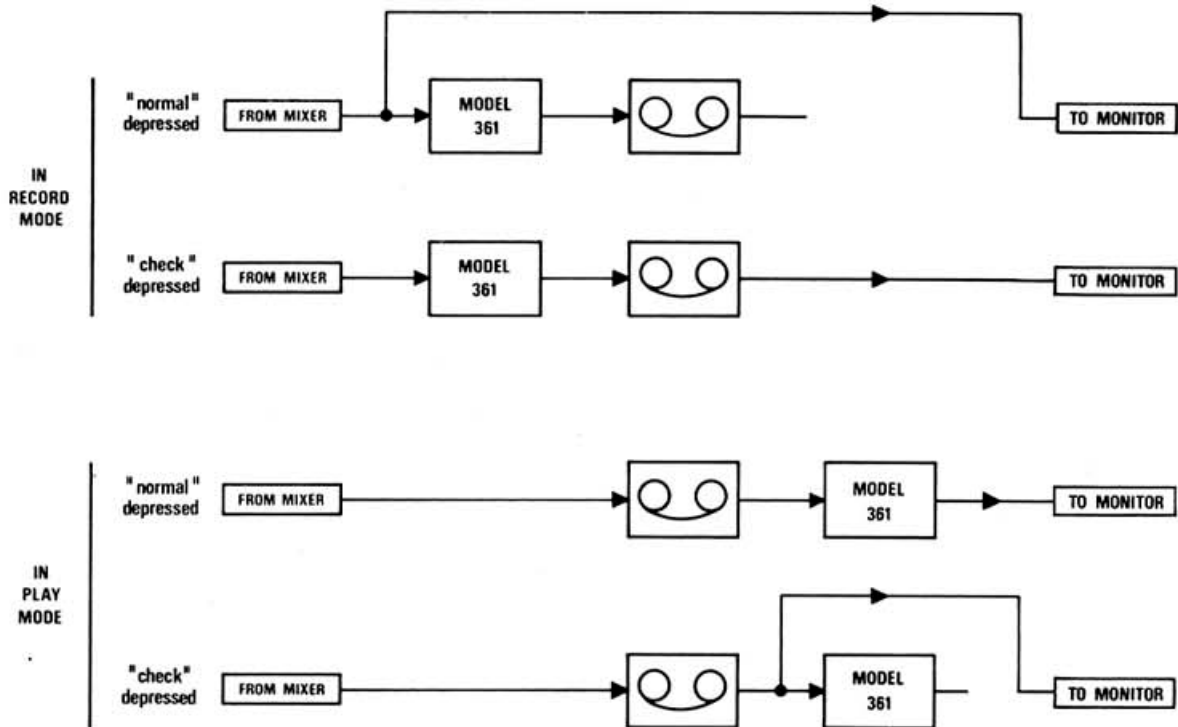
9.5 Monitoring Signal Paths

361 A2B 593

MODEL 361 "NORMAL" AND "CHECK" MONITORING ARRANGEMENT Fig. 9.2

The Model 361 monitoring arrangements are shown diagrammatically in Fig. 9.2. The signal appearing at the To Monitor socket JM5 is controlled by the interlocked pushbuttons S5 (Normal Signal) and S6 (Check Tape). Note that balanced floating lines are used in practice, although for clarity an unbalanced condition is shown in the drawing.

With the Normal Signal button depressed, the signal at the To Monitor socket is an uncoded (or decoded) signal at all times. In the record mode it is the line-in signal; in the play mode it is the decoded output from the unit. However, there are occasions when it is convenient to be able to monitor the signal directly from the tape, either to check that a recording is in fact being made, or to measure voltages. If the Check Tape button is pressed, the replayed signal from the tape recorder is fed to the monitor. Note that, if a Dolby tape is being made, this signal will be in encoded form.

As the Check Tape button is operated, connections are made to balanced isolated lines. Different potentials can exist between such lines due, for example, to leakage currents. If the Check Tape button is used during a recording, clicks may be recorded on the tape. It is recommended, therefore, that such switching should be done only during moments when possible clicks are unimportant.

9.6 Termination Conditions

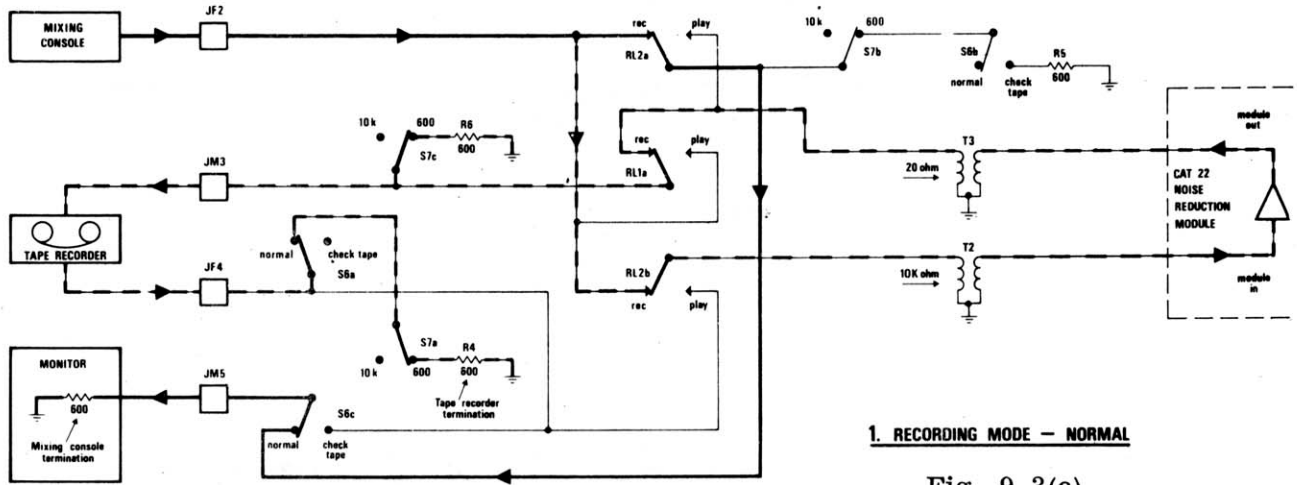

Fig. 9.3(a)

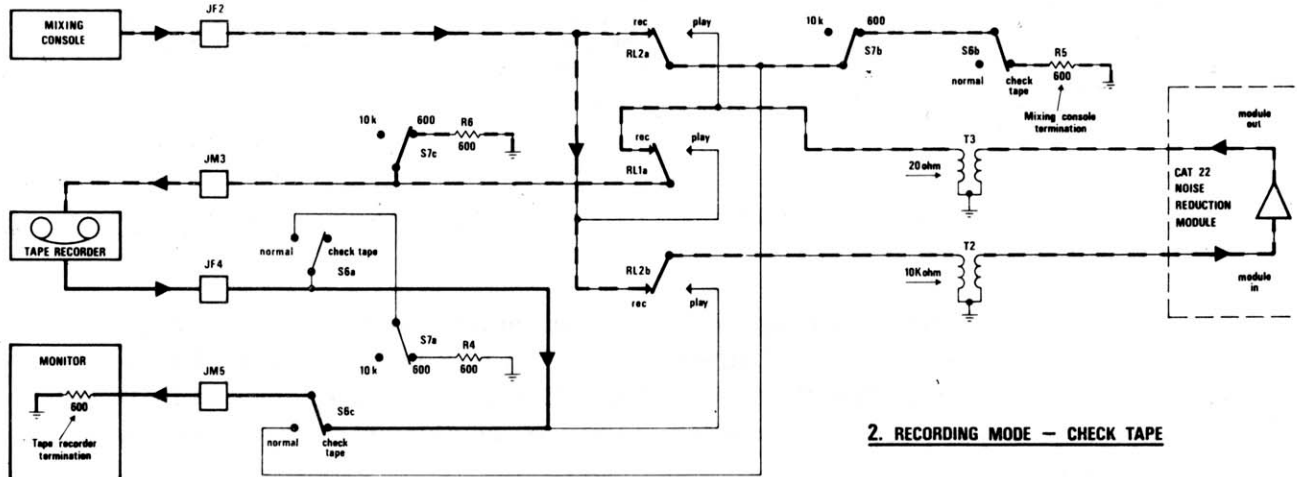

Fig. 9.3(b)

The 360 series units have high input impedance (10 k ohms) and low output impedance (20 ohms) so that they are relatively insensitive to normal studio impedances. The low output impedance is a great advantage in that the termination conditions can essentially be neglected. The 360 series units are designed to work properly into an open circuit; nevertheless, a 600 ohm load causes a level drop of only about 0.25 dB.

The switching arrangements on the Model 361 are designed to cater for the various impedance and termination conditions prevailing when the units are used with older equipment which may have higher output impedances (such as 600 ohms) and which may require termination either at the sending or receiving ends of the lines, depending on individual studio practices. These arrangements provide for the fact that the Model 361 processor module is switched between the record and playback sides of a tape recorder, and thus interrupts the normal termination conditions.

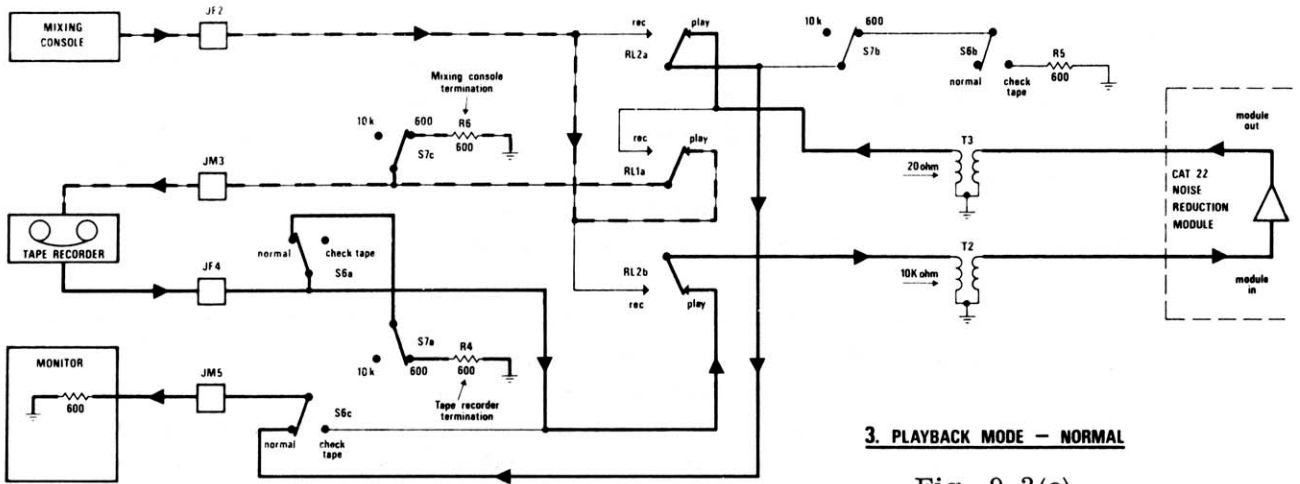

Fig. 9.3(c)

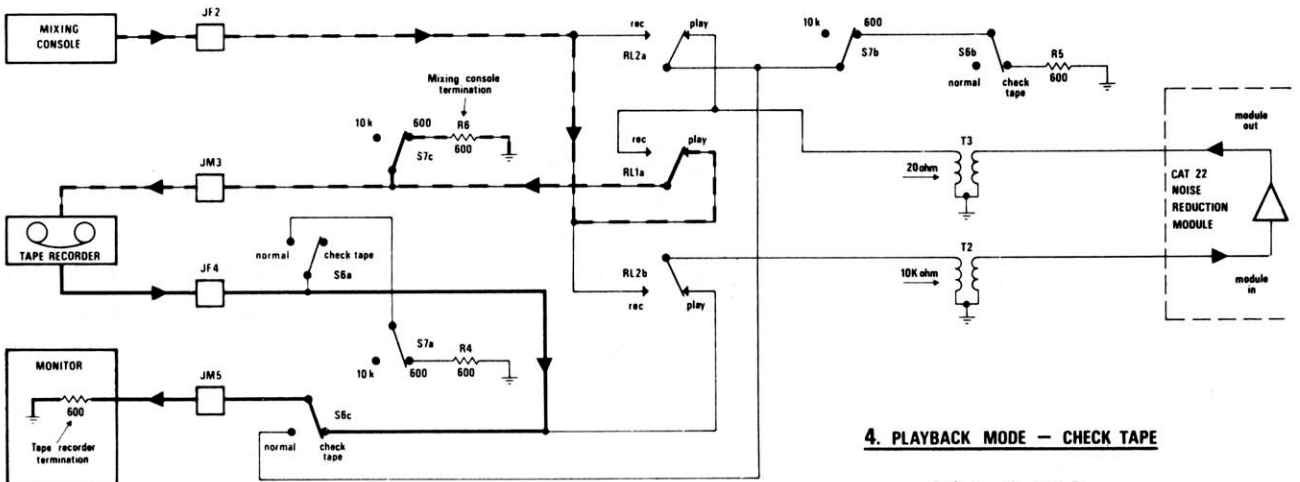

Fig. 9.3(d)

Further switching takes account of the operation of the Check Tape and Normal Signal pushbuttons, which shift the monitoring system (and its possible input termination) from point to point, these points differing in the record and playback modes.

A single switch S7 (600 ohms—10 k) on the rear of the unit accommodates all normally encountered combinations of source and termination impedances. If the equipment with which the Model 361 is being used is operated with the increasingly popular convention of high input (bridging) impedances and low (or terminated) source impedances, switch S7 is set to the 10 k position. If the recorder has a built-in 600-ohm termination switch, this should be in the "on" position.

If, however, the installation is operated with terminations on the inputs of the receiving equipment and fixed impedances at the outputs of sending units, then consistent

impedance conditions have to be maintained in the various switching configurations. If the monitor input impedance is 600 ohms, then switch S7 is set to the "600" position. If the recorder has a built-in 600-ohm termination switch, this should be in the "off" position.

By way of explanation, Fig. 9.3 shows all the possible connections of monitor, source, tape recorder, and Model 361 unit. The situation can be better understood by consideration of one example from Fig. 9.3. Assume that the monitor input impedance is 600 ohms; S7 will therefore be in the "600" position. In the record mode, and with Normal Signal selected, Fig. 9.3(a), the monitor is connected to the mixing console. The monitor thereby terminates the mixer output. The noise reduction module bridges the same mixer output.

If the Check Tape button is depressed, Fig. 9.3(b), the monitor is removed from the console output and connected to the tape recorder output. To avoid level changes under such conditions, a termination resistor (R5) is automatically switched across the mixer line. The resistor R4, which is connected across the tape recorder output in the Normal Signal condition, is disconnected and its place taken by the monitor impedance. A study of the remaining diagrams, Fig. 9.3(c) and 9.3(d), shows how resistors R4, 5 and 6 provide correct termination conditions at all times. These resistors are normally 600 ohms, 2%, so that if equivalent values are used in external equipment there will be no level changes when the mode and monitor functions are switched.

Non-standard Terminations

Non-standard conditions can be understood by reference to the four diagrams discussed above, and in some cases re-connection of the appropriate termination resistors may produce optimum conditions. In one such non-standard situation both the tape recorder and monitor may have 600 ohm input terminations; the mixer is therefore double terminated in the play condition by R6 and the tape recorder, but in the record mode the situation is correct. To avoid a change in level at mixer output, R6 may be removed (by lifting the appropriate wire from switch S7c connecting it to an unused pole of S7).

Another condition sometimes encountered is that of a 600 ohm mixer output which is terminated at the mixer, plus a 600-ohm monitor impedance. Under these conditions the mixer is permanently double terminated (by the mixer termination and by the monitor or by R6 or R5, depending on the position of the Model 361 switches). In such a case, the remedy is to remove the termination at the mixer output.

Sometimes monitor inputs have non-standard impedances, such as 2K ohms. In such an instance the monitor input should be paralleled with a resistor which brings the effective impedance down to 600 ohms. Switch S7 should then be set to the "600" position.

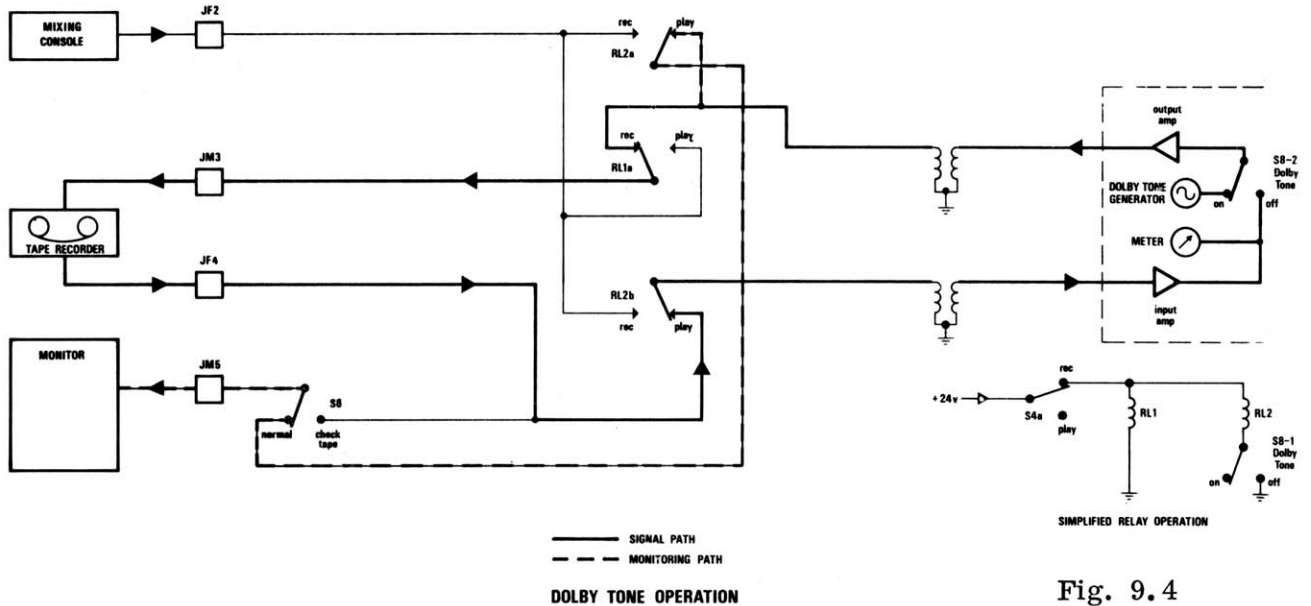
9.7. Dolby Tone Operation

The Dolby Tone oscillator in the noise reduction module (see Sections 5, 8, and 10) may be operated by the front panel pushbutton S5. This normally-open switch earths pin 3 of the module, switching on the oscillator. Capacitors C5 and C6 provide a small delay in the turn-off time of the oscillator and logic circuits, allowing the changeover relays to operate before the module signal transmission is re-established. Two capacitors are used in series to reduce the possibility of leakage currents.

The Dolby Tone on-off operating line is also brought out to two parallel-connected phone jacks (JF8, JF9) on the rear of the unit, allowing units to be linked together such that any front panel pushbutton operates all oscillators. The oscillator can also be operated remotely through these sockets; for distances up to 100 m (300 feet), two-conductor cables and a normally-open pushbutton switch can be used. For longer distances external relay control must be used; a switchable method is described in Section 7 (Installation) and is briefly mentioned in this section, sub-section 9.9.

As well as turning the oscillator on, pressing the Dolby Tone button in the Model 361 also alters the signal conditions as shown in Fig. 9.4. For the oscillator to operate, the unit must be in record mode; a record interlock signal (+24 V) is sent from the interface to the NRM (sub-section 10.8) to control the oscillator switch-on logic. Pressing the Dolby Tone button returns RL2 only to the play mode, thereby connecting the input of the NRM and its meter circuit to the tape recorder output. The module output, comprising the Dolby Tone signal, is still routed to the tape recorder input, however. The meter thus monitors the Dolby Level signal actually played back from the tape on a simultaneous basis, which allows the record level controls on the tape recorder to be set conveniently. Note that the signal actually heard is the signal from the oscillator. However, when the check switch S6 is depressed, the tape replay is heard.

The switching arrangements are shown in the Model 361 circuit diagram together with the simplified block diagram, Fig. 9.4. When the Dolby Tone button is not depressed, the on-off line rises to about +15 V. The base of transistor Q1 is connected via current-limiting resistor R3 to this line; Q1 is thus conducting under these conditions. Relay RL2 is connected in the collector circuit Q1, so that when the unit is in the record mode, in which +24 V is applied to the relays, both operate.

Earthing the on-off line causes Q1 to cut off, and hence RL2 reverts to the un-operated or play position; RL1, however, remains in the record position.

In the diagrammatic representation in Fig. 9.4, S8-1 represents the transistor switch Q1. Switch S8-2 represents the electronic switch Q808 in the noise reduction module, and is fully described in sub-section 10.8.

9.8 Meter Circuit

The noise reduction module contains a meter amplifier which provides an ac output signal related to the flux on the tape, which in turn is related to the operating parameters of the noise reduction system (see Sections 4 and 5). A Dolby Level tape flux of 185 nWb/m (Ampex-NAB level) produces a meter signal from the module of 1.85 V; a flux of 320 nWb/m, 3.2 volts, and similarly for any other flux level. The meter in the interface unit accepts these signals and displays them on a calibrated scale.

Referring to the Model 361 interface circuit, the meter signal is rectified by the voltage doubler D10 and D11 acting with the meter amplifier output capacitor in the NRM. The resulting dc is fed to the meter via a non-linear network R14 and D12, which linearizes the meter characteristics. With an input of 1.85 V, the input attenuator (R10) is factory-adjusted to give half-scale deflection, corresponding to the NAB mark. Under these conditions the voltage developed across the meter is less than 0.6 V, so that D12 does not conduct. As the input level is raised, this diode conducts, progressively shunting current from the meter. At an input of 3.2 V, R11 is factory-adjusted such that the meter reads DIN. DIN readings should be taken from a point directly in front of the meter (not on the axis of the needle).

The meter is internally illuminated by a miniature lamp LP1, which can be replaced through a hole in the side of the chassis. All the meter components are mounted on a printed circuit sub-assembly which is in turn fixed to the meter casing. The meter sub-assembly must be exchanged intact if meter replacement is ever required.

9.9 Remote Operation

The following functions can be remotely operated on the Model 361.

- a) Rec/Play
- b) Noise Reduction In-Out
- c) Dolby Tone operation

Detailed description of various methods of control will be found in Section 7, Installation. A brief outline of the methods used is included here.

a. Powered by external apparatus

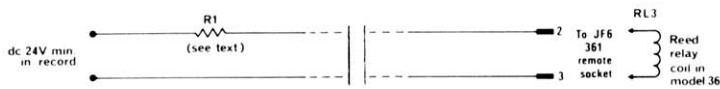

b. Internally powered

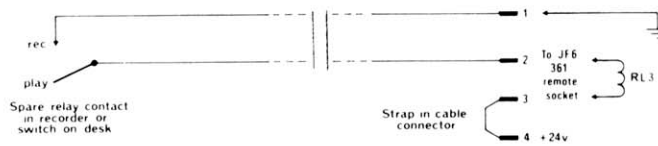

c. Internally powered with indicator

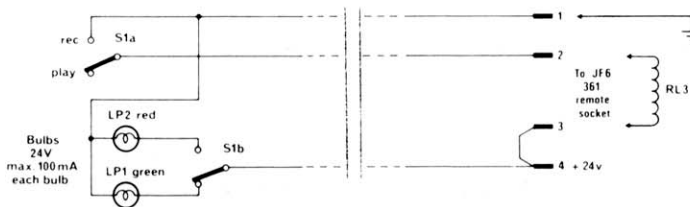

[81-A28-647]

REMOTE MODE SWITCHING - MODEL 361

Fig. 9.5

Remote mode switching is controlled by an internal reed relay RL3, requiring 24V at 6 mA for its operation. Power consumption is small, and current can therefore be taken from external equipment without fear of overload. Since the relay will operate with a voltage as low as 18 V, the Model 361 mode functions can be operated from a considerable distance before the voltage drop in cables becomes a problem. Fig. 9.5 shows three methods of control. Internally powered operation can be used, as shown in Fig. 9.5(b) and (c). For operation with a tape recorder, however, method (a) is usually to be preferred. Connected in this manner, the Model 361 then becomes part of the recorder, following its mode automatically. Resistor R1 is chosen to provide 6 mA for the relay from the voltages operating in the tape recorder; for 24 V dc circuits R1 is zero, for 40 V dc circuits it is 2.7 k, 0.5 W, for 110 V dc circuits it is 15 k, 1 W, and similarly for other voltages.

a. For distances up to 30m (100ft)

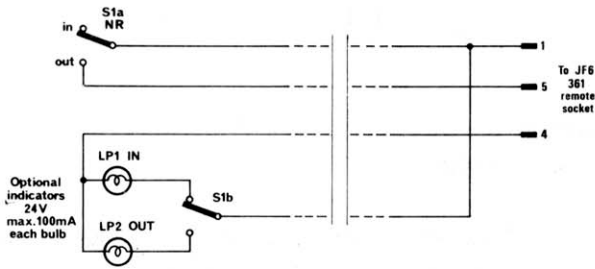

NOTES

- * 1. Separate leads must be used from JF6-1 to S1a and S1b to avoid hum loops.
2. Internal switch connected in parallel; must be depressed (NR'in) for remote operation.

b. For distances over 30m (100ft)

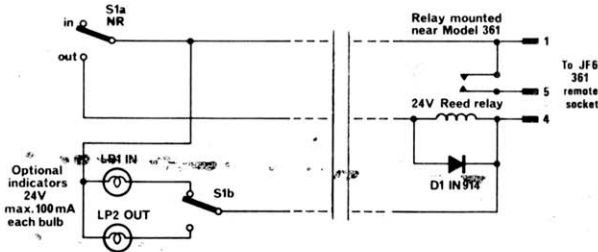

NOTE

1. Internal switch connected in parallel; must be depressed (NR in) for remote operation.

Fig. 9.6

[REPRODUCED]

REMOTE OPERATION OF NOISE REDUCTION IN-OUT MODEL 361

The noise reduction in-out may be remotely controlled, the noise reduction signal appearing on pin 5 of the remote socket JF6. This signal is fed from the noise reduction module at low impedance (100 ohms); earthing pin 5 thus removes the noise reduction action. Stray capacity connected across pin 5 will reduce the noise reduction action at high frequencies, so that the cable length used for remote operation is limited. Control at distances over 30 m (100 ft.) can be achieved using a reed relay mounted near the Model 361. Fig. 9.6(a) and (b) show both methods, including remote indication of the state of the unit. Note that since the interface NR In-Out switch S2 is connected in parallel to the remote switch, it must always be depressed (NR In) for correct remote operation. Furthermore, S2 remains internally illuminated even when the remote NR switch is in the Out position.

The wiring of the remote switches and indicators must follow that shown in the diagrams to avoid the generation of hum loops. Separate leads must be used for the lamp return and NR earth return; for similar reasons, the Model 361 earth (JF6, pin 1) must be used for these purposes and not a remote earth point.

If both the remote mode and NR In-Out switches contain lamps or control indicators which are powered from the Model 361, note that the total current availability is 100 mA. Thus each bulb may not draw more than 50 mA.

The Dolby Tone function may also be remotely controlled. The oscillator is operated by earthing the On-Off line of the NRM, which is brought out to JF8 and JF9 (phone jacks) on the rear of the unit. If there is appreciable resistance (e.g. 100 ohms or more) in the earthing connection, the oscillator frequency and amplitude change. For remote operation at distances up to 100 m (300 ft.) the resistance of two-conductor cable has an insignificant effect on the oscillator. For operation at distances in excess of this, a reed relay can be mounted near the unit. Fig. 9.7 shows a typical arrangement.

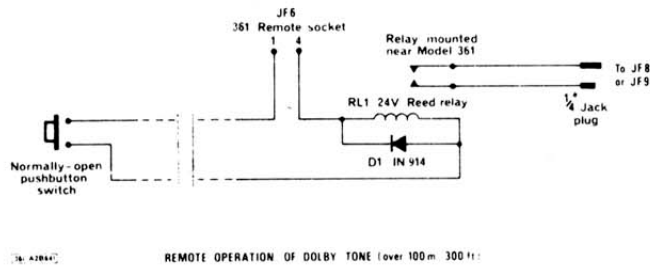
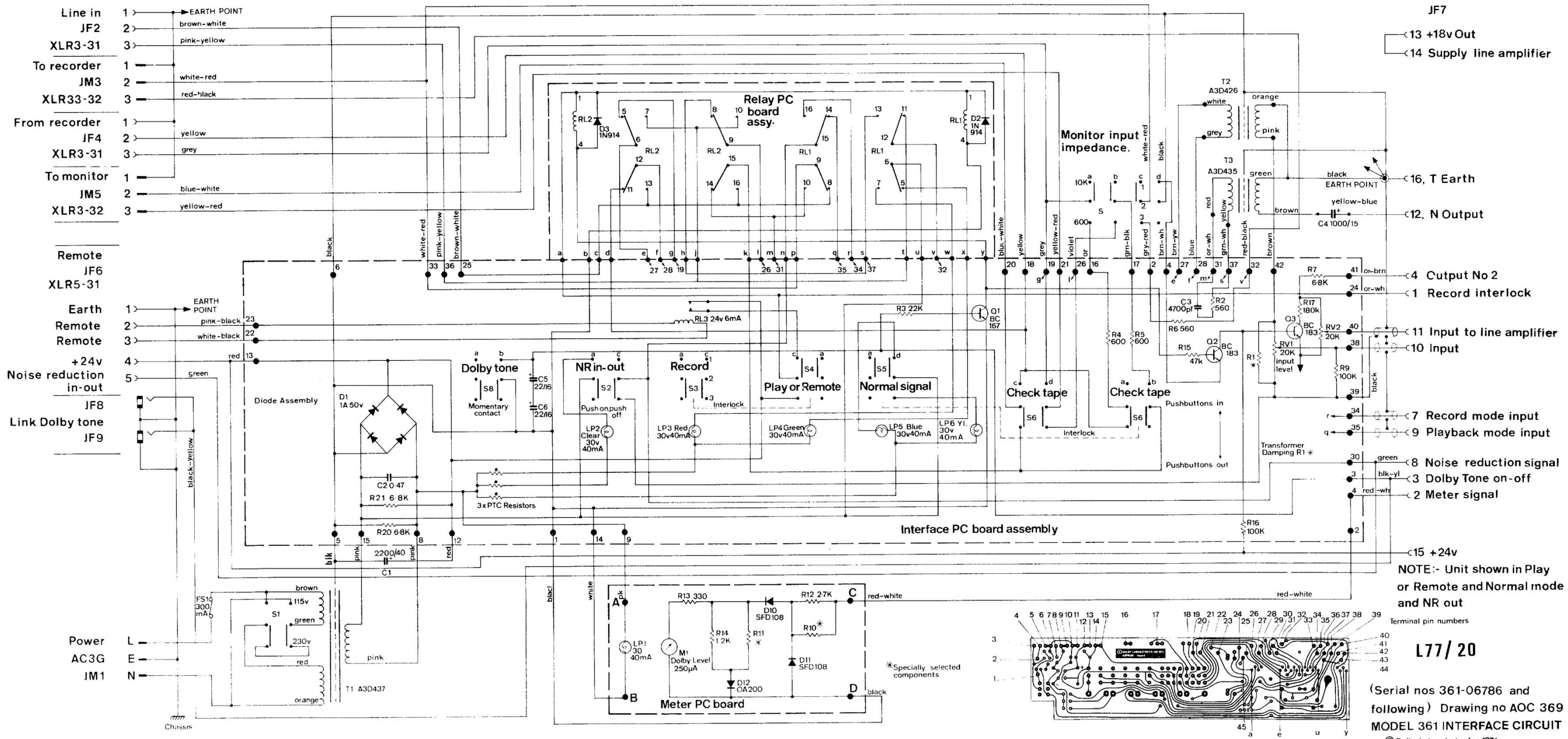

Fig. 9.7



(Serial nos 361-06786 and following) Drawing no AOC 369
MODEL 361 INTERFACE CIRCUIT
 © Dolby Laboratories Inc. 1971

SECTION 10

CAT. NO. 22 NOISE REDUCTION MODULE - CIRCUIT DESCRIPTION

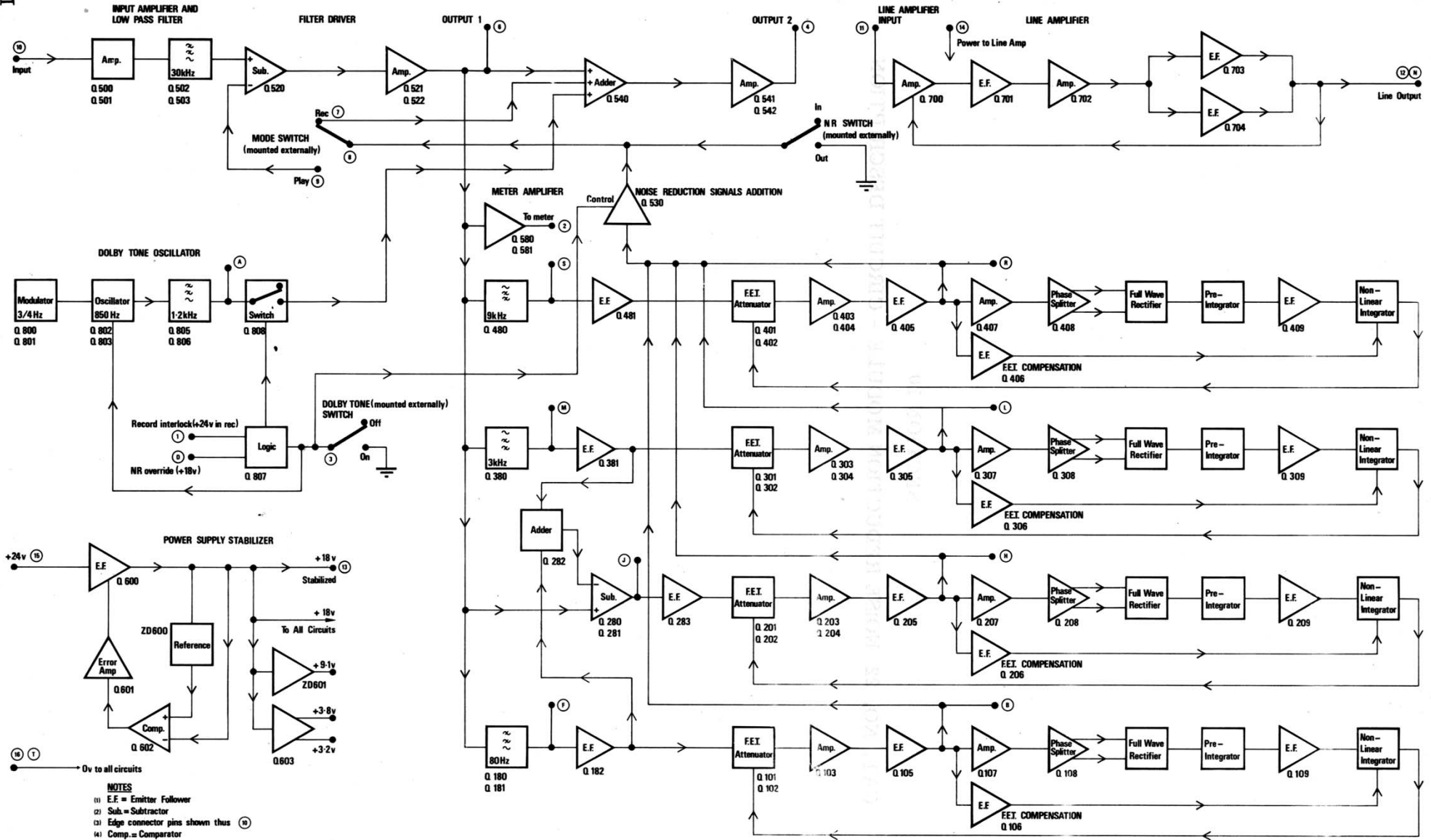

- NOTES**
- 1) E.F. = Emitter Follower
 - 2) Sub. = Subtractor
 - 3) Edge connector pins shown thus ④
 - 4) Comp. = Comparator

10.1 Introduction

The block diagram on the opposite page outlines the electronic sections of the noise reduction module. The main signal path is shown along the top, from the Input Amplifier through Filter Driver, Output 2 Amplifier, and finally Line Amplifier sections. The side chain signals pass through the filters and compressors, are combined, and then combined additively or subtractively with the main signal.

Each section will be described in turn, and will be preceded in the text by its circuit diagram. In these, the convention is adopted of main signal paths being shown by a heavy solid line, feedback paths by a light outlining of the signal line, and noise reduction signal paths by a solid dotted line. The complete circuit diagram is given at the end of the Cat. 22 section of this manual.

10.2 Power Supply

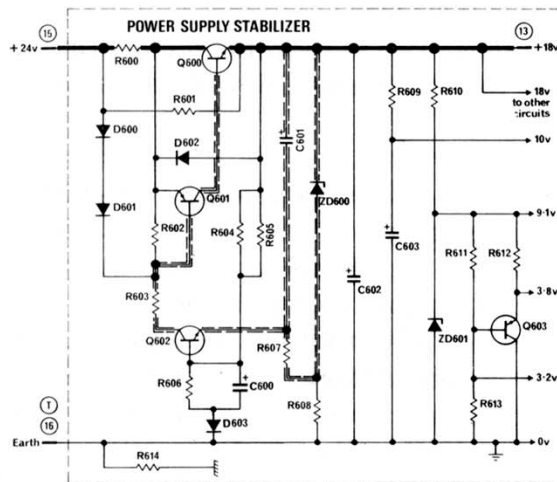

The Power Supply Stabilizer receives a roughly smoothed dc voltage (+24 V nominal, but with a minimum value of +19.5 V, including negative ripple excursions) and stabilizes this to $18.0 \text{ V} \pm 0.3 \text{ V}$. The current supplied by the stabilizer is 105 mA, with a further 10 mA for the Line Amplifier. At high output levels, the Line Amplifier requirements reach a peak of 100 mA.

Transistor Q602 functions as a comparator, responding to the voltage difference between base and emitter. The zener action of ZD600 ensures that the emitter is always a constant 6.8 V below the output voltage; the base is held at a slightly higher voltage by the divider R605 and R606.

The operation of the circuit is best explained by considering the results of a change in output. If more current is demanded, the output voltage will tend to fall. Transistor Q602 emitter falls by the full amount of the change (since the voltage across ZD600 is always constant), but the base is held at a constant voltage by C600 for rapid changes;

for slower changes the base falls to a lesser degree owing to the potential divider action of R605 and R606. Transistor Q602 thus passes more current, and the resulting fall in collector voltage is amplified and inverted by Q601. The output voltage rises, counteracting the initial output voltage drop; the reverse action occurs if the output voltage rises. The series regulator transistor Q600 is bolted to a small heatsink which dissipates about 850 mW with a rough supply of 24 V.

In addition to voltage stabilization, the circuit also provides for foldback current limiting. If an increased current is demanded from the stabilizer, the voltage drop across R600 increases; Q601 then passes more current. When the voltage drop across R600 is greater than 0.7 V, diodes D600 and D601 conduct and clamp the base potential of Q601. Thus no more current will flow, and the output is current-limited. If the load is increased, the constant current mode progressively collapses into a foldback characteristic. Under short circuit conditions, the current flowing is typically 15 mA.

The module also produces a secondary supply of 10 V, a zener diode 9.1 V supply, and two voltages (3.2 V and 3.8 V) that are related by the base-emitter voltage of Q603. The difference in these two is therefore temperature-related, and this thermal dependence is used to compensate for variations which occur in the limiter circuits.

It is also possible to operate the processor module from batteries or other external supplies. A ripple-free voltage of about +18 V can be applied to pin 13; all parts of the circuit which are significantly voltage-sensitive are supplied from the 9.1 V supply, which is fully stabilized by the action of zener diode ZD 601. Diode D602 prevents transistor Q600 from becoming reverse-biased. The module operates correctly at lower supply voltages down to about +16 V, but with reduced output capability. The current requirement is dependent on the supply voltage used, 115 mA being drawn at +18 V. The maximum voltage which can be applied to pin 13 is 28 V; higher external voltages or supplies with ripple present should be applied to pin 15 with series resistors if necessary to limit the voltage at pin 15 to 30 V.

10.3 Input Amplifiers

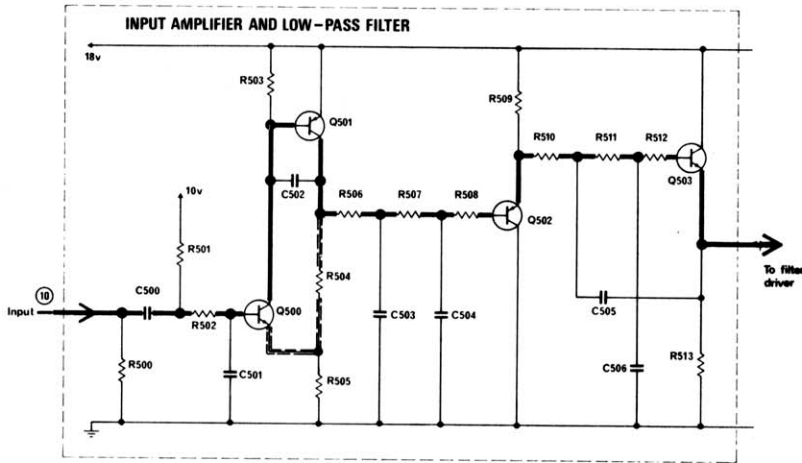

Input signals are applied to the input stage via an RF filter (R502 and C501). Transistors Q500 and Q501 function as a high input impedance unity-gain amplifier. The maximum sensitivity of the module is 300 mV for Dolby Level (corresponding to a magnetic tape flux level of 185 nWb/m, Ampex Operating Level). Transistors Q502 and Q503 form a two-stage active 34 kHz low pass filter, which prevents tape recorder bias or high frequency interference from entering the module and affecting the noise reduction circuitry.

10.4 Filter Driver

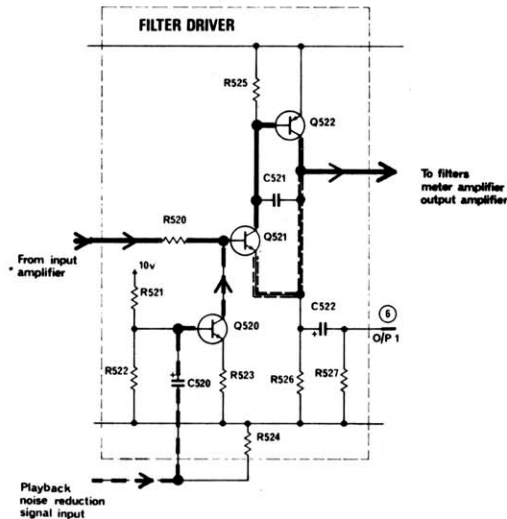

Transistors Q521 and Q522 act as a high input impedance, low output impedance unity-gain amplifier, which is designed to feed the filter amplifiers. The noise reduction signal (which will be described in detail in Sections 10.9, 10.10, and 10.11) is routed in the playback mode to Q520, via pin 9. At pin 9 it is in phase with the signal at Q503 emitter; the inverting action of Q520 causes the noise reduction signal voltage developed across R520 to subtract from the main signal path voltages. A reduction in gain at low playback signals is thus achieved (see Section 4).

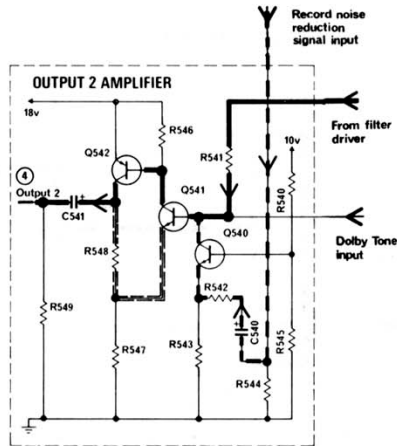
10.5 Output 2 Amplifier

The main path continues to Output 2 Amplifier; Q541 and Q542 are arranged in a feedback amplifier configuration to raise the 300 mV signal to 500 mV. The output signal (pin 4) can be used independently; for example, in situations where the module is an integral part of a tape recorder, this signal would go via a preset calibration control to the record amplifier input.

In the case of the Model 360, 361 and 364 Noise Reduction Units it passes via a potentiometer (Output Level) to the input of the Line Amplifier.

The noise reduction signal is applied in the record mode to Q540 emitter; being in phase with the signal at Q522 collector, the noise reduction signal adds to the main signal in R541 to provide the desired record characteristics (see Section 4).

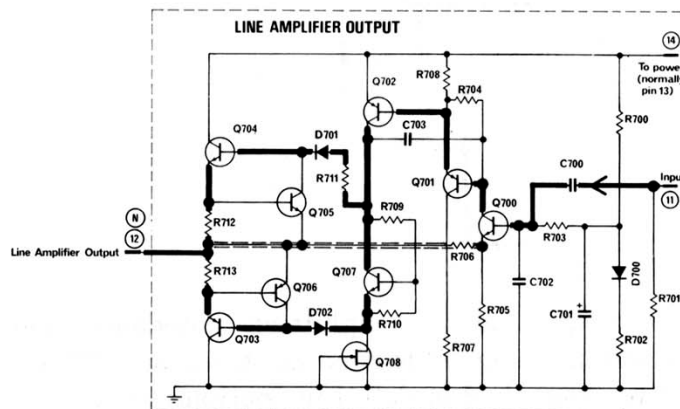
10.6 Line Amplifier

The module contains an independent line amplifier, with an input on pin 11 and an output on pins 12 and N. The amplifier can be fed from any signal—for example from Output 1 or Output 2 via appropriate attenuators. The amplifier is designed

to feed a 1:2 transformer to provide balanced or floating outputs. The normal input level is 90 mV for a 600 mV output (e. g. 1.23 V, +4 dBm with the transformer). Via the transformer, the clipping level is +16 dB (relative to 0 dB = 0.775 V) into 200 ohms or +21 dBm into 600 ohms when powered from the internal 18 V supply (pin 14 strapped to pin 13). Higher outputs, at slightly higher hum levels, can be obtained by connecting the positive voltage rail (pin 14) directly to the +24 V rough supply (pin 15). Still higher output levels can be obtained by using an external higher voltage connected directly to pin 14. This external voltage should not exceed 40 V, and should have a maximum ripple content of less than 1 V peak to peak.

Transistors Q700 and Q702 form a voltage amplifier, with Q701 isolating the two gain stages. Transistors Q703 and Q704 are complementary-symmetry emitter followers, whose quiescent current is determined by the amplified diode arrangement Q707, R709, and R710. Negative feedback is taken from the output to the emitter of Q700 via R706 to determine the gain and raise the input impedance. Transistors Q705 and Q706 act as current limiters; if, for example, high positive-going currents are demanded from the output stage, the voltage across R712 must rise and hence the base voltage of Q705 rises. Eventually Q705 conducts and limits the base voltage on Q704, thereby limiting the output current. Similarly on opposite half cycles, transistor Q706 operates. Thermal protection is provided by mounting transistors Q707 and Q704 in a single copper clip; any rise in the output stage temperature is transferred to transistor Q707, reducing the collector-emitter voltage and hence reducing the output stage current. Thermal runaway is thus prevented.

10.7 Meter Amplifier

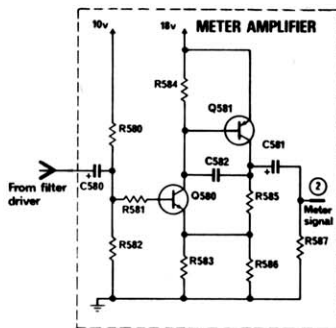

The meter amplifier comprises transistors Q580 and Q581, which function as an amplifier with low output impedance for driving a suitable meter incorporating rectifier diodes. The amplifier is driven from the filter driver output (Output 1), which is called the reference point. All compressor characteristics are related in a fixed manner to the voltage at this point. Level calibration of the unit is thus achieved when the input voltage (from the tape recorder, for example) is adjusted to read the correct level at this point. A reference level, called Dolby Level, can be related to the operating standards of the medium with which the noise reduction system is used. In professional tape recording, Dolby Level corresponds to a tape flux of 185 nWb/m (Ampex Operating Level), which should be replayed to give 300 mV at the reference point; the meter amplifier then produces 1.85 V at pin 2. Similarly, if a reference tape flux of 320 nWb/m is the standard in use (European practice), the meter amplifier produces 3.2 V at pin 2. The amplifier gain is precisely set during manufacture by selection of R583. Pin 2 can be connected to any suitable meter via an appropriate attenuator.

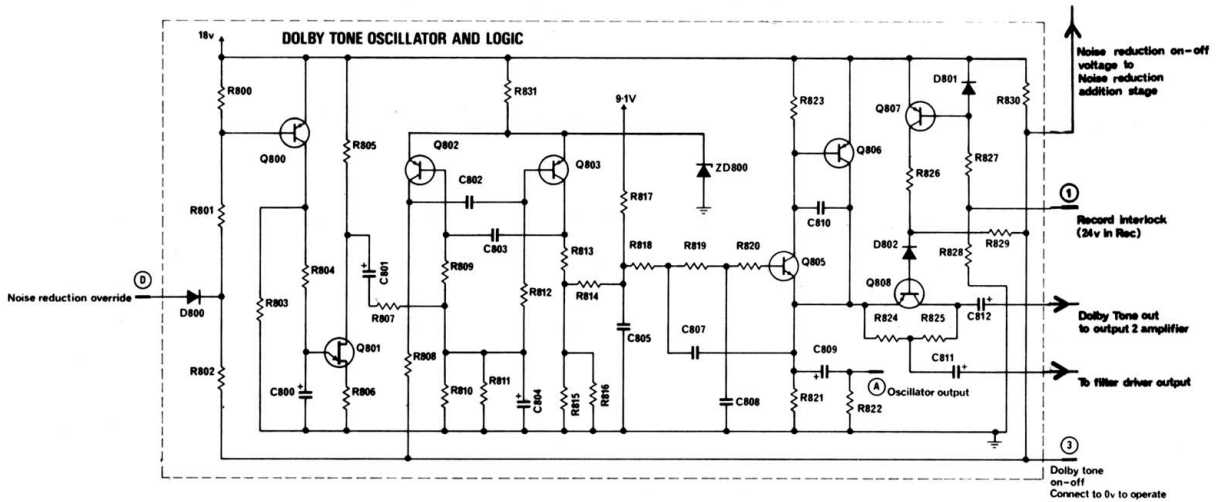
10.8 Dolby Tone Oscillator

To assist in recorder gain calibration and level setting, each module includes a built-in oscillator. The output of the oscillator is injected into the signal circuit at a level corresponding to Dolby Level.

Transistors Q802 and Q803 form a 850 Hz multivibrator, which oscillates when pin 3 is earthed (by operation of an external push-to-make Dolby Tone switch). In multichannel installations, the Dolby Tone on-off line (pin 3) of all channels may be commoned, so that a single switch operates all modules. The square wave output from the oscillator passes to a three-stage active filter. The output from Q805 and Q806 is a sine wave of approximately 2% total harmonic distortion. For use with the NRM Tester (Cat. No. 35) this output is available on pin A.

Transistor Q808 is an electronic switch; in one condition it presents a high impedance, in the other a low impedance. With the switch in the low impedance mode, the oscillator output is routed to the input of the Output 2 amplifier. Since the output impedance of Q805 and Q806 is low, any signals from the filter driver will be almost completely attenuated by the action of R541 (10 k) working into this low impedance. However, any such signals will nevertheless register on any meter connected to the meter amplifier. This facility can be used during record gain calibration, when pressing the Dolby Tone switch can be arranged to feed Dolby Tone to the record amplifier in a tape recorder, while leaving the input amplifier of the noise reduction module connected to the playback side. The meter will then read the Dolby Tone signal actually played back from the tape, allowing the record level controls on the recorder to be set precisely.

The electronic switch itself is programmed to operate only in the record mode of the tape recorder. Under record mode conditions, a +24 V record interlock signal is applied to pin 1, turning transistor Q807 off. If pin 3 is earthed, the

base of Q808 is made more negative than the emitter, which is held at about +3.5 volts by Q805 and Q806. Transistor Q808 therefore conducts. If pin 3 is not earthed, the voltage rises to about +15 volts, which turns Q808 off.

If the 24 volt record interlock signal is not present on pin 1, then Q807 will conduct. The base of Q808 is thus held more positive than the emitter, which prevents the electronic switch from conducting, whether or not pin 3 is earthed. Note that earthing pin 3 will still turn the oscillator on, providing an output at pin A for use with the NRM Tester. However, under these conditions the output will not be injected into the signal circuitry via Q808.

To equalize the dc voltage component across the transistor switch Q808, a resistor must be added from emitter to collector; if the switch is to have a high on-off resistance ratio, the value of this resistor must be large. To avoid the use of high value resistors, two resistors of comparatively low value (R824 and R825) are used with their centre point bootstrapped via C811 to a low impedance point carrying the same signal as is present on Q808 collector.

The Dolby Tone on-off line (pin 3) is also connected to the noise reduction signals addition stage, described in Section 10.11. When pin 3 is earthed, the noise reduction action is electronically removed. Note that this action occurs in both the record and playback modes. Since the on-off line may be paralleled for simultaneous operation of all channels in a multichannel installation, this allows a single switch both to turn on all oscillators for record calibration and to remove the noise reduction action during playback calibration.

To make the Dolby Tone distinctive, it is frequency-modulated. Transistor Q801 is a unijunction device, functioning as a relaxation oscillator. When pin 3 is earthed, a current is fed from Q800 into C800, which slowly charges up towards +18 V. When the peak point emitter voltage of the unijunction is reached, the base emitter junction becomes low impedance, discharging C800. The interbase resistance is low, and the resulting current flow produces a negative-going pulse in R805. Transistor Q801 then reverts to its off state, and C800 recommences its charging cycle. The time constants are arranged to produce a 30 msec pulse with a period of 750 msec. The pulse is applied to the multivibrator timing resistors R809 and R812, raising the frequency by approximately 10% for the pulse duration.

To avoid confusion when the oscillator is used with the NRM Tester, the frequency modulation is removed. In these circumstances pin D is taken to a voltage of +18 V or higher, so that Q800 becomes non-conducting. Capacitor C800 cannot charge, and hence Q801 will not oscillate.

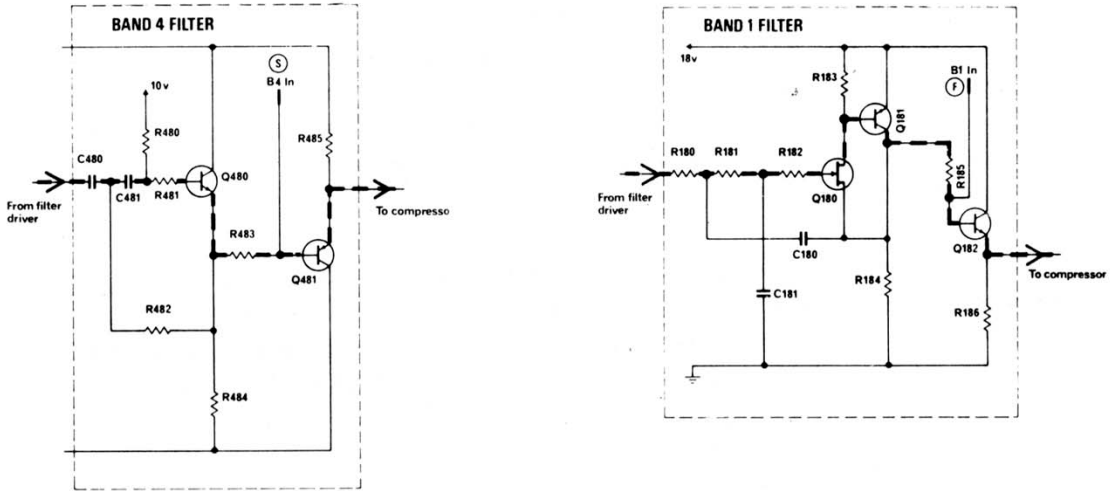
10.9 Filters

The side chain or differential path commences at the output of the filter driver Q521 and Q522. This stage drives the four filters, which split the audio signal into four frequency bands. The output from each of these bands passes through an independent low-level compressor before being combined to form the noise reduction signal which is then re-introduced to the main signal path. Bands 3 and 4 are both high-pass filters of identical circuit configuration with changed component values; only Band 4 is shown above.

Transistor Q480 is an active high pass filter, with the components C480 and C481, together with R480 and R482, chosen for a cutoff frequency of 9 kHz. Transistor Q581 is an emitter follower. Similarly, Q380 forms a 3 kHz high-pass filter. A rearrangement of capacitors and resistors in a similar circuit around Q180 forms an 80 Hz low-pass filter. In this filter a field effect transistor is used to raise the input impedance (allowing small value capacitors to be used) and the transistor amplifier Q181 is used to provide a low output impedance.

The band 2 filter provides for a band-pass characteristic from 80 Hz to 3 kHz, with an amplitude and phase response which is complementary to that of bands 1 and 3. This is achieved by subtracting the outputs from band 1 (80 Hz, low pass) and band 3 (3 kHz, high pass) from the wideband input signal.

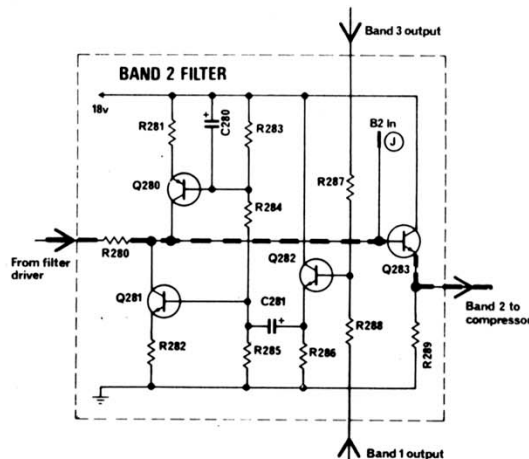

The outputs of bands 1 and 3 are added at the base of Q282 by R287 and R288, and then inverted by Q281. The collector current is thus proportional to the outputs of bands 1 and 3, but is out of phase. This difference signal is combined with the wide-band signal by R280, providing the required signal in the band 80 Hz to 3 kHz, and passes to the Band 2 compressor via emitter follower Q283.

To avoid a dc voltage drop in R280 which would reduce the dynamic range of stage Q281, Q280 provides a constant dc current which is equal to the average current of Q281; hence, no significant dc current flows in R280.

10.10 The Compressors

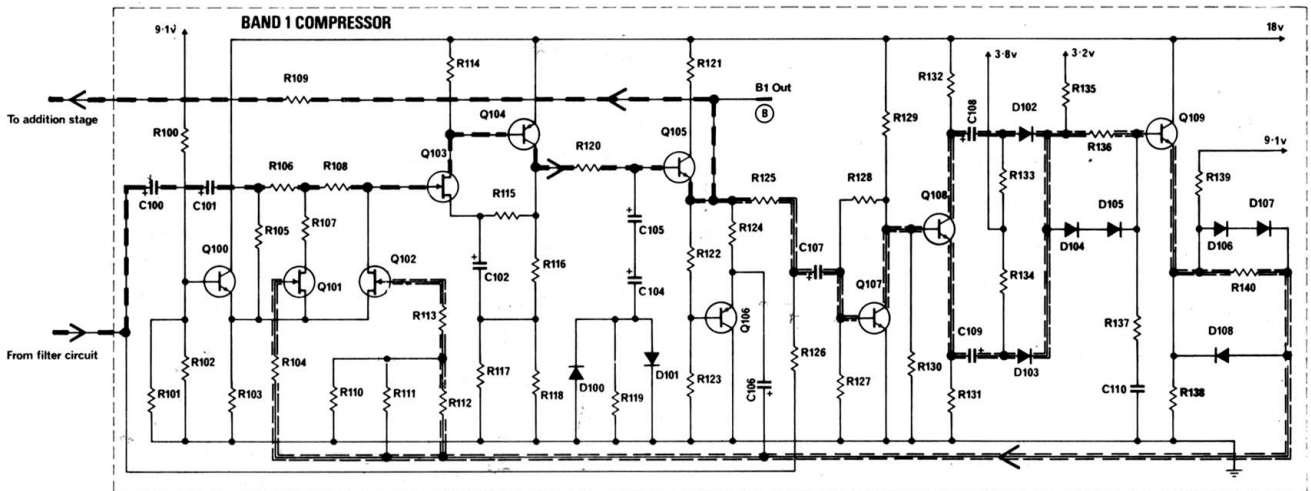

The compressors in all four bands are substantially identical, and thus only that of band 1 need be described. The signal from each filter enters the compressor and under low level signal conditions is passed unattenuated to Q103 and Q104, an amplifier with a very high input impedance produced by the field effect transistor Q103. Transistor Q105 is an emitter follower; the output is taken via R109 to the noise reduction signals addition stage. The overall signal gain of the compressor is precisely set during manufacture by selecting R117.

The control signal amplifier comprises the amplifier Q107 and phase splitter Q108. The audio signal is rectified by D102 and D103, and the resulting dc is smoothed in the pre-integrator R136 and R137 together with C110. The pre-integrator output passes via Q109 to the final integrator R140 and C106. The time constants of the integrators in bands 1 and 2 are twice those in the higher frequency bands.

Both pre- and final integrators have non-linear characteristics produced by the diodes D104-D108. Fast, large changes in signal amplitude are passed quickly, whereas small changes are transferred slowly. This dynamic smoothing action produces optimum results with respect to modulation effects, low frequency distortion, and distortion components generated by the control signal. The circuit achieves both fast recovery and low signal distortion; in conventional arrangements these two criteria are mutually exclusive.

The resulting dc control signal is fed to the gates of the field effect transistors Q101 and Q102, which act as variable resistances in two series L-attenuators. The control voltage applied to Q102 is a dc offset and slightly attenuated version of that to Q101. Both FETs are factory-selected for similar pinch-off voltages, so that as the control voltage rises, first Q101 and then Q102 conducts. The attenuation produced by Q101 is limited by R107 working against R106 and the source-drain resistance of Q101. Therefore the rate of change of attenuation is gentle. As the signal level increases, the rising control voltage causes Q102 to conduct, and the rate of attenuation increases. The source voltage is factory-adjusted by R101 and R102 to compensate for differing pinch-off voltages of the FET pair. Similarly, R111 and R112 are adjusted to match the required precise compressor curve. R105 maintains dc conditions across the FET pair.

At high signal level inputs, it is desirable to reduce the compressor output still further, so that the noise reduction signal represents a negligible proportion of the main signal. To achieve this, some of the input signal to the compressor is fed forward around the attenuator section through R126. Under low-level signal conditions, when Q101 and Q102 produce no attenuation, the output from the amplifier (passing through R125) is considerably greater than the feed-forward signal. As the attenuator operates, the proportion of feed-forward to normal signal entering the control signal path increases, until eventually primary control is produced by the feed-forward component. This in turn produces the down-turning curve of the compressor input-output characteristic.

FET compressors produce even-order distortion components unless correction techniques are used. While this distortion can be reduced by operating the FET in a push-pull configuration, it can be shown that this is equivalent to adding half the ac drain signal to the gate terminal. In the Cat. No. 22 compressor circuit this is achieved by taking the correct proportion of the FET output signal and adding this in series with the dc gate control voltage. Transistor Q106 adds this signal, at the same time providing the low impedance necessary for smoothing the dc control signal by C106. Resistors R122 and R123 form an attenuator to compensate for the gain of Q103 and Q104, reducing the ac signal on the emitter of Q106 to half that on the base of Q103.

Diodes D100 and D101 form a non-linear limiter circuit to prevent transient overshoots of the noise reduction signal during the compressor attack period. Under normal signal conditions the diodes are non-conducting, but under extreme transient conditions the diodes limit the noise reduction signal to a level which results in an overall output overshoot of less than 2 dB. The limited overshoot condition applies for about 1 msec only and is inaudible; when added to the high-level main signal, the noise reduction signal represents a very small proportion of the total signal. Two series capacitors C105 and C104 are used to prevent leakage currents forward-biasing the diodes.

10.11 Noise Reduction Signals Addition Stage

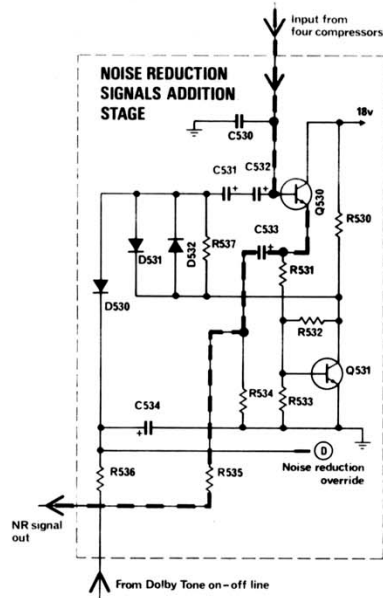

The outputs from the four compressors are fed to the addition stage via mixing resistors R109, R209, R309, and R409. Transistor Q530 is an emitter follower providing a low output impedance noise reduction signal.

If the limiting diodes D100 and D101 are operative in two or more bands, the transient signals from the compressors will combine additively. Under these conditions diodes D531 and D532 conduct, reducing the amplitude of the combined transient without any further limiting of the noise reduction signal itself. Amplifier Q531 provides an out-of-phase signal to the lower end of the diodes, to provide correct threshold conditions for the diodes and the signal levels present at this point.

The noise reduction signal appears on pin 8 and is connected to the record mode input (pin 7) or playback mode input (pin 9) by a suitable external single pole changeover switch. By earthing pin 7 the noise reduction signal is cancelled; the module then becomes a linear amplifier.

The noise reduction action is also removed by operation of the Dolby Tone oscillator. Under normal conditions D530 is reverse-biased by the positive voltage difference between the collector of Q531 (+6 V) and the Dolby Tone on-off line (+15 V on pin 3, to which D530 is connected via R536). However, when the Dolby Tone oscillator is operated by earthing pin 3, D530 conducts and short-circuits the noise reduction signal. This facility is useful during the playback calibration procedure, especially in multichannel installations where the Dolby Tone on-off lines may be connected together.

Certain modes of the NRM Tester require that the oscillator should work and also that the noise reduction signal should be available. The NRM Tester therefore feeds +18 V into pin D in these modes, so that D530 is maintained in the non-conducting state even when pin 3 is earthed.

10.12 General Notes

To facilitate incorporation of the NRM into tape recorders and mixers, all inputs and outputs are in phase. Furthermore, all outputs are at low impedance and are thus tolerant of the effects of wiring lengths. Cables of up to 30 m (100 feet) may be attached to any of the module outputs.

ISSUE 10: 9-1-75 CH. 100 3892 100% WERE 100% MADE IN U.S.A. 100%
 ISSUE 9: 3-26-74 CH. 100 3892 100% WERE 100% MADE IN U.S.A. 100%
 ISSUE 8: 11/3/74 CH. 100 3892 100% WERE 100% MADE IN U.S.A. 100%
 ISSUE 7: 6-10-73 CH. 100 3892 100% WERE 100% MADE IN U.S.A. 100%
 ISSUE 6: 4/1/72 CH. 100 3892 100% WERE 100% MADE IN U.S.A. 100%
 ISSUE 5: 10/4/71 CH. 100 3892 100% WERE 100% MADE IN U.S.A. 100%
 ISSUE 4: 10/4/71 CH. 100 3892 100% WERE 100% MADE IN U.S.A. 100%
 ISSUE 3: 10/4/71 CH. 100 3892 100% WERE 100% MADE IN U.S.A. 100%
 ISSUE 2: 2/25/71 CH. 100 3892 100% WERE 100% MADE IN U.S.A. 100%
 ISSUE 1: 2/25/71 CH. 100 3892 100% WERE 100% MADE IN U.S.A. 100%

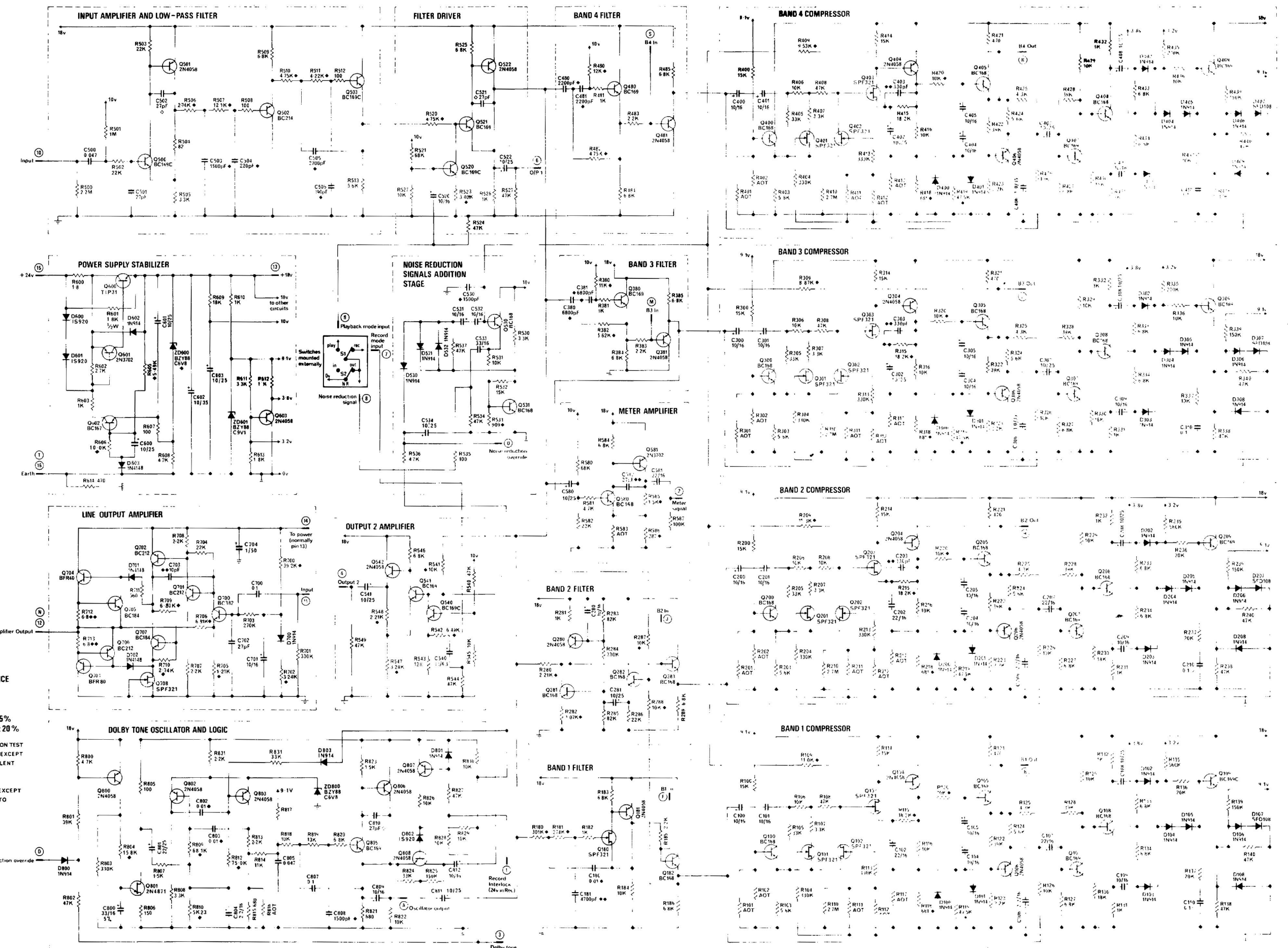

COMPONENT TOLERANCE
 • ±1%
 •• ±2%
 ◊ ±10%
 ALL OTHER RESISTORS ±5%
 ALL OTHER CAPACITORS ±20%
 AOT RESISTORS ADJUSTED ON TEST
 ALL NPN TRANSISTORS EXCEPT
 Q500 & Q704 ARE EQUIVALENT
 TO BC141LC.
 ALL PNP TRANSISTORS EXCEPT
 Q703 ARE EQUIVALENT TO
 BC416LC.

Dolby tone on-off
 Connect to 0v to operate

SECTION 11
INTERFACE SERVICING

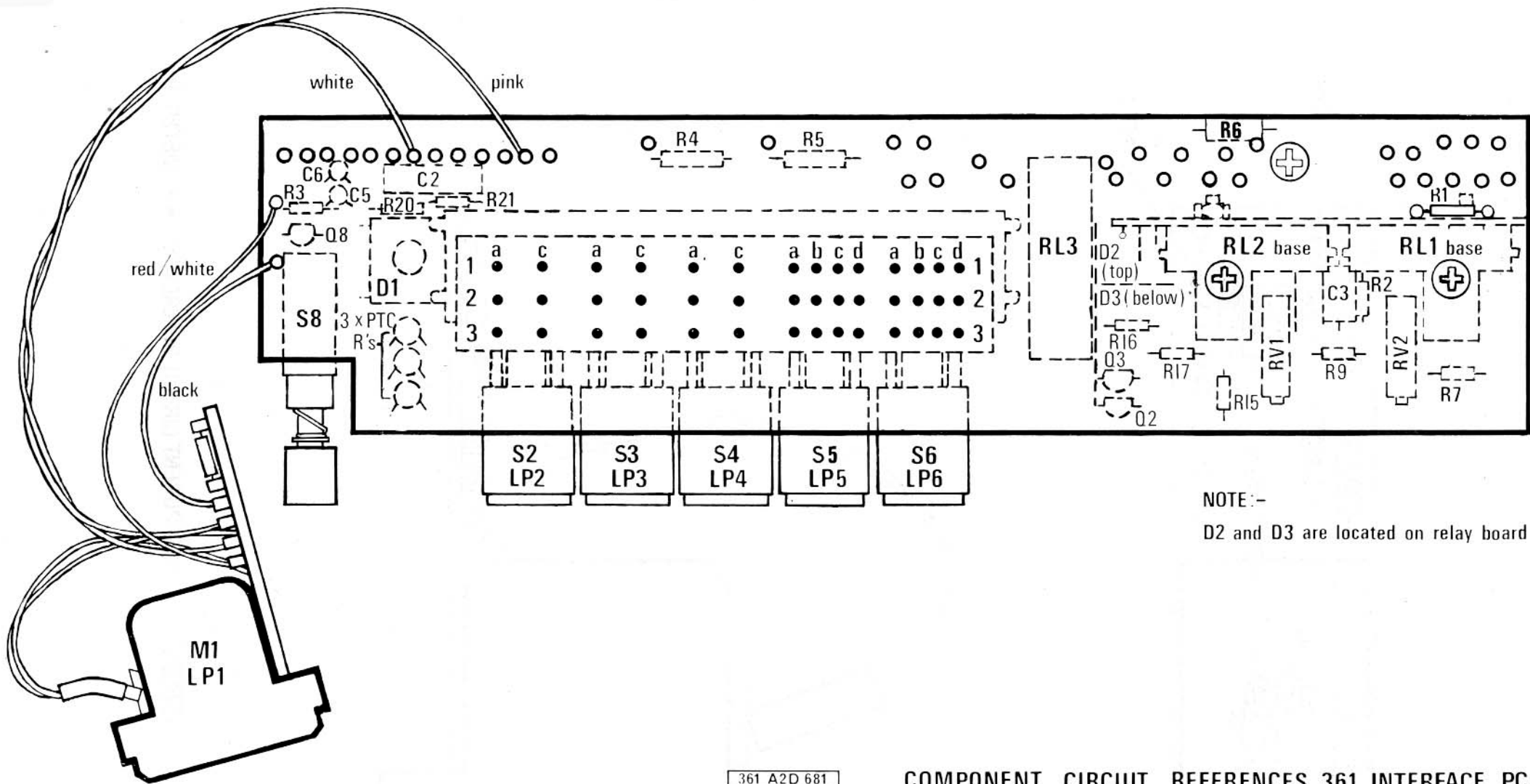

NOTE:-
D2 and D3 are located on relay board

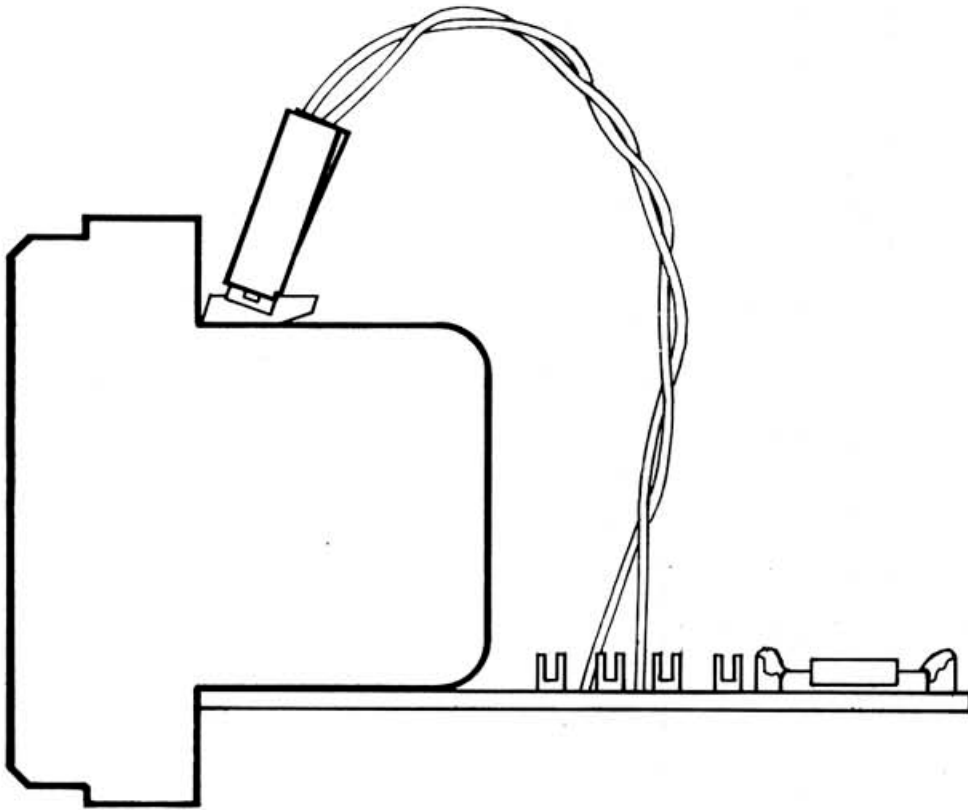
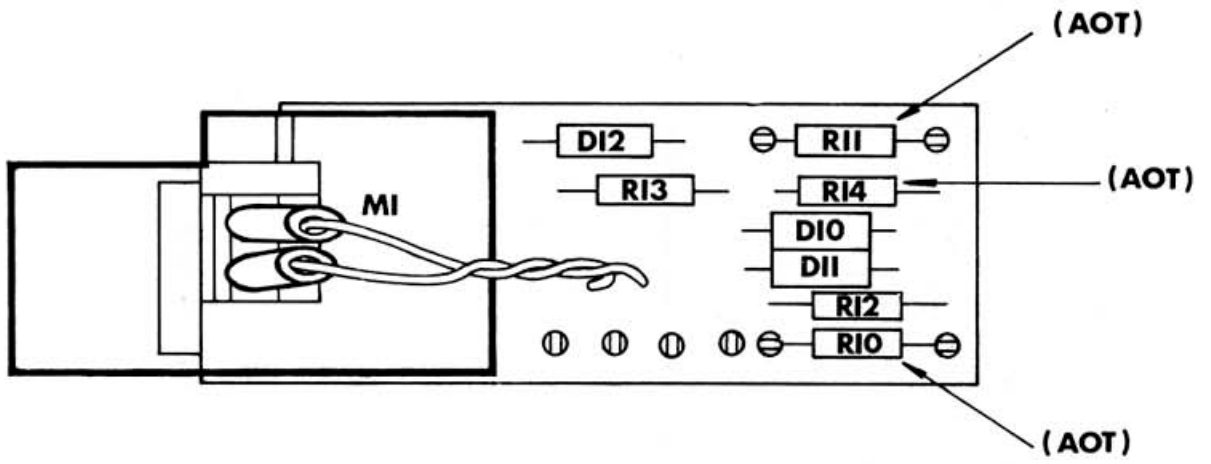

A2D 660/1

COMPONENT CIRCUIT REFERENCES — METER PC

6 SCREWS AND WASHERS
SECURE COVER TO UNIT

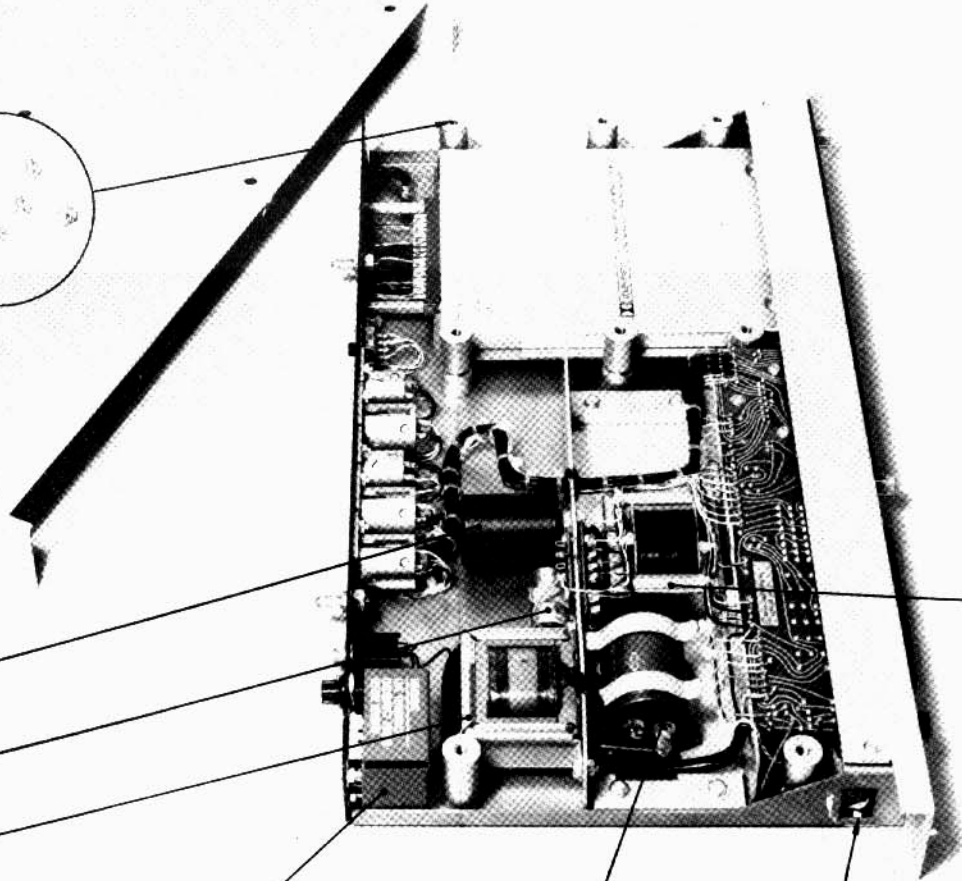
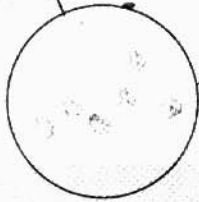

INPUT TRANSFORMER (T2)

OUTPUT CAPACITOR (C4)

POWER TRANSFORMER (T1)

OUTPUT TRANSFORMER (T3)

A.C. POWER COVER MAY BE
REMOVED AFTER RELEASING 2 SCREWS
ON UNDERSIDE OF UNIT.

SMOOTHING CAPACITOR (C1)
MAY BE CHANGED WITHOUT REMOVAL
OF RETAINING CLIPS.

METER BULB MAY BE
CHANGED THROUGH APERTURE
IN SIDE OF UNIT.

NOISE REDUCTION MODULE CAT.No.22
REMOVABLE FROM FRONT OF UNIT AS SHOWN.

ACCESS PLATE MAY BE REMOVED
AFTER RELEASING 2 CAPTIVE SCREWS,
GIVING ACCESS TO NOISE REDUCTION
MODULE AND RELAYS.

RELAYS MAY BE REMOVED
FROM FRONT OF UNIT WITHOUT
PRIOR REMOVAL OF INTERFACE
CHASSIS. MODEL 361 ONLY

METHOD OF INTERFACE CHASSIS REMOVAL

THE INTERFACE CHASSIS AND METER ASSEMBLY CAN BE
SWUNG OVER AND BACKWARDS TO CLEAR OF UNIT
AS SHOWN BY USING THE FOLLOWING PROCEDURE :

1. REMOVE 4 FIXING SCREWS AND WASHERS FROM INTERFACE CHASSIS.
2. SLIDE INTERFACE CHASSIS TOWARDS REAR OF UNIT TO EXPOSE **METER RETAINER**
AND TO ALLOW PUSHBUTTON SWITCHES TO CLEAR THE FRONT PANEL. AFTER REMOVAL OF
METER RETAINER, WITH SCREW AND WASHER, THE INTERFACE CHASSIS AND METER ASSEMBLY
ARE BOTH FREE.

GENERAL SERVICING ACCESS — 330 and 360 Series
Drg.No. AOD 433

© Dolby Laboratories Inc 1971

SECTION 12

SERVICING

CAT. NO. 22 NOISE REDUCTION MODULE

12.1 Introduction

Module exchange is the easiest and most reliable method of repair of the Cat. No. 22 Noise Reduction Module (NRM). However, for situations in which this is not practical, this section provides some basic guidance in user-servicing.

The NRM has been designed for accuracy, reliability, and long life. The individual circuits operate well below their dissipation limits, and close tolerance high stability components ensure repeatability and accuracy of system parameters. There is no need for adjustment of the printed circuit card; the critical parts of the circuit are pre-adjusted during manufacture with fixed-value selected components, using custom-designed test equipment and procedures.

Routine maintenance is confined to verification of the system performance. Repair is usually and most practically achieved by module interchange; faulty modules are then exchanged by local distributors or Dolby Laboratories offices. All modules are guaranteed by Dolby Laboratories for a period of one year from receipt by the customer, the guarantee including freight charges. Subject to the particular customs formalities of the customer's country, the repair will usually be effected on a replacement-basis, with a new or factory-tested module, ensuring that studio inconvenience is kept to a minimum.

12.2 Cat. 35 NRM Test Set

The Cat. No. 35 Test Set (Section 13) is designed for the rapid testing and verification of NRM performance. Needing no external test equipment, the Test Set checks all major functions of the NRM in less than a minute using an internal GO/NO GO meter. More sophisticated tests can also be carried out by the use of external test sources and measuring requirement. Terminals are provided which allow the use of an oscilloscope and ac and dc meters to check points monitored by the tester. This feature allows the circuit area of many faults to be identified quickly. While most troubleshooting and repair work can be achieved by the use of the internal oscillator of the Cat. No. 22, the Test Set also provides terminals and a switch for the use of an external oscillator when necessary.

12.3 Fault Repair

Faults can be categorized into three types. The first type is that of complete failure, which will usually involve a single component in a particular section of the circuit. Such faults are readily traceable, and in general repairs can be made by substitution of a new component.

The second type of fault is a partial, rather than complete, failure. While this may be more difficult to diagnose than the first type, the failure, as before, will usually concern only a single component.

The third and most difficult fault is the intermittent one. It may be difficult to provoke the fault on the test bench, but it will usually yield to one or more of the following factors: heat, cold, humidity, jolts, vibration, or time. Usually only a single component will be involved.

On modules above serial number 2400, an epoxy covering is provided on the top printed circuit tracks; this greatly diminishes the possibility of shorts between the tracks and resistors crossing the tracks. Therefore, even though the resistor bodies are themselves well insulated, the probability of top track shorts is greater on the non-covered boards prior to serial number 2400. This fact should be borne in mind during troubleshooting.

DC voltages are perhaps the best clue to malfunctions, and at the end of this section there is a table showing the principle voltages in the module. The circuit diagram (rear of Section 10) indicates the component tolerances which must be used in all cases of component replacement.

Any fault which involves replacing a selected component, such as the adjust-on-test (AOT) resistors, a component in the +9 volt regulator, or any of the compressor field effect transistors, is not repairable by the user. These components are in general those which determine the Dolby A-type noise reduction characteristic, and are set up to a high degree of accuracy at the factory using specialized test techniques and apparatus. An attempted user repair may compromise the performance of the unit, and all such failures should be returned to Dolby Laboratories or one of its distributors for exchange.

12.4 NRM Test Set Voltage Measurements

It is possible to identify the defective circuit fairly readily by the use of the NRM Test Set even before the module covers are removed. The main ac characteristics can be checked by the use of the internal oscillator and meter, as well as by the test points on the rear of the NRM Tester. Similarly, a number of significant dc measurements can be made using the NRM test points.

For the tests, the Cat. No. 22 module should be plugged into the NRM Tester. The Test Extender should be plugged into the 360 Series or other unit supplying power, and the cable connector should be plugged into the NRM Tester. In the tests, the pin connections and ac and dc voltages brought out from the Cat. No. 22 module to the test point on the rear of the NRM Tester are given in parentheses.

1. In the 24 V position of S1, the ripple on the incoming rough dc supply is checked (pin 15, 600 mV ac maximum, 20-28 V dc).
2. In the 18 V position of S1, the ripple and noise on the output of the module voltage regulator are checked (pin 13, 400 uV ac maximum, 100 kHz bandwidth, 17.5 - 18.5 V dc).
3. In the OSC position of S1, the output of the module oscillator is checked (pin A, 290 - 310 mV ac, 0 V dc). In this position the signal from pin A is also amplified in the NRM Tester to 1.85 V ac, 0 V dc, at connector JF1 and is used to check the calibration of level setting meters (Dolby Level, 185 nWb/m). When the DIN CHECK button is pressed, the signal from pin A is amplified to 3.2 V at JF1 (corresponding to 320 nWb/m).
4. In the OUT 1 position of S1, the signal from the module oscillator (pin A) is fed into the module input (pin 10), and the main-path signal circuit is checked at Output 1 (pin 6, 290 - 310 mV ac, 0 V dc), which follows the playback noise reduction signal combination point.
5. In the METER AMP position of S1, the signal from the module oscillator (pin A) is fed into the module input (pin 10), and the output of the meter amplifier is checked (pin 2, 1.8 - 1.9 V ac, 0 V dc).
6. In the OUT 2 position of S1, the signal from the module oscillator (pin A) is fed into the module input (pin 10), and the main-path signal circuit is checked at Output 2 (pin 4, 480 - 520 mV ac, 0 V dc), which follows the record noise reduction signal combination point.
7. In the DOLBY TONE position of S1, the module oscillator is FM modulated to produce the Dolby Tone, the electronic switch Q808 is energized, and the signal at Output 2 is checked (pin 4, 480 - 520 mV ac, 0 V dc).
8. In the LINE AMP position of S1, the signal from the module oscillator (pin A) is fed into the line amplifier input (pin 11) and the output of the line amplifier is checked (pins 12, N; 1.9 - 2.1 V ac, 8 - 10 V dc).
9. For the compressor tests, switch S1 is set at COMPRESSORS. In this position, the signal from the module oscillator (pin A) is attenuated to 2 mV, 10 mV, and 50 mV for the GAIN, LAW 1, and LAW 2 tests, respectively (S2). The attenuated signal is fed into the input of the compressor selected by S2 (pins, F, J, M, and S for bands 1 - 4, respectively). The outputs of the compressors are checked as follows (pins B, H, L, and R for bands 1 - 4, respectively):

- A. GAIN, 16 - 18 mV ac, 6 - 8 V dc.
- B. LAW 1, 55 - 65 mV ac, 6 - 8 V dc.
- C. LAW 2, 67 - 77 mV ac, 6 - 8 V dc.

10. In the RECORD position of S1, the module is connected in the record mode (pin 8 connected to pin 7), and a signal from the module oscillator (pin A) is attenuated to 3 mV and fed into the module input (pin 10). The output of the module is checked at Output 2 (pin 4, 15 - 17 mV ac, 0 V dc).
11. In the NR OUT position of S1, the noise reduction signal is disabled and a signal from the module oscillator (pin A) is attenuated to 3 mV and fed into the module input (pin 10). The output of the module is checked at Output 2 (pin 4, 4.8 - 5.2 mV, 0 V dc: i. e. 9.5 - 10.5 dB lower than in test 10 above).
12. In the PLAY position of S1, the module is connected in the playback mode (pin 8 connected to pin 9) and a signal from the module oscillator (pin A) is attenuated to 3 mV and fed into the module input (pin 10). The output of the module is checked at Output 2 (pin 4, 1.5 - 1.7 mV ac, 0 V dc; i. e. 9.5 - 10.5 dB lower than in test 11 above).

12.5 Comprehensive dc Voltage Measurements

Once the general circuit area of the fault is given by the tests in Section 12.4 above, the module covers should be removed for further investigations.

Detailed circuit tests can be made of the suspected area by referring to the voltage tables given on pages 12.7 to 12.9, the test point location drawing on page 12.6, and the component location drawing on page 12.10.

The NRM Tester can be used on its side for this application, allowing access to both top and bottom of the NRM.

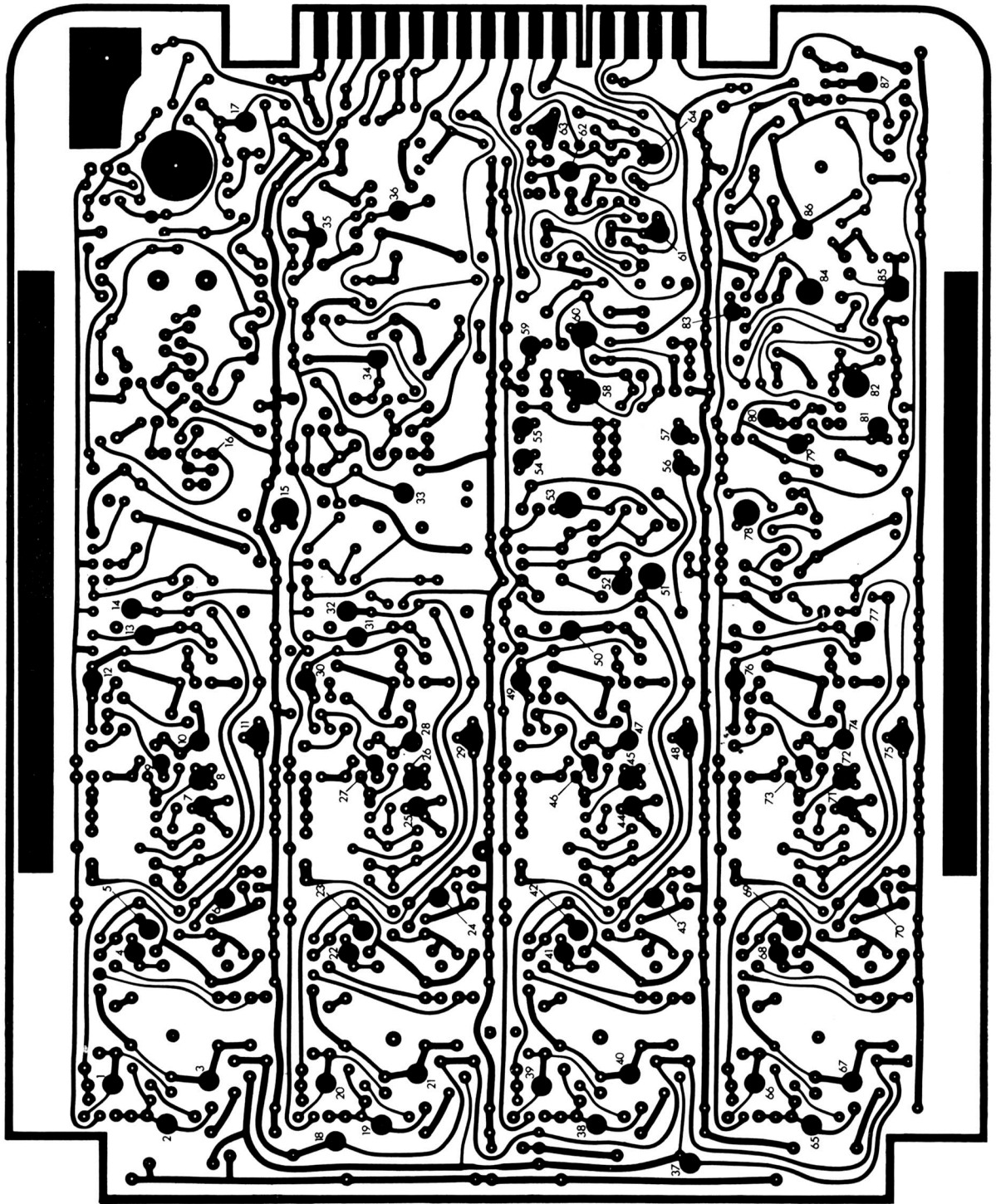

Test Points

1-17

18-36

37-64

65-87

CAT No. 22 TEST POINT LOCATIONS

Drq. No. AIPM 747

© Dolby Laboratories Inc 1972

Voltage Tables

1. Power Supply Voltages

- Note: 1. Pin number are circled.
2. dc voltage tolerance ± 0.5 V except where stated.

| Measuring point | Testpad/Pin No. | dc voltage | max ac (rms) |
|-----------------------|-----------------|----------------|--------------|
| Incoming rough supply | ⑮ | 24 (± 4) | 600 mV |
| +18 v line | ⑬ | 18 | 400 uV |
| +10 v line | 15 | 10.2 | - |
| +9.1 v line | 84 | 9.1 | - |
| +3.2 v line | 37 | 3.2 | - |
| +3.8 v line | 18 | 3.8 | - |

2. Main signal path

Note: Collector designated c, emitter designated e.

| Measuring point | Testpad/Pin No. | dc voltage | ac voltage with Cat. No. 35 |
|-----------------|-----------------|------------|--------------------------------|
| Q503 e | 34 | 9.6 | Out 1 290-310 mV |
| Q522 c | 33 | 8.1 | Out 1 290-310 mV |
| Q542 | 62 | 10.0 | Out 1 480-520 mV |
| Q581 c | 63 | 10.5 | Out 1 1.8-1.9 v |
| Q700 e | 16 | 1.4 | Line Amp 290-310 mV |
| Line Amp Output | ⑫ or ⑮ | 9.0 | Line Amp 1.9-2.1 v |

3. Noise Reduction Path

| Measuring point | Testpad/Pin No. | dc voltage | ac voltage with Cat. No. 35 |
|-----------------|-----------------|------------|---|
| Q182 e | 78 | 10.5 | |
| Q283 e | 51 | 6.8 | |
| Q282 e | 52 | 10.0 | |
| Q381 e | 32 | 10.2 | |
| Q481 e | 14 | 10.2 | |
| Q100 e | 76 | 5.9 (1) | |
| Q200 e | 49 | 5.9 (1) | |
| Q300 e | 30 | 5.9 (1) | |
| Q400 e | 12 | 5.9 (1) | |
| Q105 e | ⓑ | 6.8 | } Gain 16-18 mV Law 1 55-65 mV Law 2 67-77 mV |
| Q205 e | ⓓ | 6.8 | |
| Q305 e | Ⓛ | 6.8 | |
| Q405 e | Ⓡ | 6.8 | |
| Q108 c | 69 | 14.3 | |
| Q208 c | 42 | 14.3 | |
| Q308 c | 23 | 14.3 | |
| Q408 c | 5 | 14.3 | |
| Q109 e | 65 | 3.2 (2) | |
| Q209 e | 38 | 3.2 (2) | |
| Q309 e | 19 | 3.2 (2) | |
| Q409 e | 2 | 3.2 (2) | |
| Q106 e | 70 | 1.0 | |
| Q206 e | 43 | 1.0 | |
| Q306 e | 24 | 1.0 | |
| Q406 e | 6 | 1.0 | |
| C106/R140 Gain | 75 | 3.1 | |
| Law 1 | 75 | 3.5 | |
| Law 2 | 75 | 3.7 | |
| C206/R240 Gain | 48 | 3.1 | |
| Law 1 | 48 | 3.5 | |
| Law 2 | 48 | 3.7 | |
| C305/R340 Gain | 29 | 3.1 | |
| Law 1 | 29 | 3.5 | |
| Law 2 | 29 | 3.7 | |
| C406/R440 Gain | 11 | 3.1 | |
| Law 1 | 11 | 3.5 | |
| Law 2 | 11 | 3.7 | |
| Q530 e | 59 | 6.6 | |
| Q531 c | 60 | 3.0 | |

Note: (1) Prior to Serial No. 1500, tolerance is ± 2 v
(2) High input impedance voltmeter must be used

4. Oscillator and Logic

| Measuring point | Testpad/Pin No. | dc voltage | Notes |
|-----------------|-----------------|------------|---|
| Q803 e | 83 | 6.8 | |
| Q805 e | 86 | 3.6 | Normal operation in installation, or Cat. 35 'Noise' modes. |
| Q805 e | 86 | 3.0 | D. T. button pressed, or all Cat. 35 modes except 'Noise'. |
| D. T. line | ③ | 13.5 ±2 | Normal operation in installation. |
| D. T. line | ③ | 0 | D. T. button pressed, or all Cat. 35 modes except 'Noise'. |
| Q807 c | 87 | 17.9 | Installation Play mode or all Cat. 35 modes except 'Dolby Tone'. |
| Q807 c | 87 | 1.7 | Cat. 35 'Dolby Tone' mode. Installation Record Mode or Cat. 35 'Dolby Tone' mode. |
| NR override | ⓓ | 13.5 ±2 | In installation, and Cat. 35 'Dolby Tone' mode. |
| NR override | ⓓ | 18 | In Cat. 35, except 'Dolby Tone' mode. |

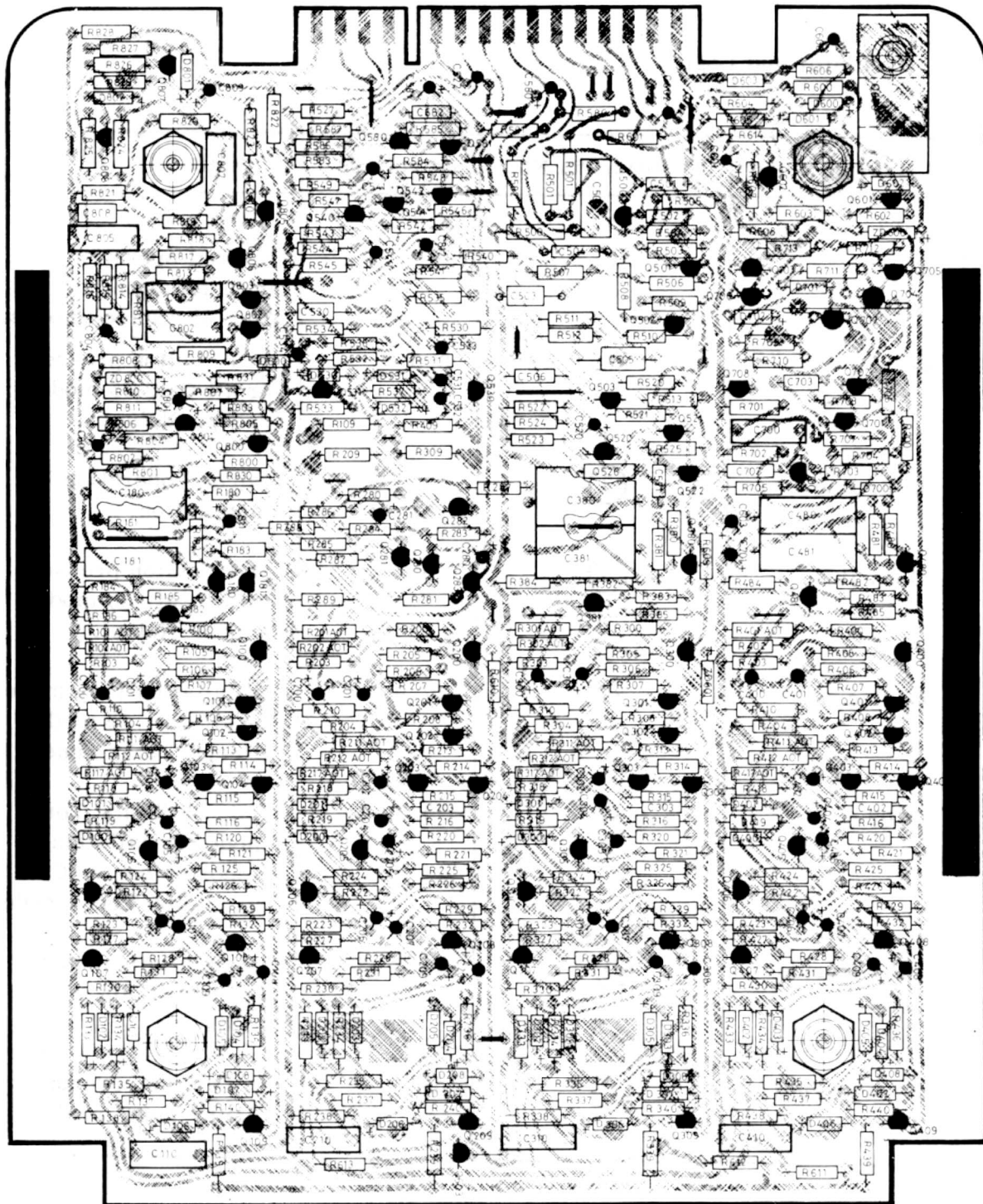

Issue 6-1

Cat No 22 COMPONENT LOCATION

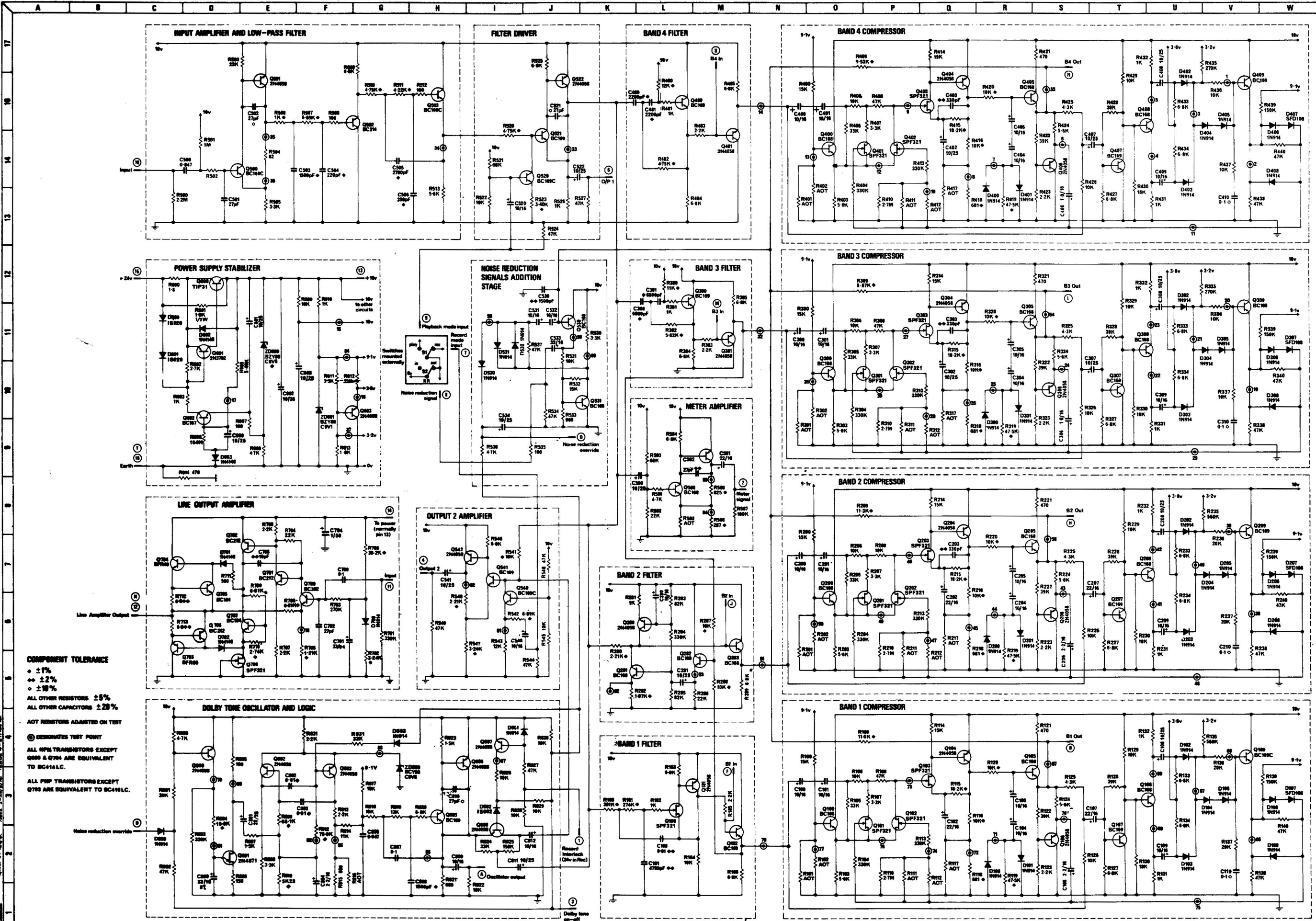

COMPONENT TOLERANCE
 • ±1%
 • ±2%
 • ±5%
 ALL OTHER RESISTORS ±5%
 ALL OTHER CAPACITORS ±20%
 AOT RESISTORS ADJUSTED ON TEST
 ⊙ DESIGNATES TEST POINT
 ALL NPN TRANSISTORS EXCEPT Q690 & Q794 ARE EQUIVALENT TO BC141LC.
 ALL PNP TRANSISTORS EXCEPT Q785 ARE EQUIVALENT TO BC410LC.

SECTION 13**CAT. NO. 35 NRM TEST SET**



DOLBY LABORATORIES INC

A-TYPE NOISE REDUCTION SYSTEM

OPERATING INSTRUCTIONS

NRM Test Set, Cat. No. 35

NRM Tester, Cat. No. 35A

Test Extender, Cat. No. 35B

The NRM Test Set comprises the Noise Reduction Module Tester (Cat. No. 35A) and the Test Extender (Cat. No. 35B). The Test Set is designed to test all major functions of the Noise Reduction Module (Cat. No. 22), to check the ripple level of the rough d. c. supply which powers the module, and to verify the accuracy of level setting meters used in the equipment in which the module is installed.

Testing of Noise Reduction Modules

1. Brief operating instructions are given on the front of the Test Extender. More detailed instructions and explanations are provided below.
2. Remove the Cat. No. 22 Noise Reduction Module to be tested. In 360 Series units, access to the module is provided by removal of the front cover plate.
3. Plug the module into the connector on the NRM Tester.
4. Plug the Test Extender into the connector from which the module was removed.
5. Plug the cable connector from the Test Extender into connector JF1 on the NRM Tester. This provides power to the NRM Tester and the module under test. The cable also provides a return signal from the NRM Tester for meter calibration purposes.
6. For completely self-contained operation of the NRM Tester, set the oscillator switch on the rear of the tester to the internal position. In this mode the signal used in the various tests is provided by the internal Dolby Tone oscillator in the module.
7. To test the various circuit functions of the module, rotate the switch S1 progressively clockwise, beginning at 24V NOISE. Stop at COMPRESSOR, and rotate switch S2 through all of its positions, beginning at GAIN, BAND 1. Following the compressor tests,

proceed with switching S1 clockwise. The meter should read TEST (or the green LED should be on) in all positions except NOISE. The two noise positions should provide meter readings in the band marked NOISE (in this case, the green LED also should be on).

NOTE: Latest models of the Cat. No. 35 use an LED display in place of the meter, providing greater reliability and improved accuracy. All tests are satisfactory if the green LED is on; the red LED indicates a fault condition. The yellow LED shows a condition analogous to the meter pointer being exactly on the tolerance limits, and shows that the module almost certainly can be used with satisfactory results, but should be returned for overhaul as soon as practical. Note that if the amber LED is on for all tests (equivalent to all test results being marginal), this probably signifies a low or high Dolby test tone oscillator and no malfunction in the Dolby circuit itself. The green LED covers a range ± 0.5 dB about the desired value, and the yellow LED covers a further ± 0.5 dB. The black area on the meter version also indicated a ± 0.5 dB range about nominal value.

Testing of Meters

1. To check the calibration of level setting meters, set switch S1 to OSC position. 360 Series meters or other meters associated with the module should read 185 nWb/m (Dolby Level).
2. On 360 Series units the calibration of the DIN mark on the meter can be checked by pressing the DIN CHECK button (OSC position of S1) on the NRM Tester. The 360 Series meter should be read from directly in front; parallax should not be corrected for when making DIN readings.

Details of Tests

In the tests, the pin connections and a. c. and d. c. voltages brought out from the Cat. No. 22 module to the test point on the rear of the NRM Tester are given in parentheses.

1. In the 24V position of S1, the ripple on the income rough d. c. supply is checked (pin 15, 600 mV a. c. maximum, 20-28V d. c.).
2. In the 18V position of S1, the ripple and noise on the output of the module voltage regulator are checked (pin 13, 400 uV a. c. maximum, 17.7-18.5V d. c.).
3. In the OSC position of S1, the output of the module oscillator is checked (pin A, 290-310 mV a. c., 0V d. c.). In this position the

signal from pin A is also amplified in the NRM Tester to 1.85V a. c. 0V d. c. , at connector JF1 and is used to check the calibration of level setting meters (Dolby Level, 185 nWb/m). When the DIN CHECK button is pressed, the signal from pin A is amplified to 3.2V at JF1 (corresponding to 320nWb/m). (The LED display is switched off for this test).

4. In the OUT 1 position of S1, the signal from the module oscillator (pin A) is fed into the module input (pin 10), and the main-path signal circuit is checked at Output 1 (pin 6, 290-310 mV a. c. , 0V d. c.), which follows the playback noise reduction signal combination point.
5. In the METER AMP position of S1, the signal from the module oscillator (pin A) is fed into the module input (pin 10), and the output of the meter amplifier is checked (pin 2, 1.8-1.9V a. c. , 0V d. c.).
6. In the OUT 2 position of S1, the signal from the module oscillator (pin A) is fed into the module input (pin 10), and the main-path signal circuit is checked at Output 2 (pin 4, 480-520 mV a. c. , 0V d. c.), which follows the record noise reduction signal combination point.
7. In the DOLBY TONE position of S1, the module oscillator is FM modulated to produce the Dolby Tone, the electronic switch Q808 is energized, and the signal at Output 2 is checked (pin 4, 480-520 mV a. c. , 0V d. c.).
8. In the LINE AMP position of S1, the signal from the module oscillator (pin A) is fed into the line amplifier input (pin 11), and the output of the line amplifier is checked (pins 12, N; 1.9-2.1V a. c. , 8-10 d. c.).
9. For the compressor tests, switch S1 is set at COMPRESSORS. In this position, the signal from the module oscillator (pin A) is attenuated to 2 mV, 10 mV and 40 mV for the GAIN, LAW 1, and LAW 2 tests, respectively (S2). The attenuated signal is fed into the input of the compressor selected by S2 (pins F, J, M and S for bands 1-4, respectively). The outputs of the compressors are checked as follows (pins B, H, L and R for bands 1-4, respectively):
 - A. GAIN, 16 - 18 mV a. c. , 6 - 8V d. c.
 - B. LAW 1, 55 - 63 mV a. c. , 6 - 8V d. c.
 - C. LAW 2, 67 - 77 mV a. c. , 6 - 8V d. c.

10. In the RECORD position of S1, the module is connected in the record mode (pin 8 connected to pin 7), and a signal from the module oscillator (pin A) is attenuated to 3 mV and fed into the module input (pin 10). The output of the module is checked at Output 2 (pin 4, 15-17 mV a. c. , 0V d. c.).
11. In the NR OUT position of S1, the noise reduction signal is disabled and a signal from the module oscillator (pin A) is attenuated to 3 mV and fed into the module input (pin 10). The output of the module is checked at Output 2 (pin 4, 4.8-5.2 mV a. c. , 0V d. c. ; i. e. 9.5-10.5 dB lower than in test 10 above).
12. In the PLAY position of S1, the module is connected in the playback mode (pin 8 connected to pin 9) and a signal from the module oscillator (pin A) is attenuated to 3 mV and fed into the module input (pin 10). The output of the module is checked at Output 2 (pin 4, 1.5-1.7 mV a. c. , 0V d. c. ; i. e. 9.5-10.5 dB lower than in test 11 above).

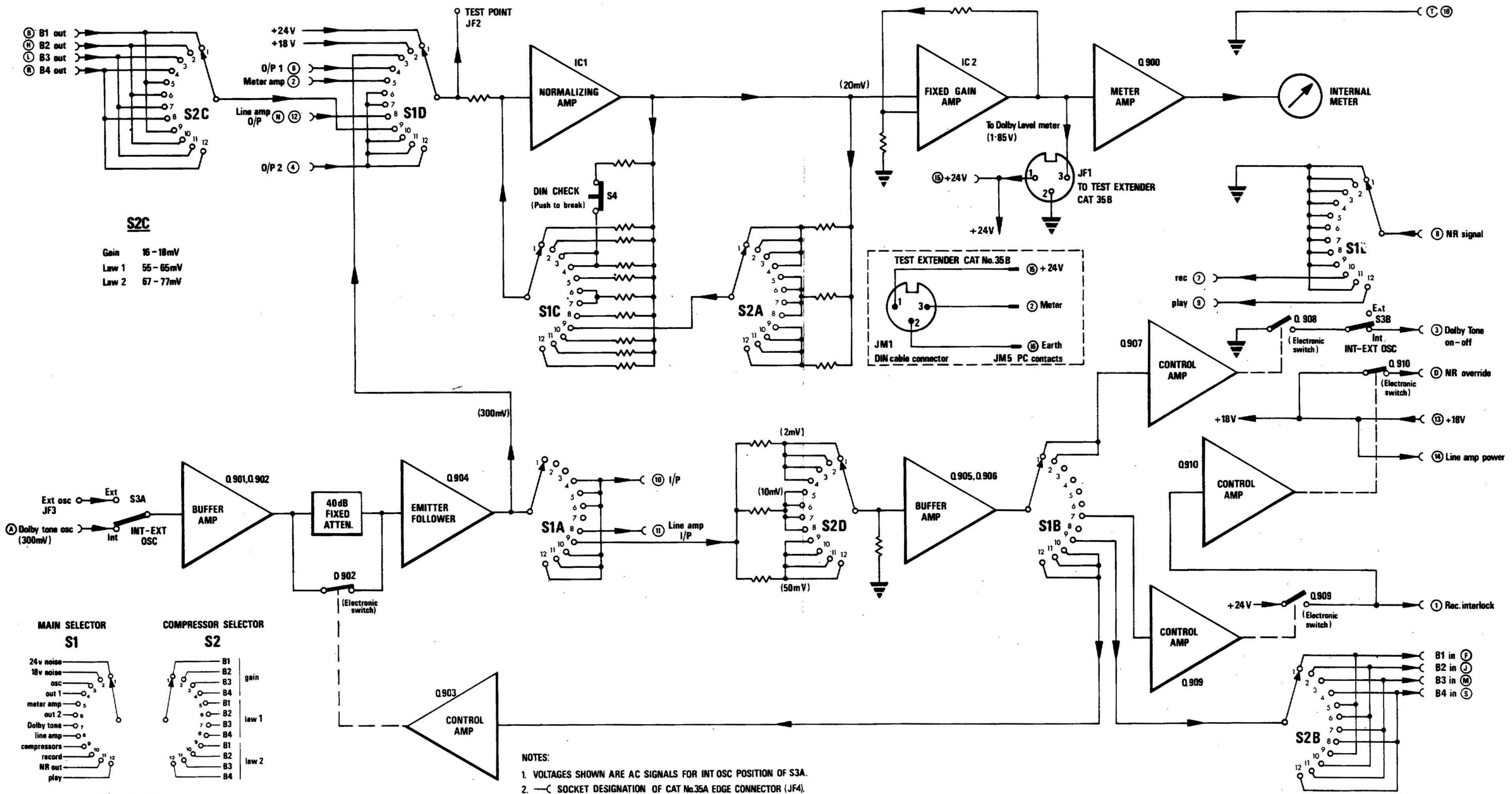

S2C

| | |
|-------|-----------|
| Gain | 16 - 18mV |
| Law 1 | 55 - 65mV |
| Law 2 | 67 - 77mV |

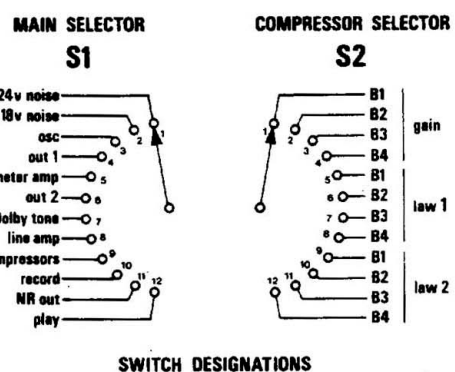

NOTES:

- VOLTAGES SHOWN ARE AC SIGNALS FOR INT OSC POSITION OF S3A.
- SOCKET DESIGNATION OF CAT No.35A EDGE CONNECTOR (JF4). MATES WITH CAT No.22 NOISE REDUCTION MODULE.
- PC CONTACTS ON CAT No.35B (JM5). MATES WITH CHASSIS EDGE CONNECTOR IN CAT No.22 INSTALLATION.

NRM TEST SET CAT No. 35 BLOCK DIAGRAM

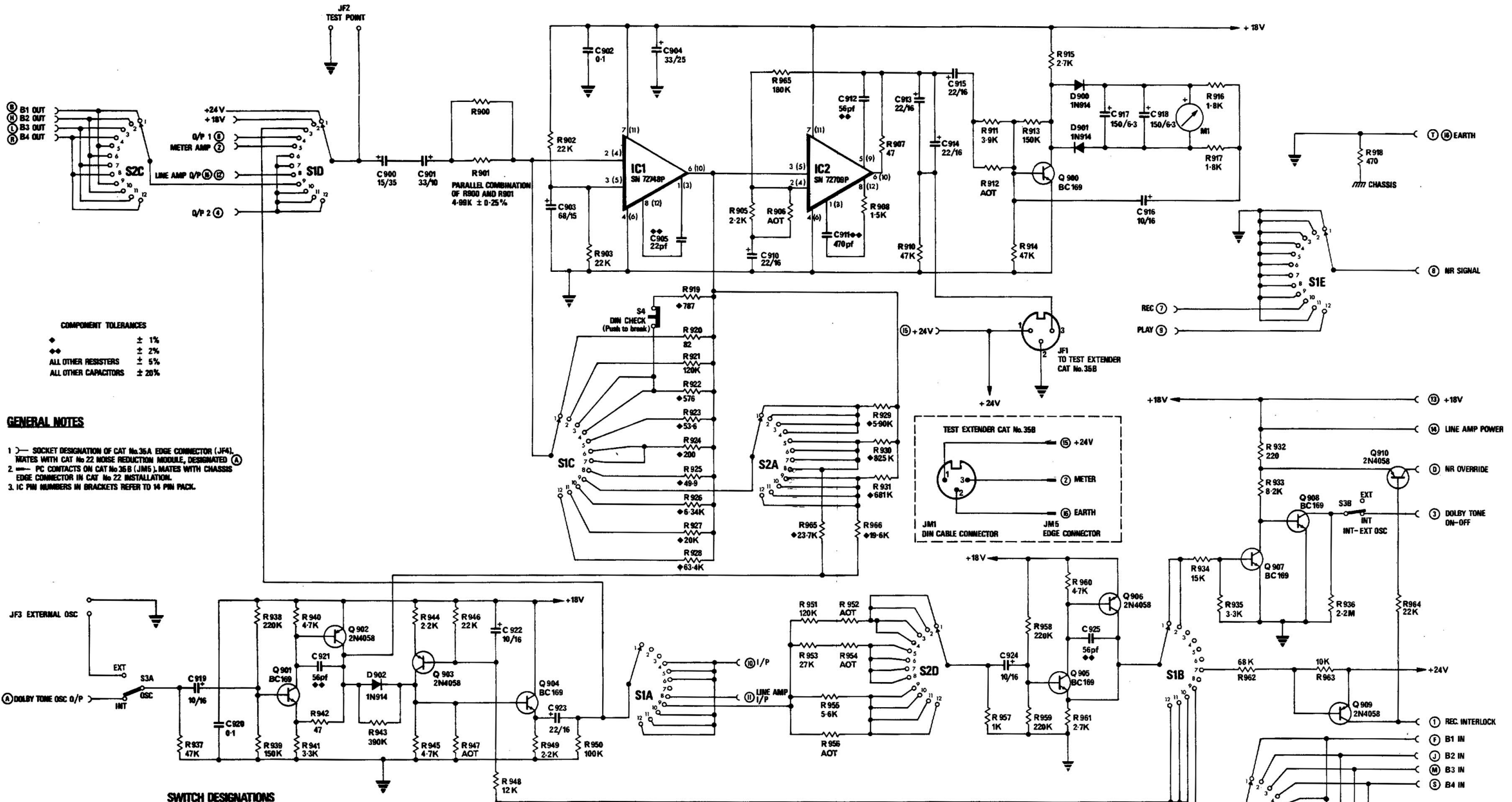

COMPONENT TOLERANCES

- ± 1%
- ± 2%
- ± 5%
- ± 20%

◆ ± 1%
◆± ± 2%
◆± ± 5%
◆± ± 20%

GENERAL NOTES

1. SOCKET DESIGNATION OF CAT No. 35A EDGE CONNECTOR (JF4), MATES WITH CAT No. 22 NOISE REDUCTION MODULE, DESIGNATED (A).
2. PC CONTACTS ON CAT No. 35B (JM5), MATES WITH CHASSIS EDGE CONNECTOR IN CAT No. 22 INSTALLATION.
3. IC PIN NUMBERS IN BRACKETS REFER TO 14 PIN PACK.

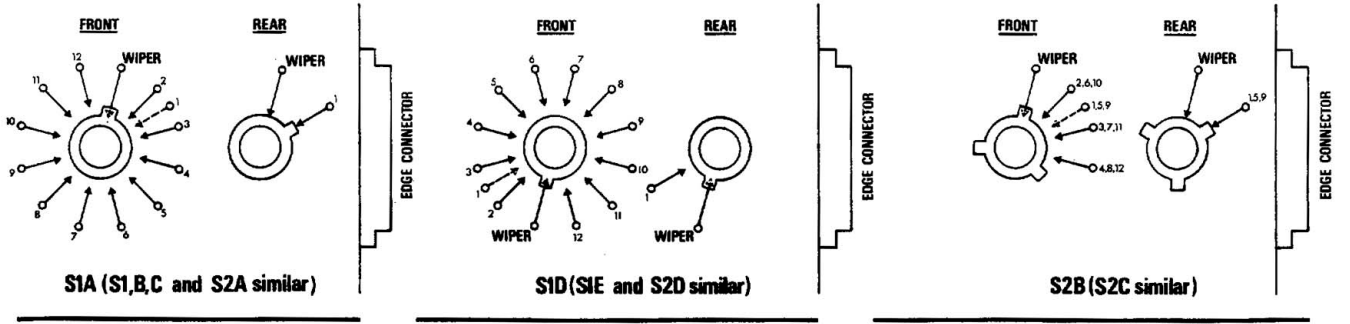
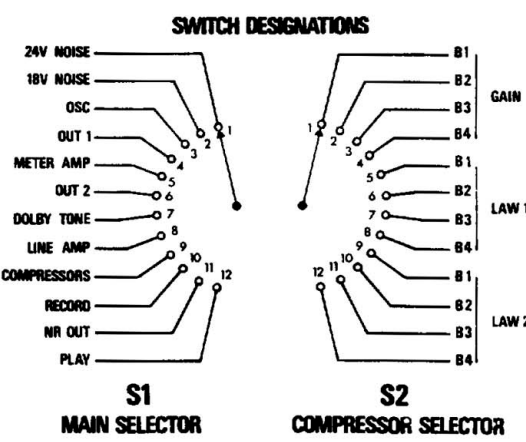

SWITCH NOTES

1. ALL WAFERS ARE VIEWED FROM THE KNOB END.
2. WAFERS ARE SHOWN RELATIVE TO EDGE CONNECTORS.
3. WAFERS S1B & D HAVE NON-SHORTING BLADES. ALL OTHER WAFERS HAVE SHORTING BLADES.
4. WAFERS ARE LETTERED IN ALPHABETICAL ORDER FROM THE KNOB END.