



ELEKTRONIK-
MESS- UND
TONSTUDIOTECHNIK

EMT-FRANZ ^{VG}_{mbH}

Postfach 1520, D-7630 Lahr
Tel. 07825/512, Telex 754319 franz d

Instruction Manual

EMT 240

Reverb Foil



EMT-FRANZ ^{VG}
_{mbH.}

D-763 Lahr 1, Postfach 1520
Tel. 07825/512, Telex 754319 franz d

Nachhallfolie EMT 240 in Verbindung mit STUDER-Mischpulten

Die Firma STUDER hat in ihrem Lieferprogramm für Mischpulte die Nachhalleinheit 1.091.019 mit Fernbedienung für EMT-Nachhallgeräte.

Um alle Bedienungsfunktionen (inklusive Ferneinschalten) dabei steuern zu können, sind an der Nachhallfolie EMT 240 folgende Änderungen durchzuführen:

1. Nach Entfernen der rechten Seitenwand Verbindungsflasche Gehäuse mit + verbinden (s. Bedienungsanleitung S. 14).
2. Nach zusätzlichem Entfernen der Abdeckhaube hinter dem Anschluß Netz und Fernbedienung (Achtung: Netzstecker muß gezogen sein!) sind am 8poligen Anschlußstecker (Pkt. 7) die 3 blauen Kabel abzulöten. Es ist auszumessen, welches der 3 Kabel an Anschluß 5 der Netztrafo-Leiterplatte führt. Dieses ist wieder an den Anschlußstecker (Pkt. 7) anzulöten, die beiden anderen sind freitragend zu verbinden.

Das Ferneinschalten der Nachhalleinheit ist nun vom Pult aus möglich.

EMT 240 Reverb Foil in connection with STUDER Mixing Desks

STUDER supplies within his range of mixing desk modules the Reverb Control Unit 1.091.019.

In order to enable all operations to be remote controlled (inclusive remote power on) the following modifications have to be made in the EMT 240:

1. After removing the right cover plate the ground strap should be connected to + (see page 14 instruction manual).
2. After also removing the small box covering the power and remote line connectors, unsolder the three blue wires from pin 7 of the 8-pole connector. Check by means of an ohm-meter which one of the three wires leads to point 5 of the power-transformer printboard. This one then has to be connected to point 7 again, the other two have to be interconnected and insulated.

The remote power switching of the EMT 240 Reverb Foil is now possible.

Nur stehend transportieren!
TRANSPORT IN UPRIGHT POSITION ONLY!

ACHTUNG!

Das Gerät enthält eine z u s ä t z l i c h e Sturzsicherung, um einer Beschädigung infolge rauher Behandlung durch Sturz oder Stoß auf dem Versandweg vorzubeugen.

Bitte entfernen Sie vor Inbetriebnahme diese Sturzsicherung in der Reihenfolge:

Eine Seitenwand öffnen - Muttern an den unteren Holzklötzen mit dem im Zubehör enthaltenen Schlüssel lockern, bis die Bolzen die Kalotte freigeben - obere, nur eingeklemmte Hölzer seitlich abziehen - untere Hölzer seitlich abziehen.

Die Kalotte muß jetzt in allen Richtungen frei pendeln können.

Falls für Sie gelegentlicher Versand durch Transportunternehmen, wie Bahn, Luftfracht oder Spedition, in Betracht kommt, empfehlen wir in Ihrem Interesse, die Sturzsicherung wieder einzubauen und das Gerät nur in der Originalverpackung zu verschicken.

Bei sachgemäßem Transport in PKW, LKW oder Ü-Wagen sowie schonender Behandlung beim Ein- und Ausladen sind weder diese Sturzsicherung noch Verpackung erforderlich.

ATTENTION!

The unit contains an a d d i t i o n a l protection against shock, in order to prevent any damages caused by shock or other impacts due to rough handling in transit.

Before operation please remove the shock protection in the following sequence:

Open one side of the housing - take the wrench of the accessories and loosen nuts at the lower wooden blocks until the bolts will release the inside housing - take off laterally the squeezed upper blocks - take off laterally the lower blocks.

The inside housing should now swing freely in all directions.

If shipment has to be made by you occasionally via carriers, such as railway, airfreight or forwarding agents, we would recommend in your own interest to re-mount the shock protection and to ship the unit only in its original packing.

The shock protection and the packing is not necessary for transportation by car, truck or Broadcasting Van provided the unit is

You have acquired a precision instrument when you bought the EMT 240 Reverb Foil. It was designed for field use and is therefore made to withstand mechanical shock found under normal operating conditions. Do not subject the

unit to excessive accelerations – treat it with the same care with which you would handle a tape recorder, for example. This will assure that the excellent performance specifications of the EMT 240 will be maintained for some time to come.

Unpacking instructions and preliminary set-up

You have just opened the outer packing case – please read on before you unpack the unit any further.

1. Remove the foam cushions on top of and on the left and right of the inner carton. Check to see that all of the accessories in the plastic covered boards correspond to the list on page 4.
2. Carefully lift out the inside carton. Do not lay the unit on its side under any circumstances!
3. Open inside carton.
4. **ATTENTION!**
The unit contains an additional protection against shock, in order to prevent any damages caused by shock or other impacts due to rough handling in transit.
Before operation please remove the shock protection in the following sequence:
Open one side of the housing – take the wrench of the accessories and loosen nuts at the lower wooden blocks until the bolts will release the inside housing – take off laterally the squeezed upper blocks – take off laterally the lower blocks.
The inside housing should now swing freely in all directions.
If shipment has to be made by you occasionally via carriers, such as railway, airfreight or forwarding agents, we would recommend in your own interest to re-mount the shock protection and to ship the unit only in its original packing.
The shock protection and the packing is not necessary for transportation by car, truck or Broadcasting Van, provided the unit is handled with care during such transportation and when loading and unloading the equipment.
5. Locate unit at desired spot and connect electrically (page 8). Check proper line voltage setting!
Turn unit on. Push the reverberation time button (-) for about 10 seconds. The unit is now ready for operation.
6. Save all packing materials! Re-ship only in the original packing.

**TRANSPORT IN UPRIGHT POSITION
ONLY!**

System make-up and Accessories EMT 240

Reverb Foil for stereo/mono operation, with built-in remote control, but without remote control operating elements; with driver and pick-up amplifier and one set of counter-plugs.

Standard Equipment (included with every delivery)	Ordering number
2 Drive/pick-up amplifiers EMT 262	9 262 000
2 Mating connectors Switchcraft A3F or Cannon XLR 3-11 c (Female)	4 204 062
2 Mating connectors Switchcraft A3M or Cannon XLR 3-12 c (Male)	4 203 067
1 Mating connector female Tuchel T 3055 (remote control)	4 204 012
1 AC cable with Schuko plug (EUROPEAN)	4 240 579
1 AC cable with U.S. AC connector	4 240 580
Fuses and pilot lamps	7 240 091

Special accessories (to be ordered separately)

1 set remote control operating components EMT 240 B	7 140 202
1 Test tape with white noise in third-octave bands for calibrating and checking of EMT 140 and 240 Reverberation Units	EMT 140-T
1 Reverberation time meter (part of EMT 240 B kit)	4 171 008
1 Set of special adjustment and test tools consisting of:	7 240 100
1 Box wrench	4 295 005
1 Screwdriver	4 295 004
1 Optical pick-up coil centering jig	7 240 088
1 Allen wrench	4 295 006
1 End wrench	4 295 007
1-Set screws, nuts and washers	7 240 095

Technical Description

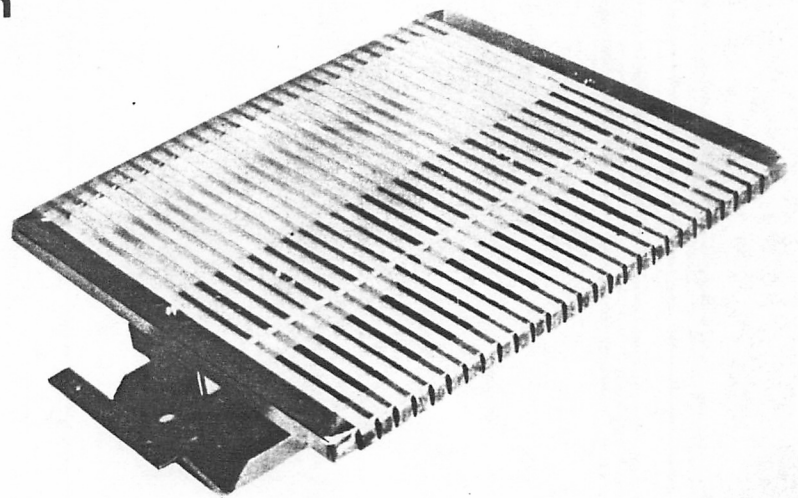

The Reverb Foil EMT 240 is a device for producing reverberation.

The principle involving the use of a flat, tensioned plate for the creation of reverberation, which has been used for the past decades, has been retained in this new device. In the course of technical improvement and the significant reduction in size, the material used in the vibrating plate has also been changed: The EMT 240 Reverb Foil uses an electroplated gold foil of great purity (24 carat "coin gold") with a thickness of only $18\mu\text{m}$ (.00071") and 270×290 mm (10.6"x11.4") size. This foil is mounted in a frame under tension, excited by a driver, and sensed by a pick-up system.

Changing the Reverberation Time

The reverberation time is changed as before by bringing a damping device in close proximity to the foil. A vibrating foil such as this gives off energy to the surrounding air (sound field); by bringing an absorber more or less close to this sound field, energy is removed and the decay is damped to a greater or lesser extent.

This method not only has the advantage of damping all frequencies equally and without erratic behavior (as may occur due to the complex input impedance of a mechanical system when damping is done electrically by changing the impedance of the transducer), but it is also possible, using suitable means, to make this absorption frequency dependent and thereby to compensate the response of the reverberation time. These frequency dependent resistances are produced by openings in the damping plate. The picture shows slots in the actual damping material which serve this purpose. By varying the slot widths and the ratio between slot and damping surface, the required equalization is obtained.

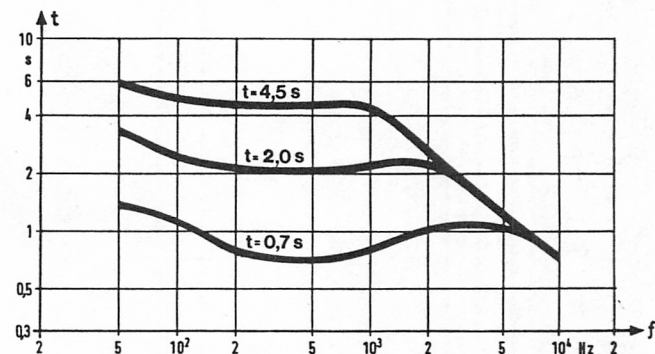

The curves of the reverberation time vs. frequency show the results of the slotted damping plate construction. The very linear response even for longer reverberation times produces a more balanced subjective sound quality.

Remote Reverberation Time Control

The damping plate may be moved by remote control. A complete description, including connection means, is given on page 9.

Drive Transducers

In contrast to the dynamic drive system used in the EMT 140 Reverberation Unit, this unit uses a piezo-ceramic driver. The transducer consists of a thin disk of lead-zirconate-titanate as the active element glued directly to the gold foil. A mass of 1 g is glued to the side of the disk away from the foil. Above the boundary frequency, which is far below the audio range, the mass impedance becomes considerably higher than the bending mode input impedance of the foil, so that this mass may be considered as dynamically stationary at higher frequencies. The electrical connections to the piezo element are via the foil on the one hand and the counter weight on the other. In order to prevent interference from the connection wire, it must be kept very thin ($0.02 \text{ mm} \approx 0.8 \text{ mil}$). In view of the small total mass of the transducer and the resulting minimal torsional moment which the transducer imparts to the foil, no further fastening is needed. This eliminates many problems of a dynamic system such as centering of the coil in the magnet gap and securing it for shipment.

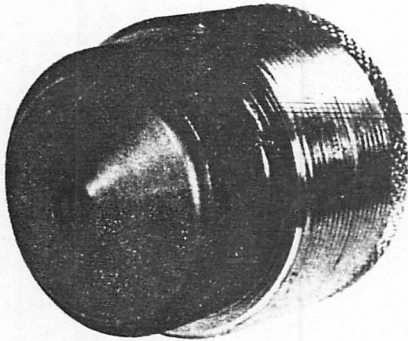

Bending waves of constant excursion amplitude over the frequency range above the boundary frequency are produced when a constant AC voltage is applied.

Pick-up Transducer

A dynamic moving coil system, similar to a dynamic microphone, is used as the pick-up transducer, but with a much smaller coil. The magnet gap is made very large to simplify the alignment of the coil.

The gap flux needed for high transducer sensitivity requires a magnetic material with very high energy density and an iron core with a high degree of saturation induction.

The moving coil with a mass of 4–6 mg is glued to a coil form with a mass of 4 mg. This

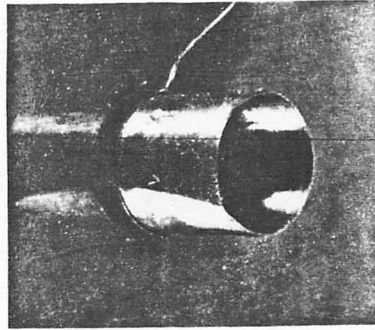

coil form has the shape of a cone with its apex on the foil, to prevent high frequency losses due to integration across a wave length. The mass of the moving system together with the bending mode input impedance of the foil determine the boundary frequency of the transducer which is 100 Hz. For constant excursion amplitude of the foil, this produces a response which rises at 6 dB/octave below 100 Hz, and constant output voltage above that.

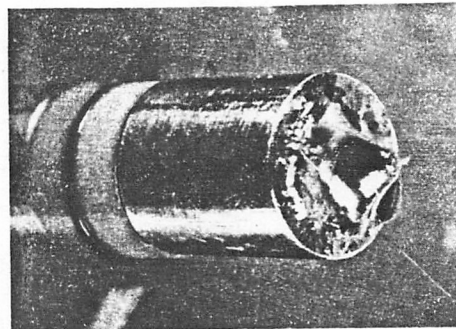

Sound Isolation

In the design of a transportable Reverberation Unit such as the EMT 240, the problems of mechanical and airborne sound isolation are of special significance. Such a unit will also be used in remote (O. B.) units in which considerable mechanical interference is to be expected. Entering or exiting such a van and opening and slamming the door during a recording produces considerable disturbances. In addition, such other interfering sound sources as the monitor speakers and the conversations of the engineers during the recording are also to be considered.

Airborne Sound Isolation

The requisite attenuation of airborne sounds is achieved through the use of a double shell construction. The picture shows the outer cover panel removed and the inner case in

the shape of a clam shell. This shell has an excellent and relatively constant sound isolation due to its stiffness (see curve 2 in the following figure). Above 1 kHz this isolation increases with frequency due to the mass of the system. Between these two frequency segments, however, there is a serious dip at 400 Hz caused by the resonance frequency of the clam shell.

The outer housing, a flat steel plate with a damping paste applied, which is screwed onto the housing practically air tight, produces additional attenuation as shown in curve 1. Both curves are additive and combine to give curve 3, which is the total sound isolation.

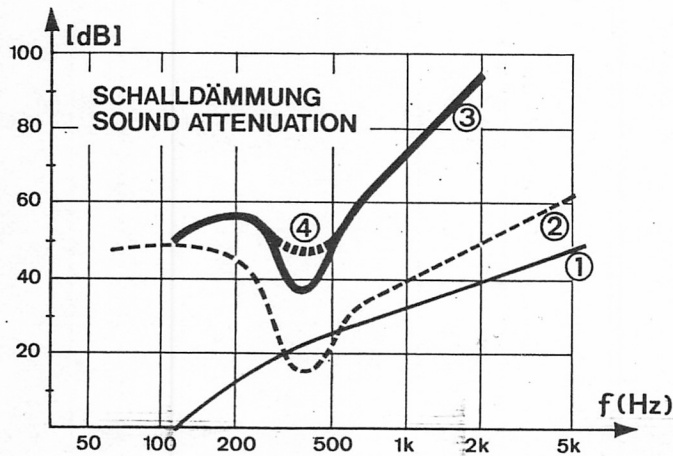

The sharp dip at 400 Hz is still visible even in curve 3. It is eliminated using a device consisting of a damped spring and mass, whose resonance is tuned to the dip frequency. This construction, produces the improved curve 4, and a sound isolation over the useful frequency range at times considerably above 50 dB. Together with the transducing properties of the foil this means that an external sound field of 74 dB SPL per third-octave produces interference which is still below the self-noise level.

Mechanical Sound Isolation

For mechanical noise interference, two different types of isolation measures must be considered.

- Low frequencies are reduced through suitable mass/spring systems
- high frequencies are transmitted as longitudinal waves through springs, which must be damped.

The low frequency isolation is accomplished in three stages. The first resonating system is

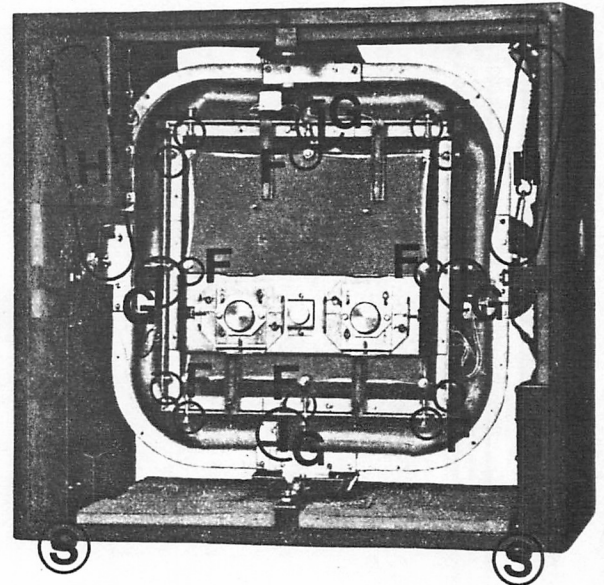

represented by the clam shell mass (including the mass of its contents) together with the long main springs (H). It is the intention to place the resonance of this first stage as low as possible. This was made possible by the large mass of the shell as well as a long, soft spring. The resonance of this first stage is approximately 2 Hz. In view of the fact that the use of long and soft springs creates a danger that the suspended mass may displace itself too far when its position is altered, additional stabilizing springs are used. This makes deviations from the normal set up position of the unit non-critical.

The second isolation stage is represented by the spring suspension (I) of the inner frame inside the shell. The resonance of this second isolation stage is considerably higher to prevent reinforcement of any interference at the resonance frequency of the first stage. The third isolation stage, finally, is represented by the spring suspension (F) of the gold foil itself. An additional fourth isolation stage (S) is created through use of shock mounts as feet for the entire unit. This makes it possible to utilize the complete mass of the unit for isolation.

All of the springs are heavily damped to avoid resonance peaks and to reduce longitudinal transmission of higher frequencies. At suitable spots such as the suspension of the tensioning frame, rubber bumper (G) are used for further attenuation of high frequency interference.

Setting the Unit up

The Reverb Foil may be set up practically anywhere, even in control rooms and remote or O.B. vans. The following points should be observed:

1. The SPL from monitor speakers measured directly at the unit case should not exceed 95 phon.
2. The unit may be tilted by as much as 10 degrees without problems. Should the EMT 240 be shipped or transported while at a slant, the position of the damping plate

may shift. That is why after every transport the reverberation time button (-) should be pushed for about 10 seconds.

3. Position the Unit in such a way as to allow it to move freely on its shock mounts. Any mechanical attachment of the unit during operation is to be avoided, since otherwise one of the isolation stages (see description on page 7) is bridged and isolation may be reduced.
4. Hard jabs or punches against the unit are to be avoided.

Electrical Connection

The pin connections of all input and output connectors are as follows:

- 1 = shield/screen
- 2 = Modulation (+)
- 3 = Modulation (-)

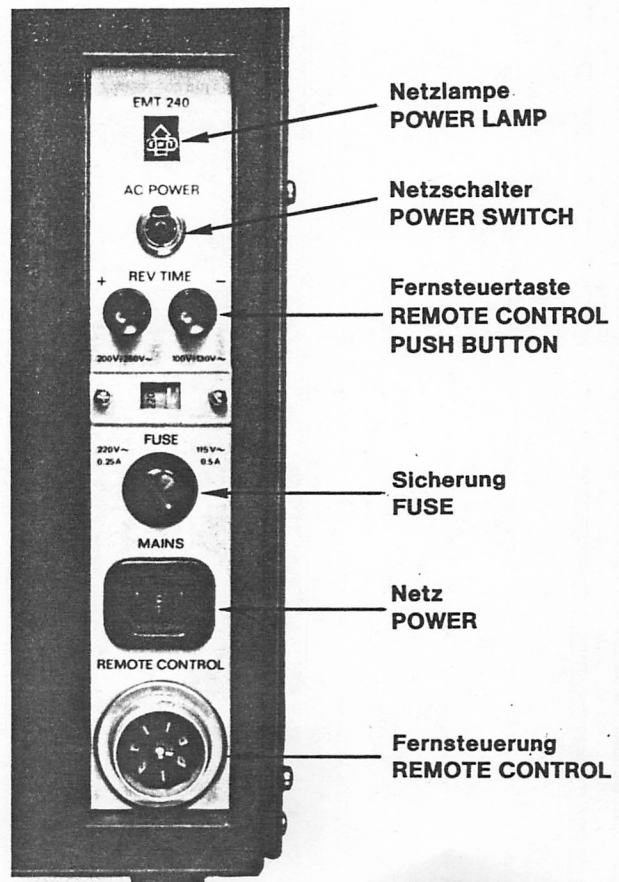
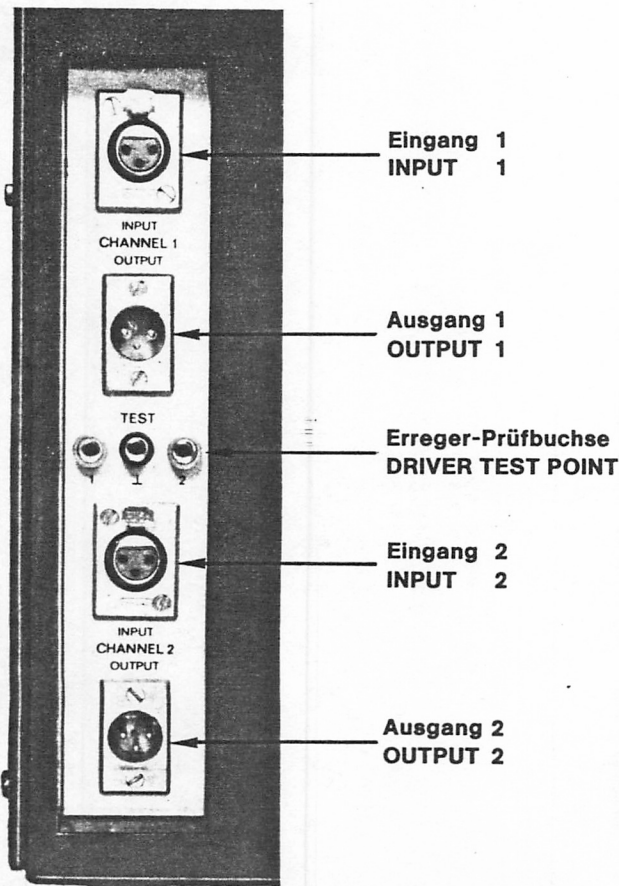

Remote control and Battery Operation

The remote control operating elements of the Reverb Foil EMT 240 are identical to those of the Reverberation Unit EMT 140 FB-TS. This conformance extends even to the use of the same 8-pin Tuchel connector. This makes it possible to use existing EMT 140 FB-TS remote controls as well as the installed wiring for the Reverb Foil EMT 240.

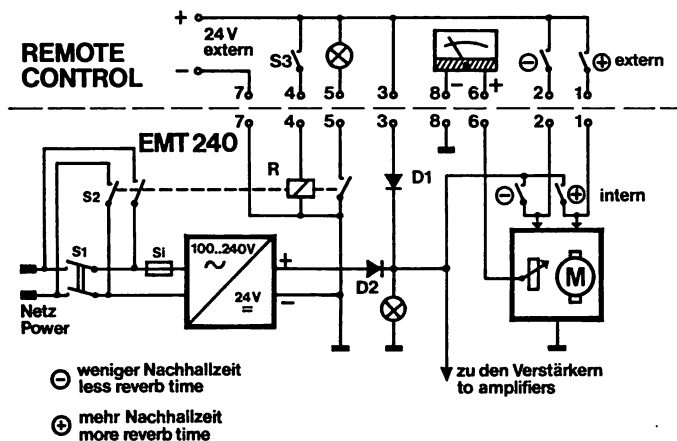

The Power supply in the picture at left can be switched to all of the world's power voltages. On the secondary side, approximately 25 VDC is produced, which serves both the remote control motor and the individual channel amplifiers.

This produces great flexibility of operation. The following connection variations are possible:

- Operating of the unit from AC mains, but the remote control from a 24 VDC central supply. This conforms to the operation of the EMT 140 FB-TS. This also permits the unit to be remotely switched on and off via relay R and switch S 2. Pin 3 of the connector is not used in this mode.
- Operating of the entire unit from a central 24 VDC supply or car battery. This mode also permits remote switch-on if point 4 of the remote control is connected to point 3 of the Reverberation Unit. Via diodes D 1 and D 2 the Reverb Foil EMT 240 may be

simultaneously operated from a 24VDC central supply and AC mains. Normally, the slightly higher DC voltage from the AC supply blocks the battery supply and therefore saves the batteries. In case of AC power failure, the batteries take over at once automatically providing fail safe operation.

- When no external 24 VDC supply is available, remote control is still possible from the unit's internal AC power supply. Diode D 1 must be shorted in this case (see figure on page 15). Remote controlled turn-on of the unit is not possible in this case.

According to the adjacent schematic, the remote control connector pins have the following connections:

- 1 = Reverberation time button (+)
- 2 = Reverberation time button (-)
- 3 = +24 VDC
- 4 = Remote turn-on
- 5 = Tally lamp
- 6 = Time meter (+)
- 7 = -24 VDC
- 8 = Time meter(-)

The movement of the damping plate is produced by a linear motor, operated by the two push buttons on the left side of the schematic. No damage results from the operation of either or both buttons simultaneously on the unit itself or on the remote control. The damping plate moves as long as the button is depressed. By observing the reverberation time meter, it can be determined when the desired reverberation time has been reached and the button released.

CAUTION: to prevent mechanical shock when the linear motor starts, its control current is raised slowly via an RC network. After a button is pushed, therefore, a short time will elapse before a change in reverberation time is noted on the meter.

The combination of several remote controls is shown in the next schematic.

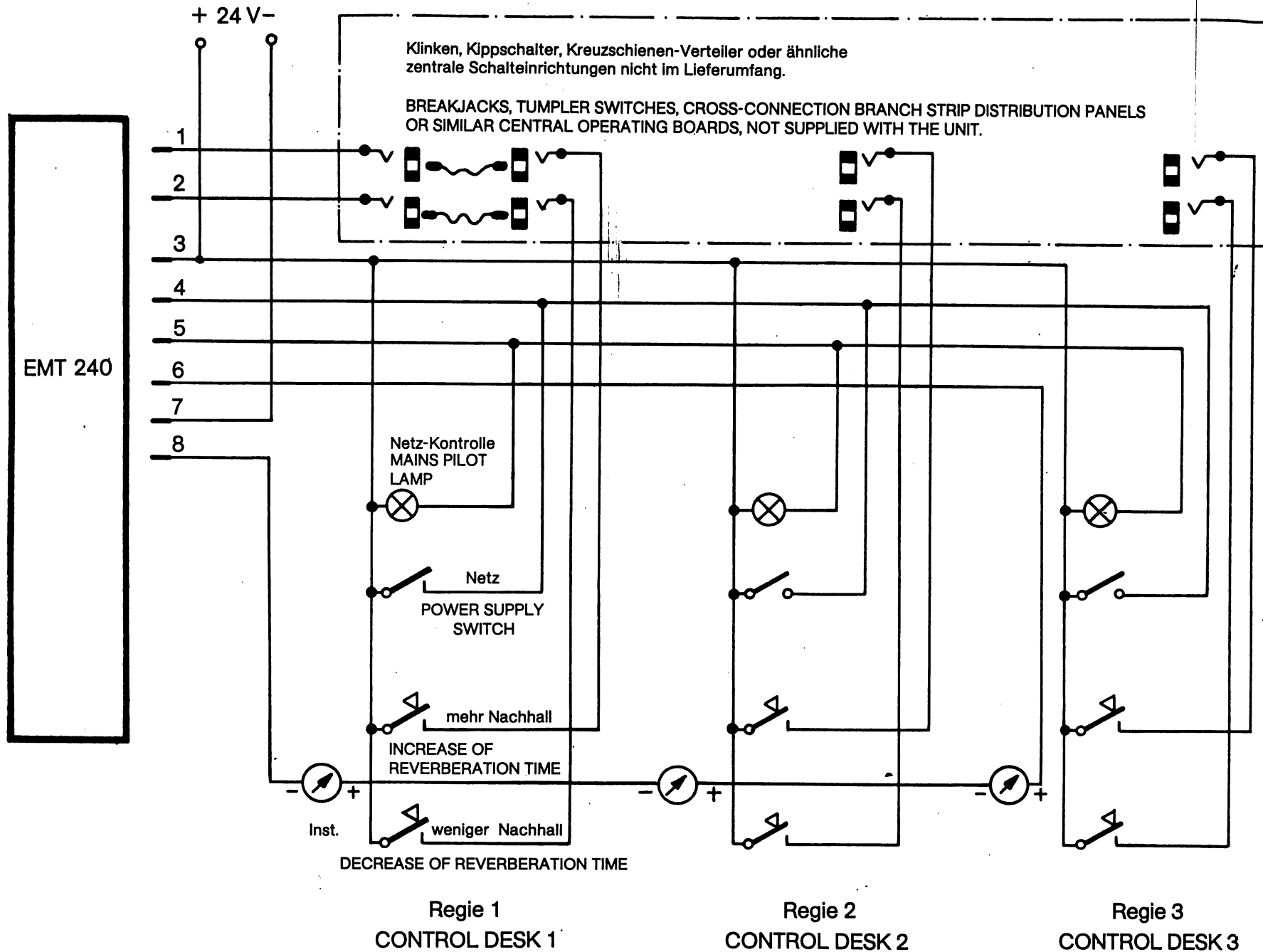

Schaltung mehrerer Regie-Bedienungsteile
 Circuit diagram for multiple control desk arrangements **EMT 240**



RE: EMT 240

Alignment hints for units beginning with serial No. 195
(with Amplifier EMT 262 beginning with serial No. 23337).

Beginning with the above named serial numbers, the drive amplifiers have been coupled via pin 5 of the amplifier connector.

The heretofore published level indications are still valid, but for calibration or operation with one amplifier inserted.

There are three alignment possibilities:

Input: 0 dB_{abs}, f = 1 kHz (third octave white noise)
and T = 2 sec, produces at the Output:

	<u>Test Jack</u>	<u>Audio Output</u>
I. 1 amplifier plugged into unit	-10 dB	0 dB
II. 2 amplifiers plugged into unit, feed to only one input	-16 dB	-3 dB
III. 2 amplifiers plugged into unit, both inputs fed from same source	-10 dB	+3 dB

Note: Measure the level at the test jack using high impedance millivolt meter, $R_I \cong 100 \text{ k}\Omega$.

Drive Amplifier:

For a 0 dB nominal line level, the level control R 1 (in the amplifier, accessible at the front panel) is to be adjusted so that a level of -13 dB is obtained at test point (C).

The R 123 potentiometer sets the limiter threshold. After nominal alignment: input = output = 0 dB, application of a +8 dB signal to the input should result in 0.5 dB limiting at the output.

The R 140 potentiometer determines the total amplification as a function of the transducer sensitivity.

The potentiometer R 1 (in the reverb unit, 22 k Ω at the drive transformer) is to be adjusted to yield a level of -10 dB at the test jack.

Pick-up Amplifier:

The R 2 control (accessible at the front panel) determines the pick-up amplification. For nominal amplification of approx. 21 dB, the weighted noise level at the output should be $-54 \text{ dB}^{\text{peak}}$ equivalent to an unweighted noise of approx. $-62 \text{ dB}^{\text{rms}}$.

Note: The front panel accessible gain controls are set to the following scale marks for the standard factory alignment:
input : 5 - 7
output: approx. 7

Alignment and Calibration

IMPORTANT! A reverberation time of 2 seconds is to be set for all measurements!

applicable from serial no. 139 on

The level alignment of the Reverb Foil EMT 240 may be undertaken in various ways, all of which produce the same result.

1. Alignment according to the "Braunbuch" specifications 054 or V 54, only applicable to studio systems set up according to "IRT BRAUNBUCH" specifications:
 - 1.1. Feed a test signal of 1 kHz at 0 dB_{abs} from a low impedance source oscillator ($R_i \leq 50$ ohm) to the input.
 - 1.2. Measure at the test jack using a high impedance volt meter or multi-meter ($R_i \geq 10$ kohm/volt); set INPUT potentiometer to produce reading of 0.245 V (≈ -10 dB_{abs})
 - 1.3. Replace the test signal with a 1 kHz third-octave white noise signal (e.g. part 1 of the Reverberation test tape) at a level of 0 dB. Adjust OUTPUT potentiometer so that 0 dB level is measured at the output of the unit.

Since the measuring instrument used influences the reading of white noise level, it is recommended that the same meter be used both for measuring input and output levels.

2. Alignment for studio systems using peak level indicators and any peak alignment levels:
 - 2.1. Feed a test signal of 2 kHz at standard line level (e.g. +6 dB) from a low impedance source oscillator ($R_i \leq 50$ ohm) to the input.
 - 2.2. Measure at the test jack using a volt-meter, peak level indicator or high impedance multi meter ($R_i \geq 10$ kohm/volt); set the INPUT potentiometer to produce a reading of 0.49 V (≈ -4 dB_{abs}).
 - 2.3. Replace the test signal with a 1 kHz third - octave white noise signal (e.g. part 1 of the reverberation test tape) at standard line level (measured using studio peak indicator). Adjust OUTPUT potentiometer so that standard line level also appears on the peak indicator at the output of the unit.

3. Alignment using vu meter:

- 3.1. Feed a test signal of 1 kHz at standard line level (e.g. +4, +6, or +8 dB) reading ZERO on your standard vu meter with proper vu range pad, to the unit's input.
- 3.2. Measure at the test jack using a high impedance volt meter or multi-meter ($R_i \geq 10$ kohm/volt); set the INPUT potentiometer to produce a reading of 0.245 V (≈ -10 dB_{abs}).
- 3.3. Replace the test signal with a 1 kHz third-octave white noise signal (e.g. part 1 of reverberation test tape) or program material at standard line level measured using your standard vu meter) and adjust OUTPUT potentiometer so that identical levels appear both at the input and output of each channel.

To check the transmission characteristics and to facilitate alignment of the Reverb Foil EMT 240 we can supply a test tape (tape speed 15 ips (38.1 cm/s) equalization IEC/CCIR) which obviates the use of white noise generator and third-octave filter. This test tape has the following program:

1. Level alignment part

Announcement;
Third-octave band white noise; mid frequency 1 kHz; peak recording level; duration approximately 2 min.
Yellow leader

2. Frequency response part

Announcement;
Third-octave band white noise. 27 mid frequencies from 40 Hz - 12.5 kHz each with announcement; (duration each band 20 s)
14 dB under peak recording level.

Alignment using sine wave signal is not possible since the reverb foil – as with every echo chamber – produces a multitude of closely spaced self-resonances and therefore would yield a highly frequency dependent output level.

The frequency response is also best determined using third-octave white noise, but otherwise measured as usual: The output level as a function of frequency is measured with a constant level (-14 dB) at the reverberation unit input. The response should lie within the tolerance (low frequency cut-off filter in 0 dB position).

In general it can be stated that minor deviations from the tolerances are not acoustically noticeable.

A level recorder permits this measurement to be made using a sweep signal. The time constant of the recorder must be large enough so that the level variations for small shifts in frequency are integrated. Further information regarding sweep frequency measurements may be found in the instructions for such equipment. The drive section of the Amplifier EMT 262 may have its low frequencies attenuated with three different time constants. The switch on the front panel of the amplifier is to be operated with a screw driver. The positions "0 dB" to "-24 dB" are shown in the response graph. Purpose of the low frequency cut-off: In a room the low frequency reverberation components always have a longer reverberation time than the high. Often it is desirable, from a production stand point, to reduce the low frequencies in the spectrum with respect to the high frequencies. In an echo chamber this requires structural changes, such as low frequency absorbers. In the EMT Reverberation Foil, the same effect is achieved with a multi-step, low frequency cut-off filter.

Amplifier

The Reverb Foil EMT 240 contains two identical drive/pick-up amplifiers EMT 262 as well as two drivers and two pick-ups.

This permits either:

use of traditional reverberation feed methods in which the two stereo channels are combined in the console into a mono (M) signal which is fed to the Reverb Foil EMT 240. In this case one of the two inputs stays unused.

or:

each stereo channel may be fed individually to the Reverb Foil EMT 240. In this case the difference signal (S) is not suppressed and musical information contained in the S channel is reverberated.

The amplifier EMT 262 has the following external adjustment controls:

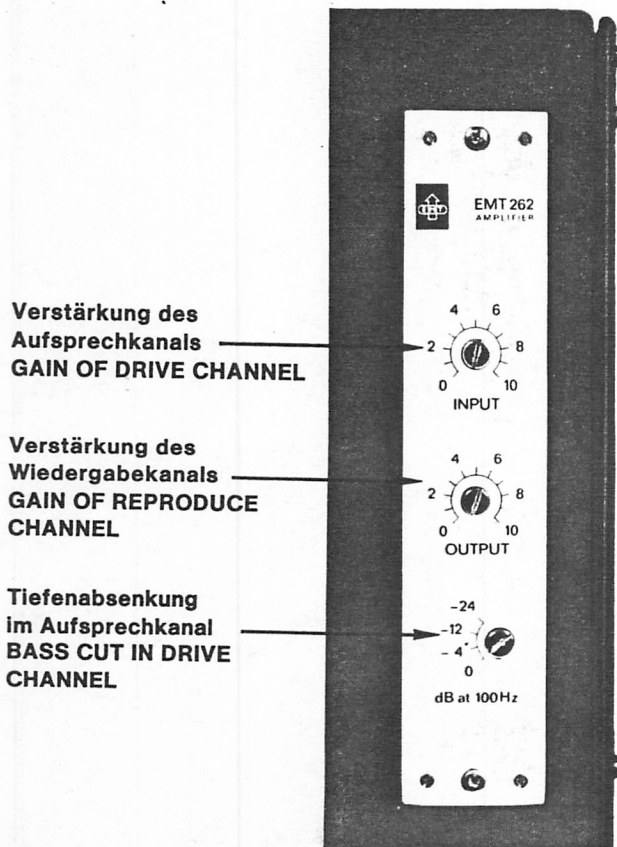

Drive limiter

To prevent overload of the foil, the drive section of the amplifier contains a limiter whose threshold is about 2 dB above the aligned level. The static curve of this limiter is shown in the next diagram.

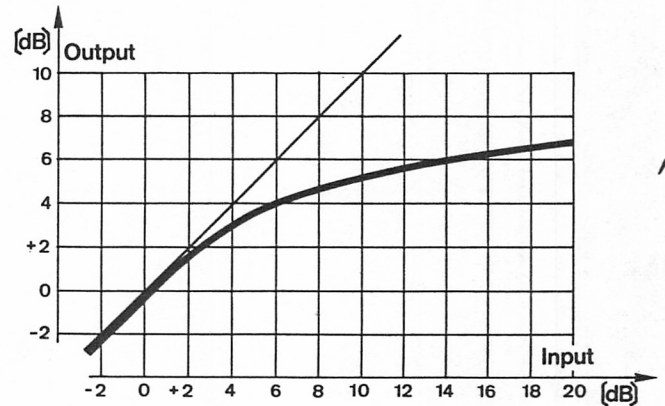

Reproduce expander

The pick-up section of the amplifier EMT 262 contains an expander with a special curve as shown in the following diagram. This serves not only to improve the insensitivity of the unit to its own and outside noise interference, but also shortens the reverberation time by about 10%. As is evident from the curve, the expander has a very small ratio of about 1.1 and is linear over a 60 dB range. The reverberation decay therefore shows no bending of the reverberation curve.

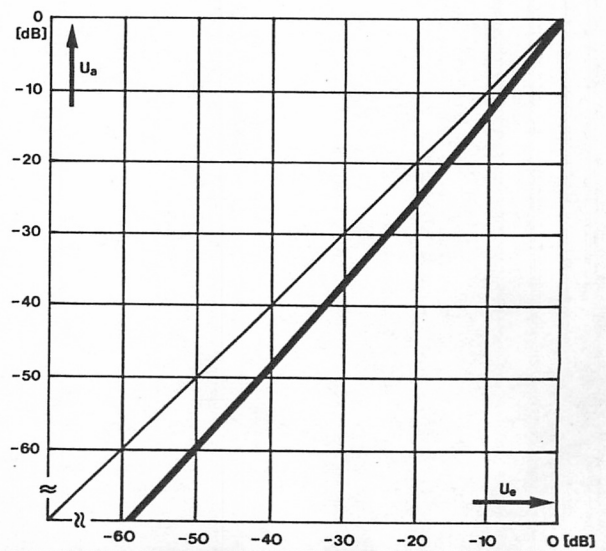

Adjustments

Connection of Chassis power supply voltage protective AC ground external 0-volt.

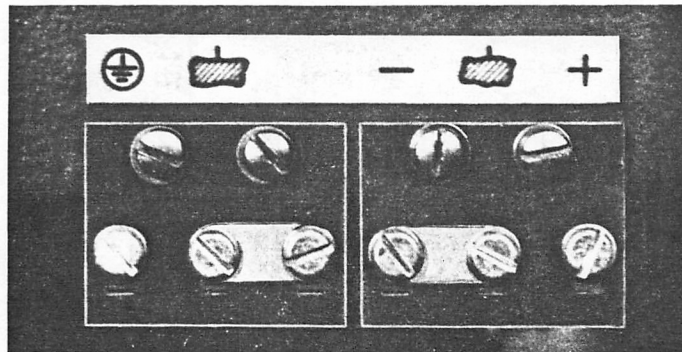

Chassis protective AC ground: Connected when strap is on left hand side.

The unit comes delivered with the chassis protective AC ground connected.

Chassis power supply voltage: The strap in the left position connects -24 V with chassis, in the right position +24 V with chassis.

One of the two potentials must always be connected to chassis!

The unit comes delivered with the connection -24 V and chassis.

Chassis external 0-volt: under "external 0-volt" one means the potential of the connected cable shields of the input and output cables (pin 1 on the Switchcraft or Cannon connector). They can be connected to chassis by means of a strap on the amplifier mating rack connector. The unit is delivered with this strap connected on each channel.

A change in the wiring as delivered from the factor is only then necessary if hum results on installation. When operating the unit in a van from 24 VDC, that side of the supply must be grounded to the chassis which is also grounded in the van, otherwise a short circuit may result from screws on the unit's case touching metal parts of the vehicle.

AC power voltage change

To change to a different AC power voltage simply slide the switch on the AC connection panel to the proper voltage.

Operation with internal power and Remote Control

To bridge diode D 1, remove the cover of the power supply, desolder the wire from terminal 10 and connect to terminal 9. The location of the connections may be found on the wiring layout drawing.

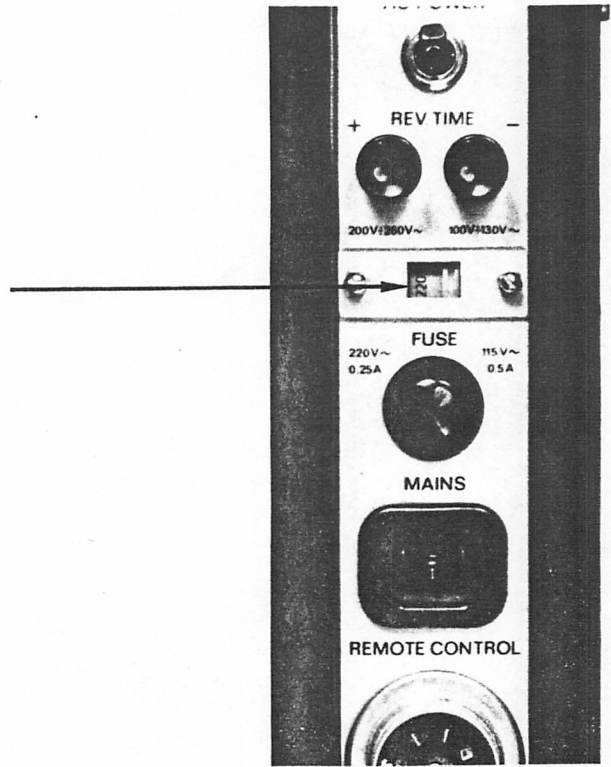

Position of adjustment points

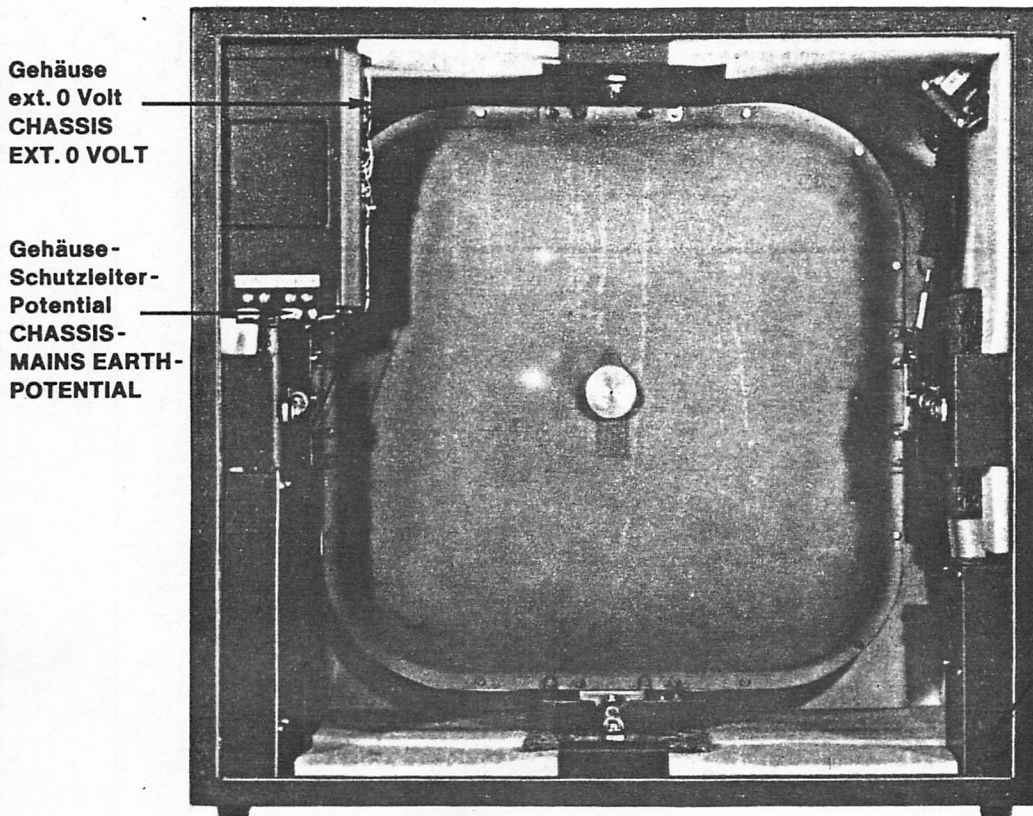

*D202 1U
REVERB FOL EMT 240
SCHEMATIC

D 1*
(Betrieb mit eigener Versorgung und Fernsteuerung)
(POWERING THE REMOTE CONTROL FROM THE INTERNAL POWER SUPPLY)

Technical Data

Reverberation time referred to 500 Hz	0,7 ... 5 s
Noise level at $T_r = 2$ s	
Unweighted Signal-to-Noise ratio, rms	$\cong 65$ dB
Weighted Signal-to-Noise ratio, peak	$\cong 60$ dB
Minimum input signal for full drive	
Peak measured	0.775 V rms (0 dB)
vu measured	approx. 0.4 V rms (- 5 dB)
Input impedance	$\cong 5$ k Ω , balanced and floating
Maximum output level at 1 kHz and $T_r = 2$ s	+ 21 dBm for 1% THD
Usual reverberation return level	- 6 ... - 10 dB, relative to direct channel
Output source impedance	$\cong 40$ Ω , balanced and floating
Minimum load resistance	200 Ω
Remote control	Silicone damped linear motor with control electronics and position indicator.
Control voltage requirement	24 VDC / 0.25 A
Power requirement	
a) AC supply	switchable 200 ... 250 V or 100 ... 130 V, 50/60 Hz
b) DC supply	24 VDC / 0.8 A
Weight	67 kg (148 lbs.)
Dimensions	640 x 300 x 625 mm (25½" x 12" x 25") (w x d x h)

Subject to change.

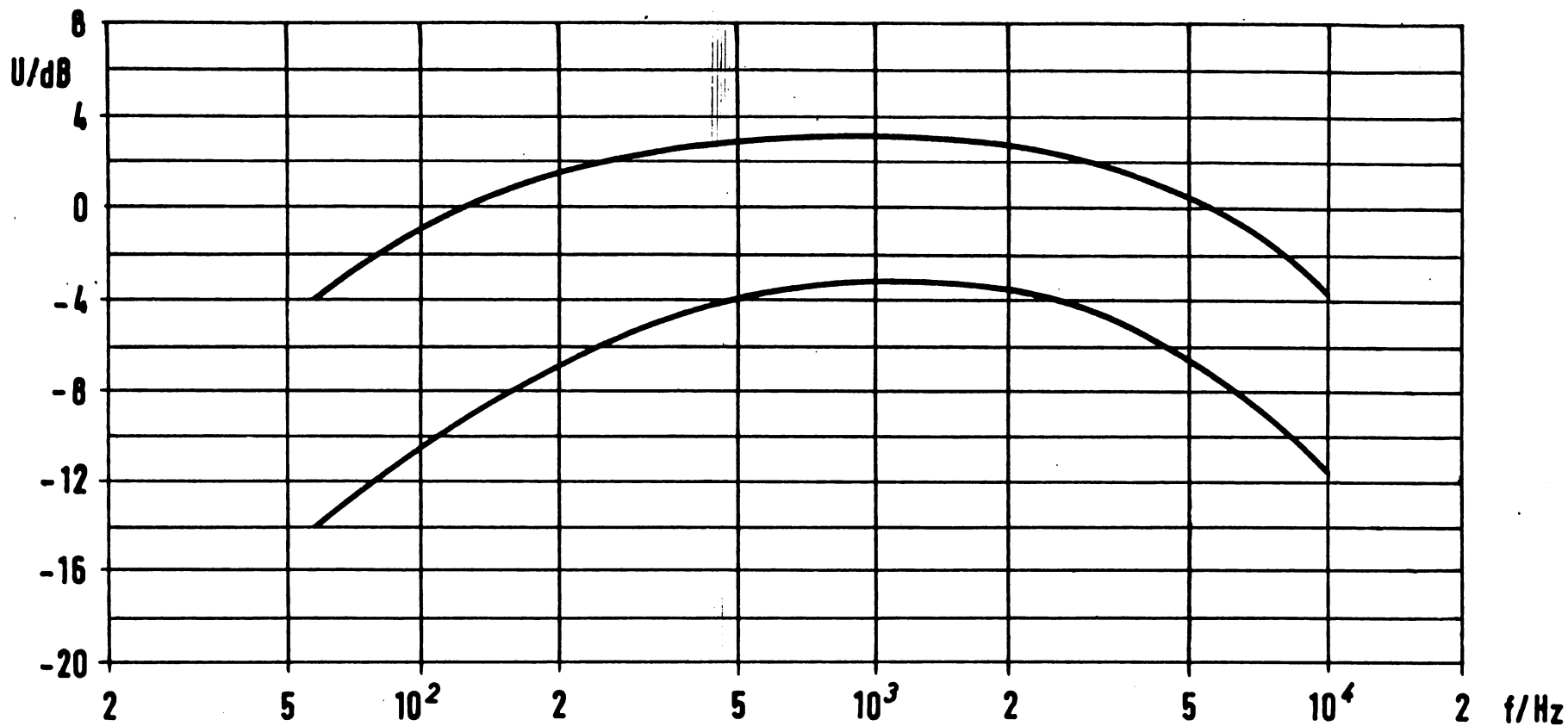

Toleranzbereich des Frequenzganges der gesamten Nachhallrichtung $U_A = f(f)$ bei $U_E = \text{const.}$, $T = 2\text{s}$
 Tolerance range of frequency response (total) for reverberation unit $U_{\text{output}} = f(f)$ at $U_{\text{input}} = \text{const.}$, $T = 2\text{s}$

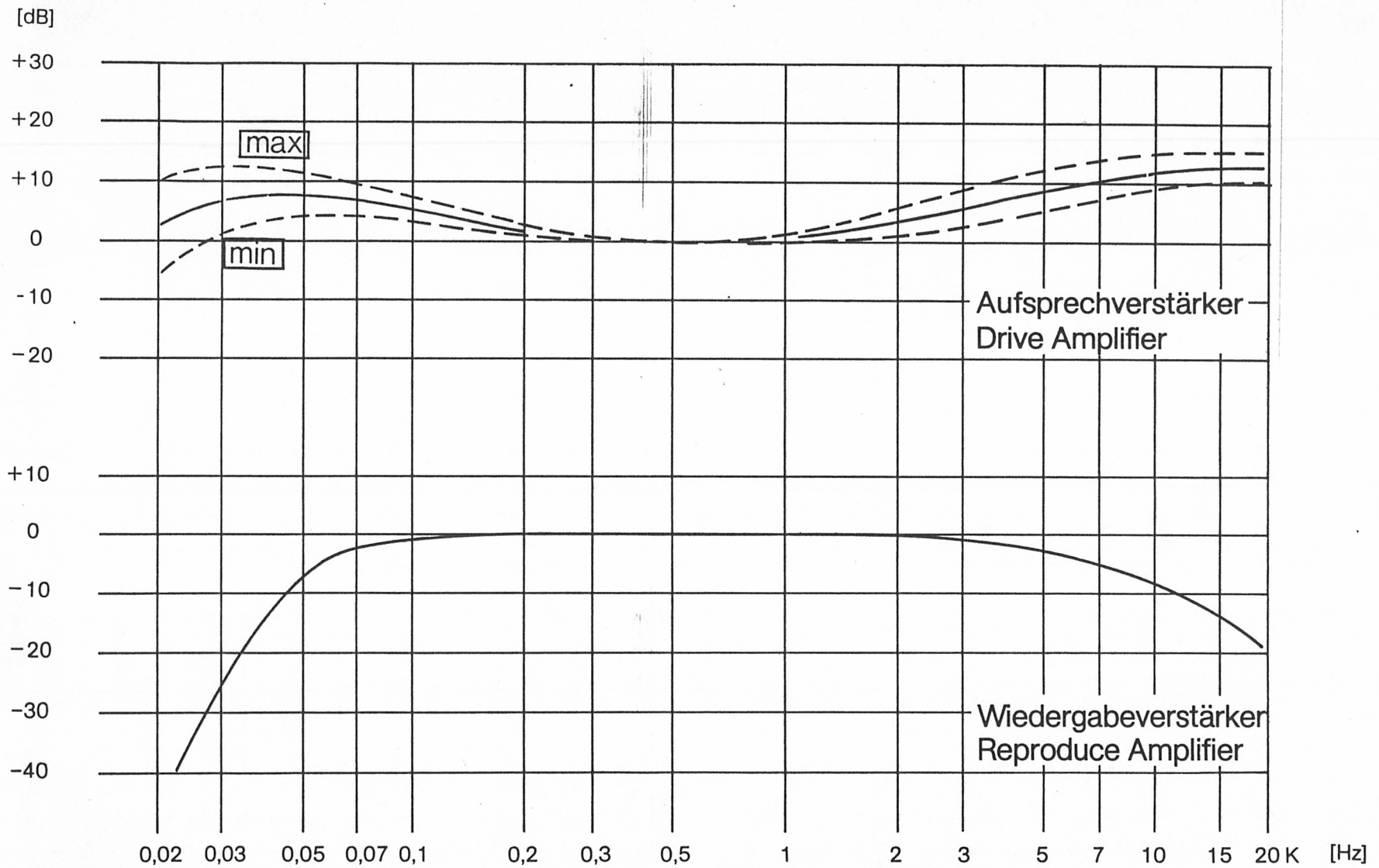

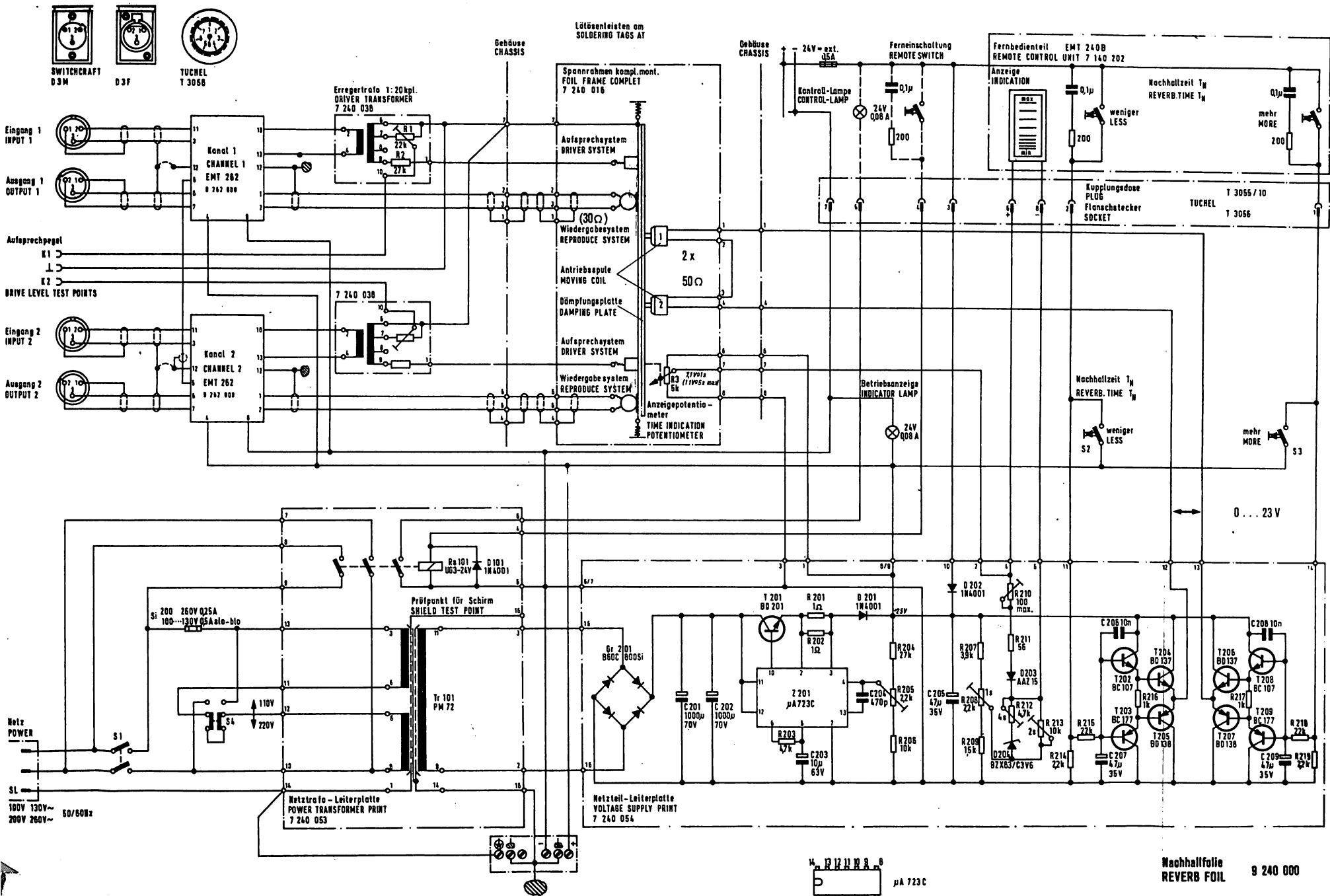

Nachhallfolie
REVERB FOIL 9 240 000

Schaltbild Nachhallfolie
Circuit diagram Reverb Foil **EMT 240**

Technische Änderungen vorbehalten!
SPECIFICATION CHANGE RESERVED
Beginn ab Geräte-Nr. 0195
BEGINNING WITH SERIAL NO. 0195

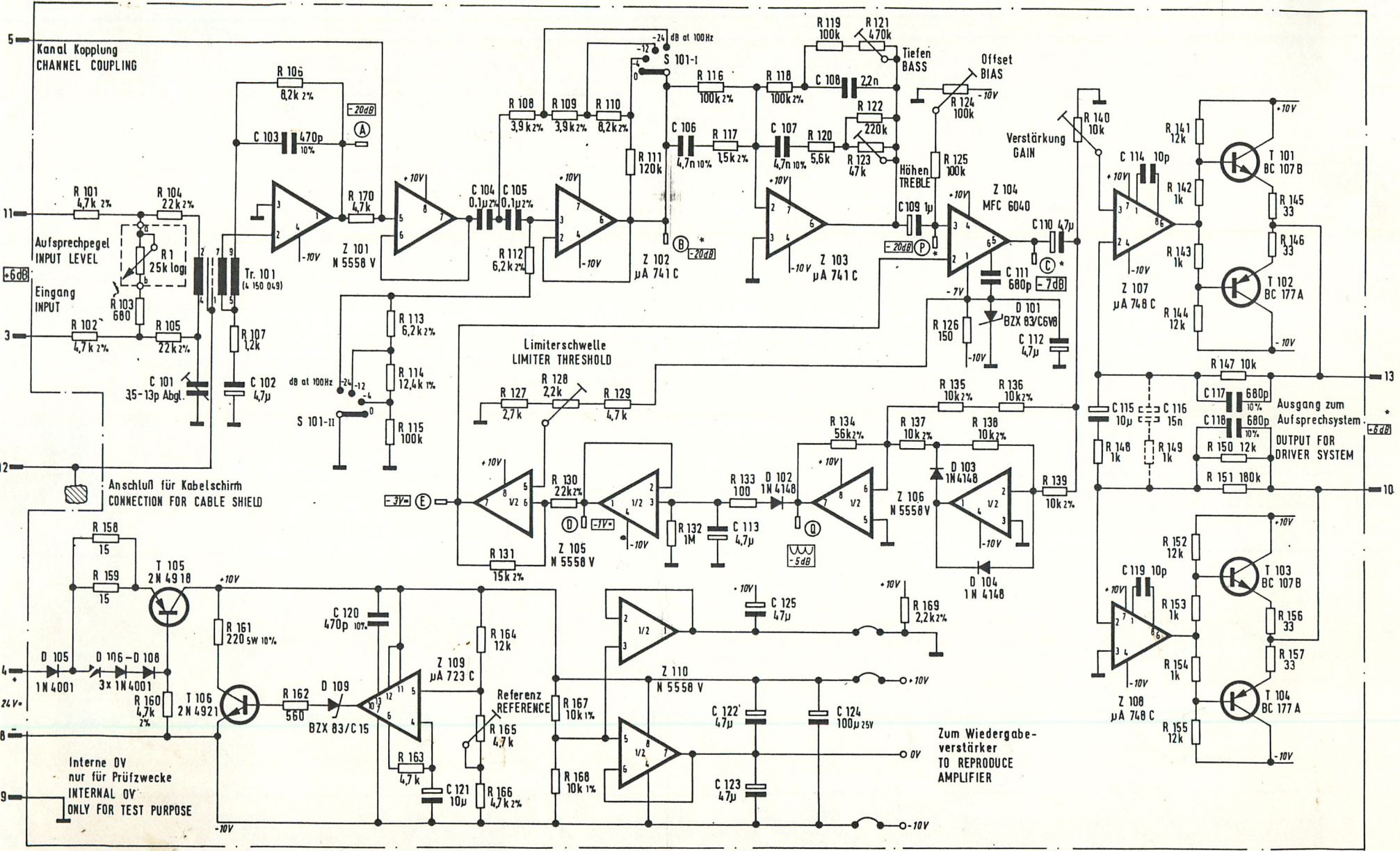

*Die Testpegel beziehen sich auf die Messung ohne Kanal-Kopplung (nur 1 Verstärker im Gerät EMT 240); mit der Kopplung und nur einem modulierten Verstärker sind die Pegel um 6 dB kleiner.

Technische Änderungen vorbehalten! SPECIFICATION CHANGE RESERVED
 Gültig ab Serien-Nr. 23 337 BEGINNING WITH SERIAL NO. 23 337
 Aufsprechverstärker 7 262 003 DRIVE AMPLIFIER

Schaltbild Aufsprechverstärker EMT 262
 Circuit diagram Drive Amplifier

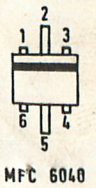

MFC 6040

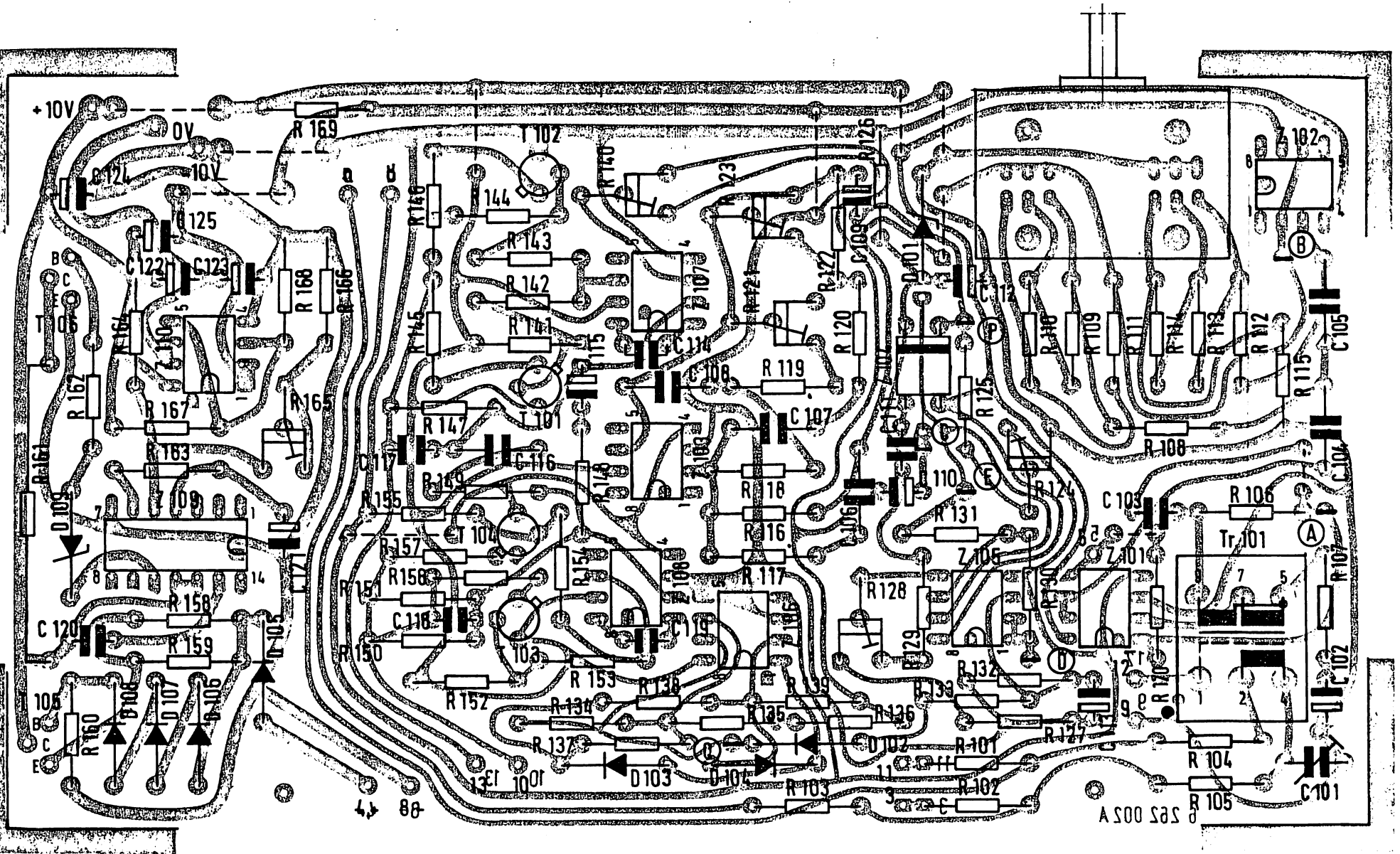

Sicht auf Bauelemente-Seite
View of component side

Printplatte Aufspeechverstärker
Print board Drive Amplifier

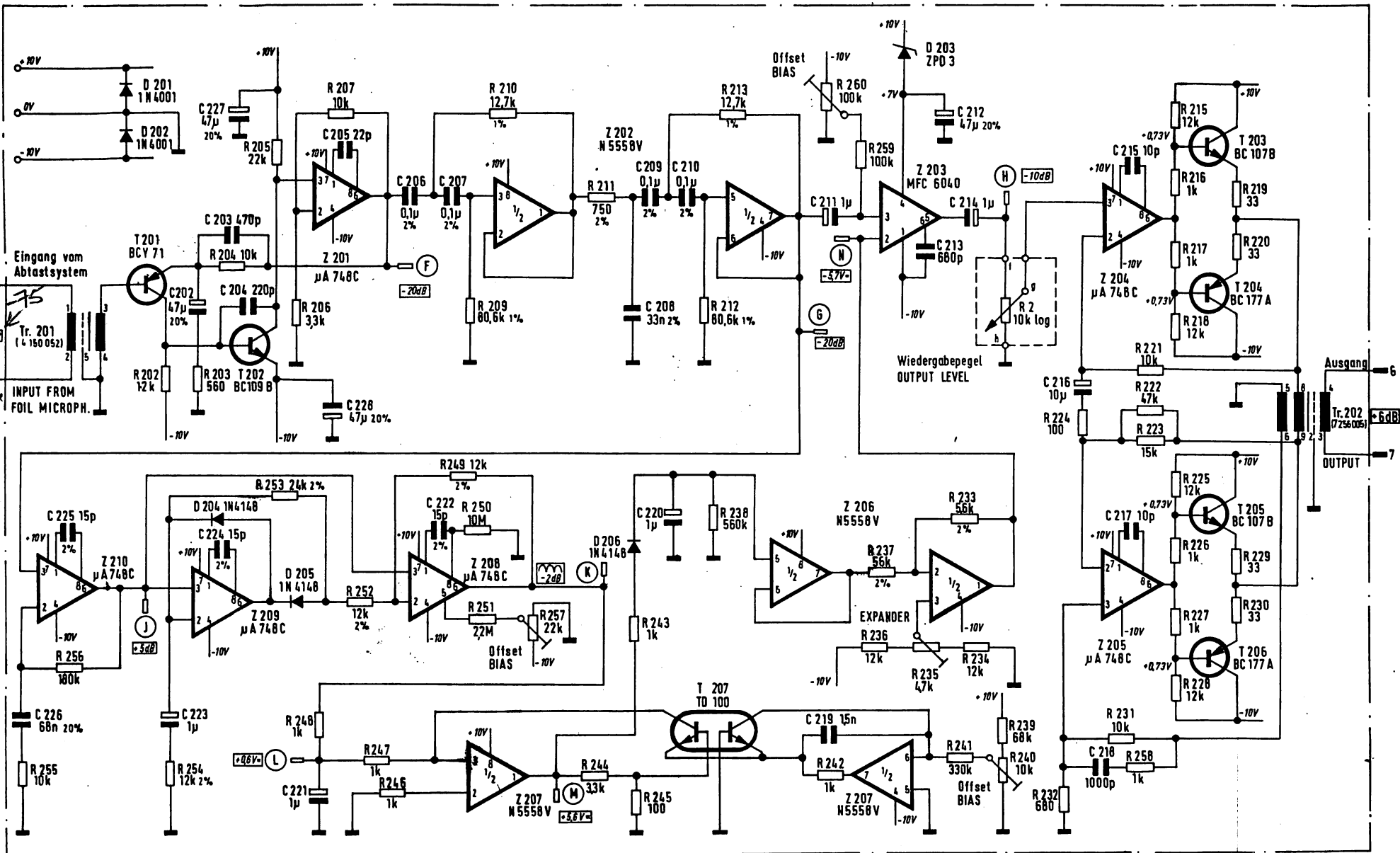

A-N Meßpunkte / TEST POINTS
 -p Verbindungsleitungen / INTERCONNECTIONS
 -1V = Test Gleichspannung gegen 0 Volt intern
 QC-TEST VOLTAGE AGAINST INTERNAL 0 VOLT

-10 dB Testpegel, Gleich- oder Wechselspannung unter Testbedingung, Testsignal 1 kHz
TEST LEVEL, DC OR AC UNDER TEST CONDITIONS, TEST SIGNAL 1 kHz
 Eingang +8 dB Aufsprechpegel +10 dB
INPUT DRIVE LEVEL
 Wiedergabepegel -81 dB Ausgang +3 dB
REPRODUCE LEVEL OUTPUT

Technische Änderungen vorbehalten!
SPECIFICATION CHANGER RESERVED
 Gültig ab Serien-Nr. 23 337.
BEGINNING WITH SERIAL NO. 23 337

Schaltbild Wiedergabeverstärker
Circuit diagram Reproduce Amplifier
 Wiedergabeverstärker
REPRODUCE AMPLIFIER 7 282 005

EMT 262

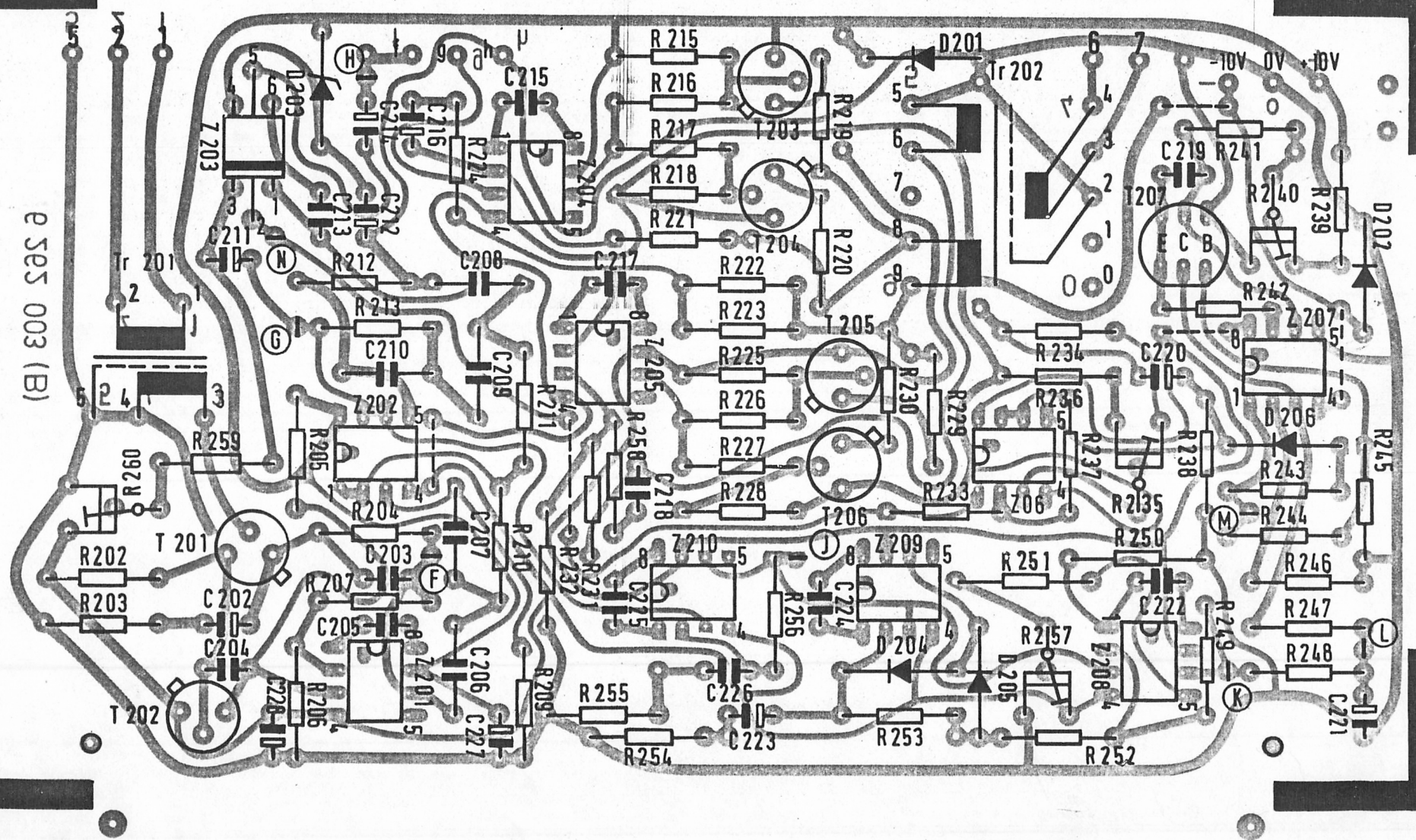

Sicht auf Bauelemente-Seite
View of component side

Printplatte Wiedergabeverstärker
Print board Reproduce Amplifier **EMT 262**

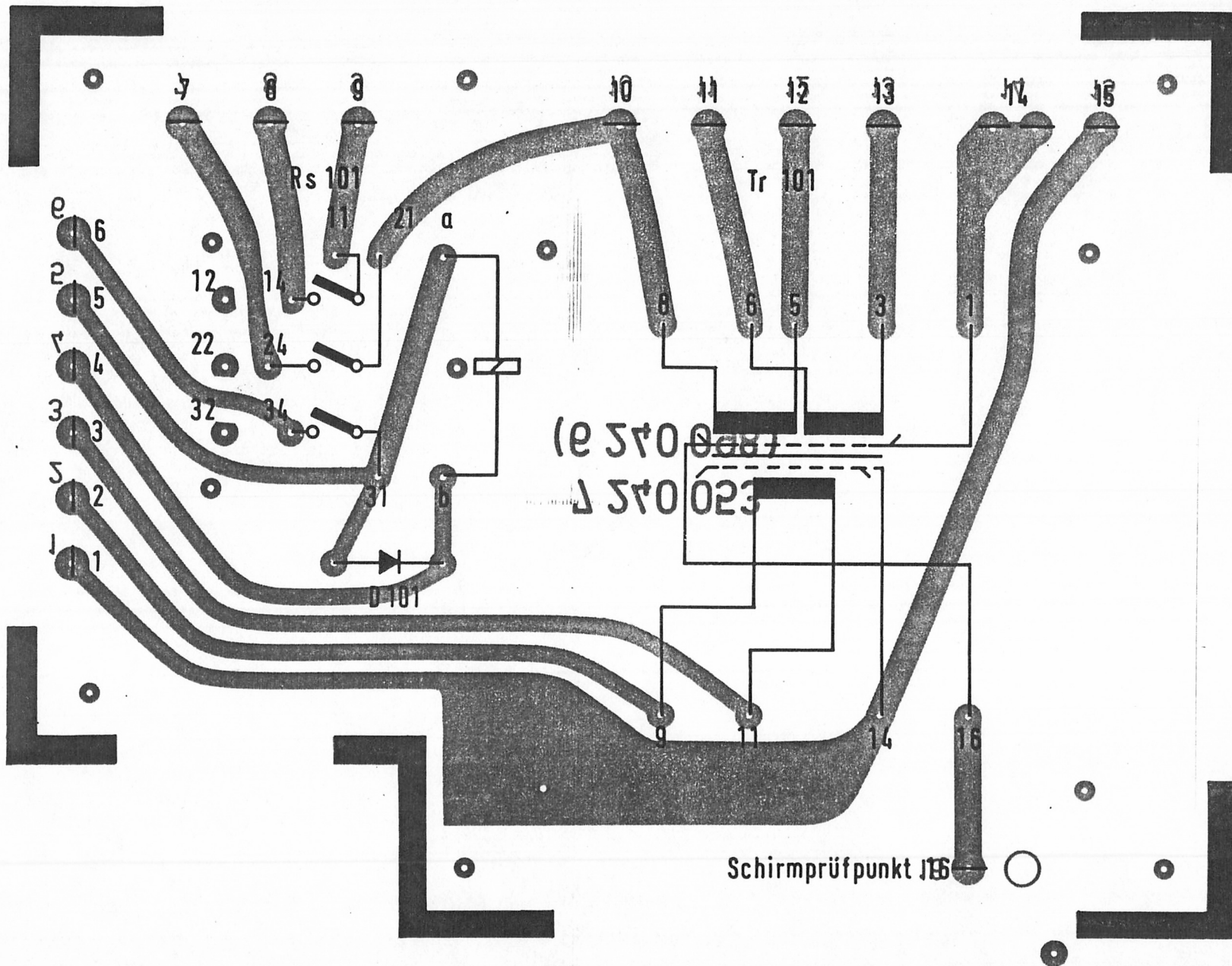

Sicht auf Bauelemente-Seite
View of component side

Printplatte Netztrafo
Print board Power transformer **EMT 240**

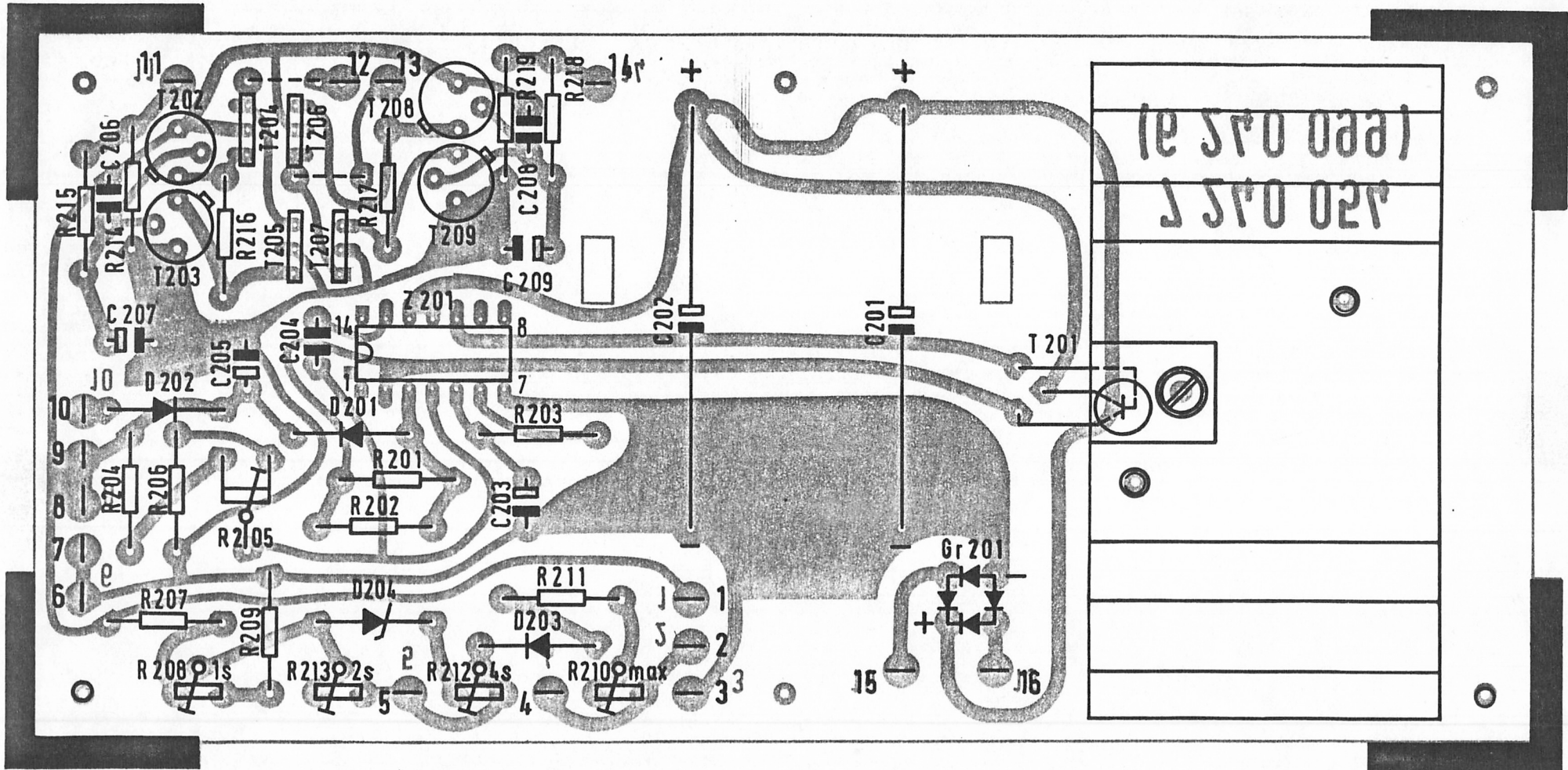

Sicht auf Bauelemente-Seite
View of component side