

FIG. 1 is a perspective view taken from above and at one front corner of the audio control panel.

FIG. 2 is a front elevation view;

FIG. 3 is a rear elevation view.

FIG. 4 is a top plan view thereof.

FIG. 5 is a bottom plan view.

FIG. 6 is an end elevation view, the opposite end being a mirror image thereof.

Fig. 1

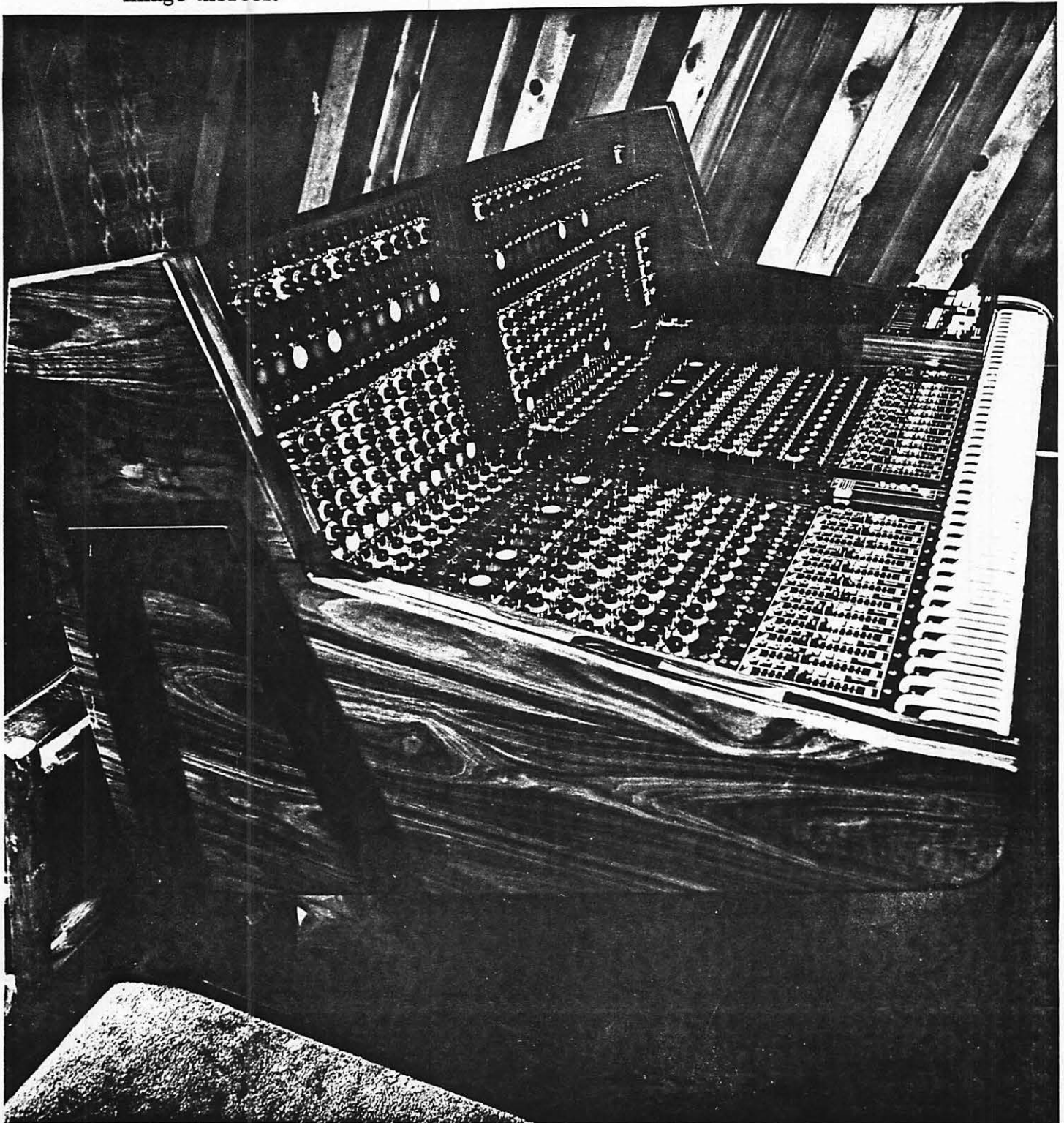

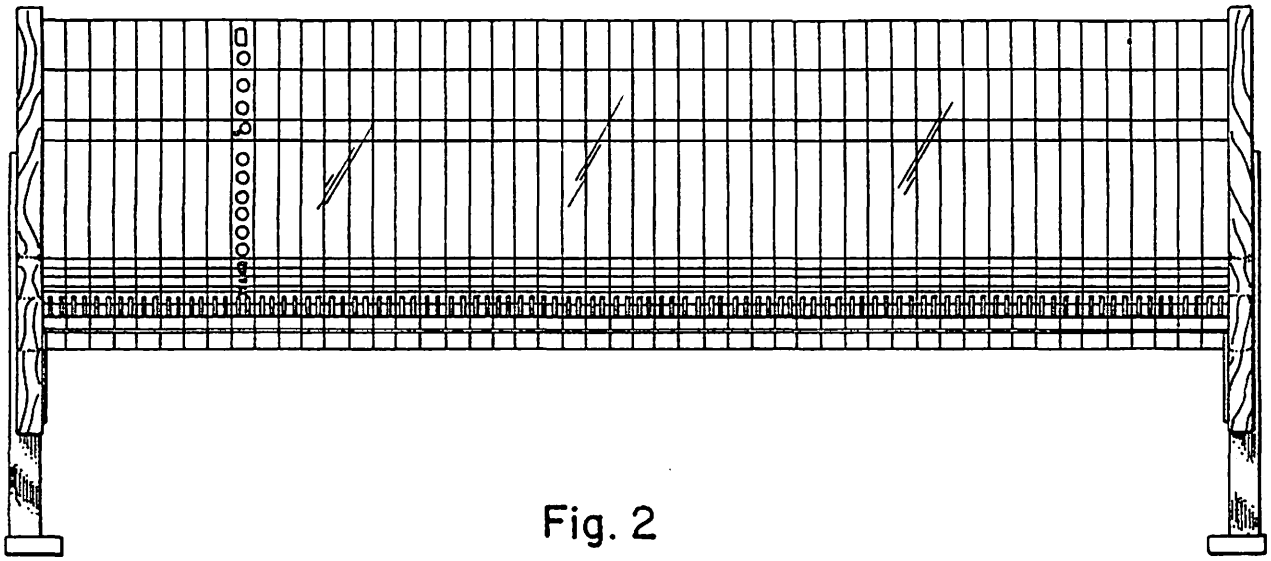

Fig. 2

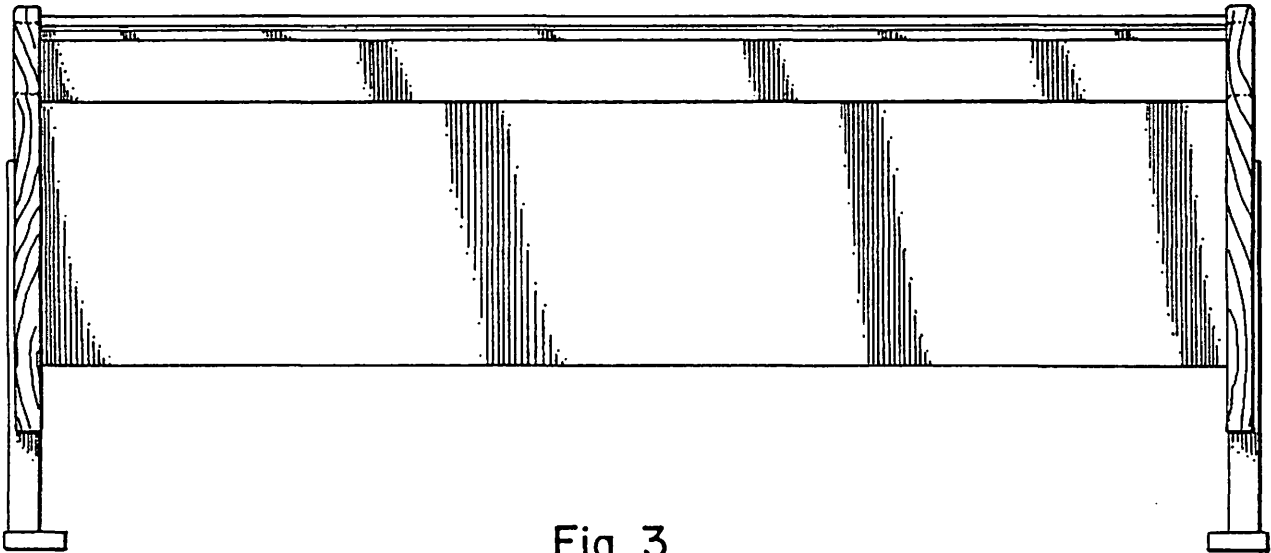

Fig. 3

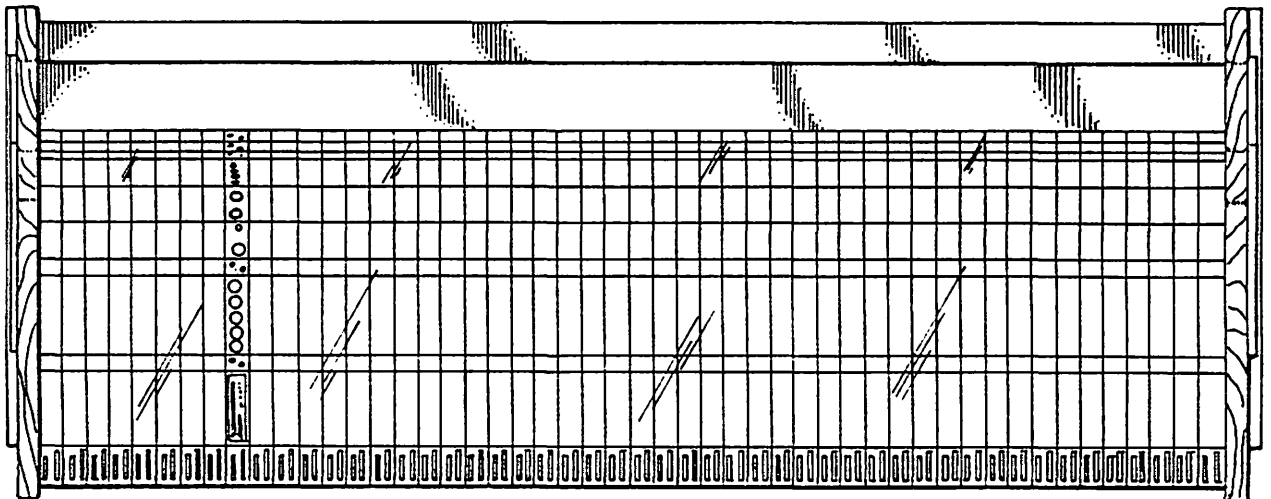

Fig. 4

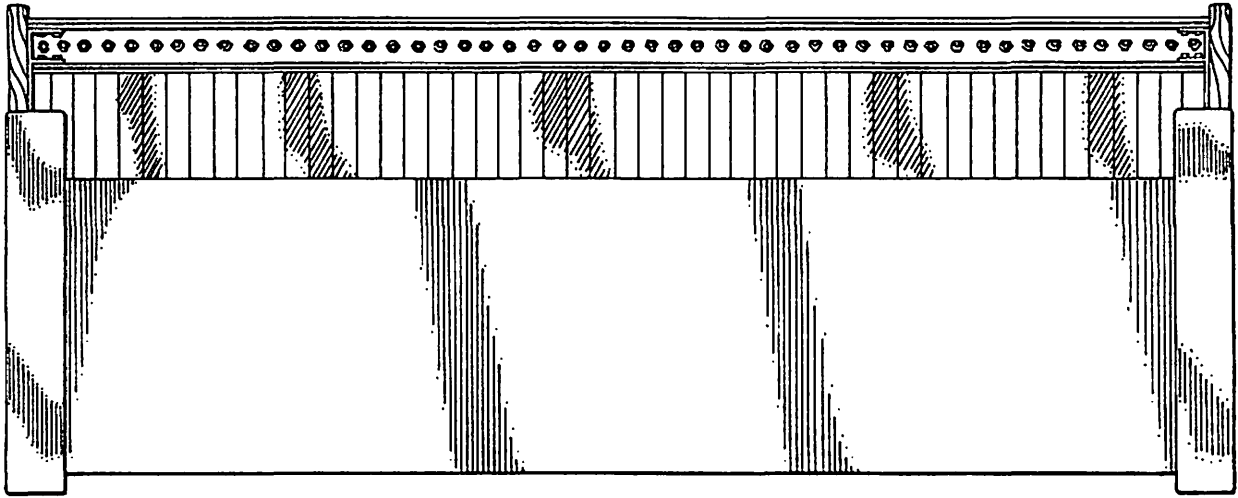

Fig. 5

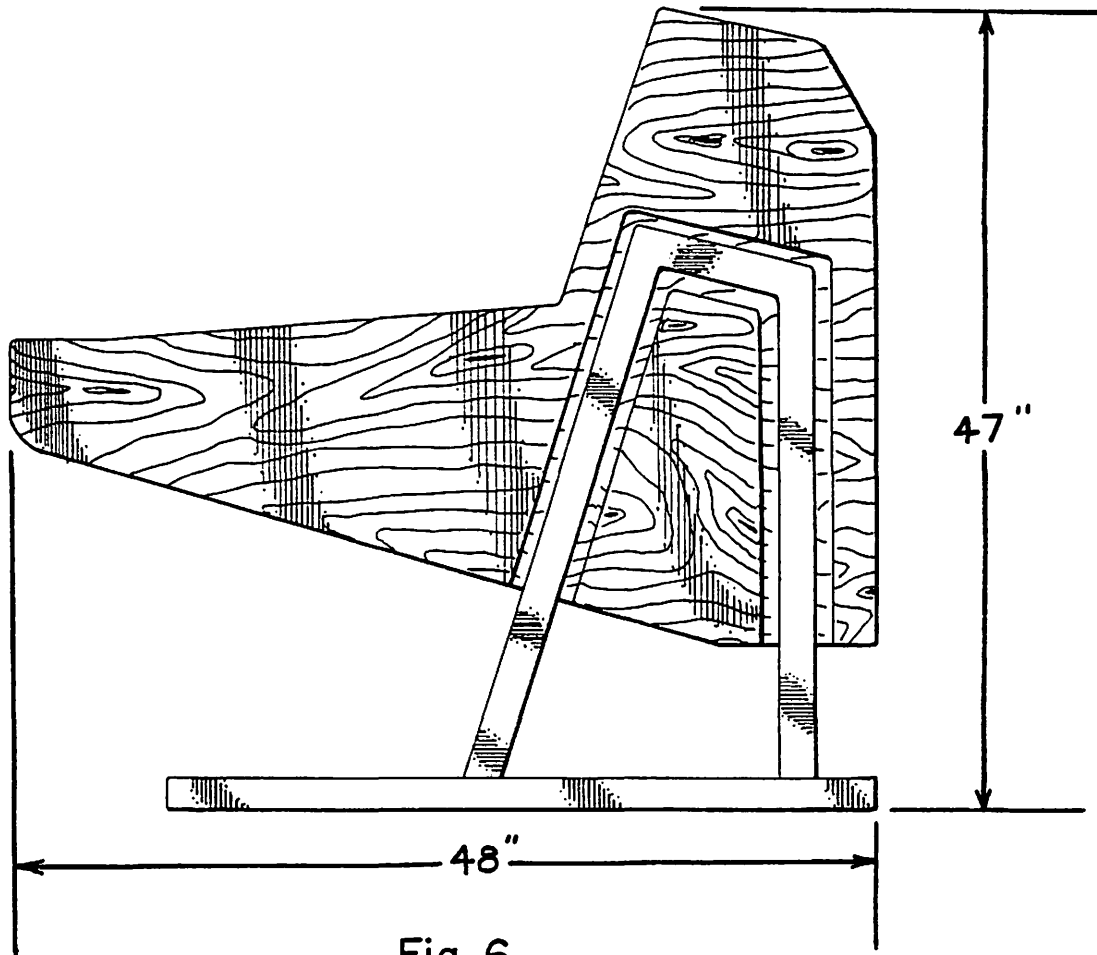

Fig. 6