

PROFESSIONAL SOUND EQUIPMENT

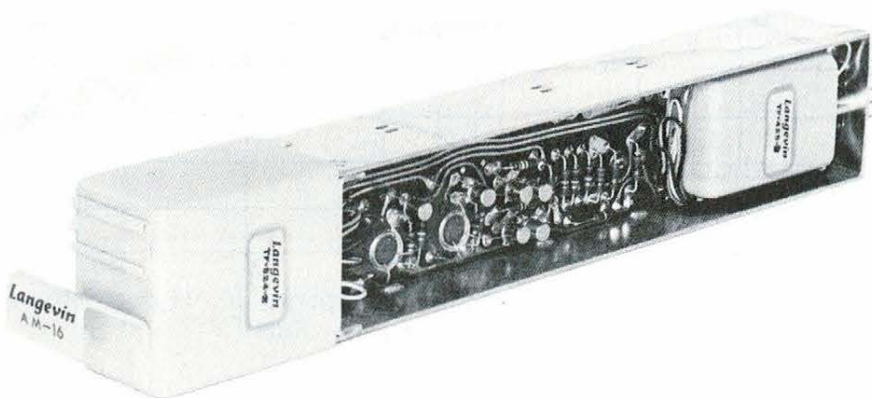

general description

The AM16 is primarily a microphone pre-mixing amplifier. However, its performance also qualifies it for use as a post-mixing (booster) and as a low-level program amplifier. Of special note is the very low noise generation figure (-127 dbm equivalent input, unweighted).

Extreme dependability has been stressed. All components are operated well within their ratings and no electrolytic capacitors or "chemical" parts have been used. All transistors are silicon planar NPN. The amplifier is not subject to damage from input or output overload or impedance mismatch.

Output power delivered to load is rated at +24 dbm, which may be reduced to +18 dbm by the omission of a strap connection. This lowers the supply current demanded from the external 24 v. DC source.

All conditional strapping of the amplifier whether for input impedance, output impedance, or output capability is performed on the mounting facility which receives it, and not on the amplifier proper. This allows complete interchangeability of all units within a given system without regard to their individual modes of employment.

architects' and engineers' specifications

The amplifier shall be Langevin AM16. It shall be plug-in. It shall have magnetically and electrostatically shielded input and output transformers. Input impedances shall be 50, 150 and 600 ohms. Output impedances shall be 150 and 600 ohms. All strapping for impedance and "high-low-power" shall be on the tray or cabinet which receives the amplifier, and not on the amplifier proper. Noise level shall not exceed an equivalent input of -127 dbm, unweighted. Gain at 1 Kc shall be 45 ± 0.5 db. When strapped for high power, harmonic generation at +24 dbm shall not exceed 0.75% from 30 cps to 20 Kc. When on low power, supply current demand shall be reduced, and harmonic generation at +18 dbm shall not exceed 0.5% from 30 cps to 20 Kc. Response at approx. +14 dbm shall be uniform ± 0.5 db from 20 cps to 20 Kc. Amplifier shall employ only silicon transistors, and no electron tubes. It shall not contain any electrolytic capacitors, nor any part with known shelf or service life. Size shall be approx. 1 3/4" high, 1 1/4" wide, and 10 1/2" long not including plug pins. Plug pins shall be gold-plated. Color scheme shall be gray and iridited cadmium plate.

The following graphs are included to show TYPICAL performance of the average AM16. Some variation may be expected from one unit to another. See page 4 for guaranteed performance of all units.

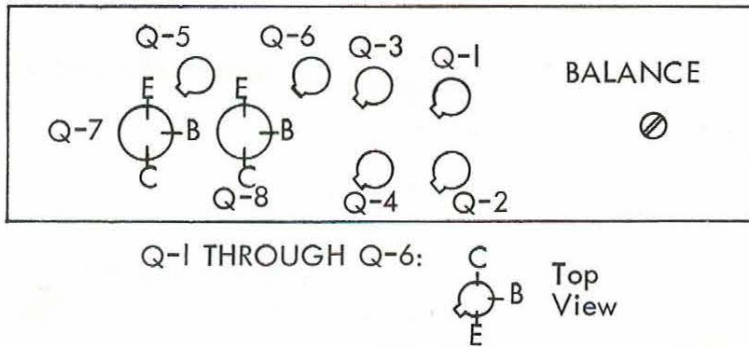
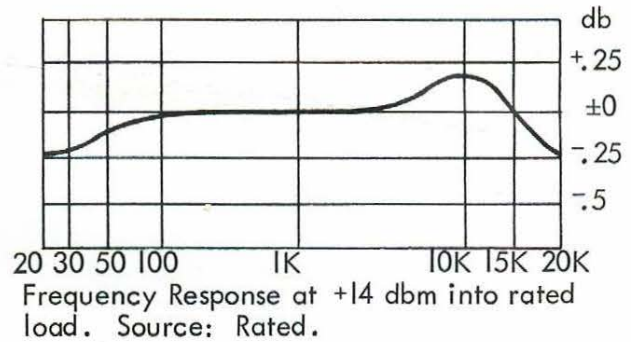
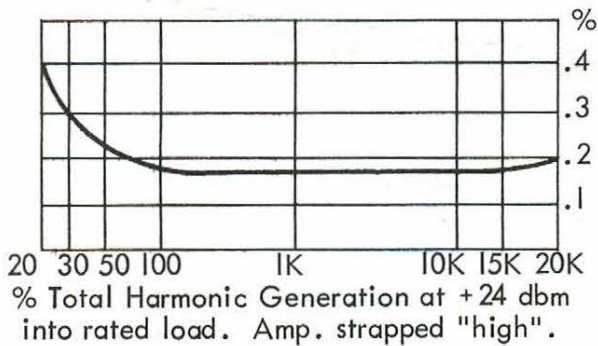

Adjust BALANCE control for minimum distortion at 30 cps. If distortion-measuring equipment is not available, adjust for zero voltage between the emitters of Q-5 and Q-6.

Q-1-2 (Langevin 1101) may be replaced with 2N929.

Q-3,4,5,6, (Langevin 1201 or 1401) may be replaced with 2N2897 or 2N3053).

Q-7,8 (Langevin 1401) may be replaced with 2N3053.

NOTE: Some early models of the AM 16 used TI-487 instead of Langevin 1401. Replace with TI487 from Texas Instruments).

VOLTAGES CHART: For no-signal. Amplifier strapped "high-power". Information is for use of 20,000 ohm-per-volt meter set for lowest practical scale. DC voltages only. All measurements are to minus polarity of 24 volt DC supply.

Q-1,2			Q-3,4			Q-5,6			Q-7,8		
E	B	C	E	B	C	E	B	C	E	B	C
.75	1.4	6.7	9.0	6.7	21.5	8.5	9.0	21.5	8.0	8.5	21.5

WARNING: Any attempt at unauthorized modification or repair which results in damage will void the "no repair charge" guarantee. It is suggested that any AM16 be returned to the factory untouched if it becomes defective within the guarantee period.

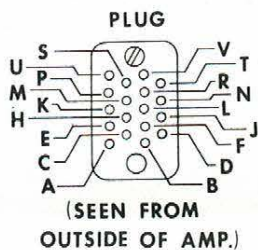
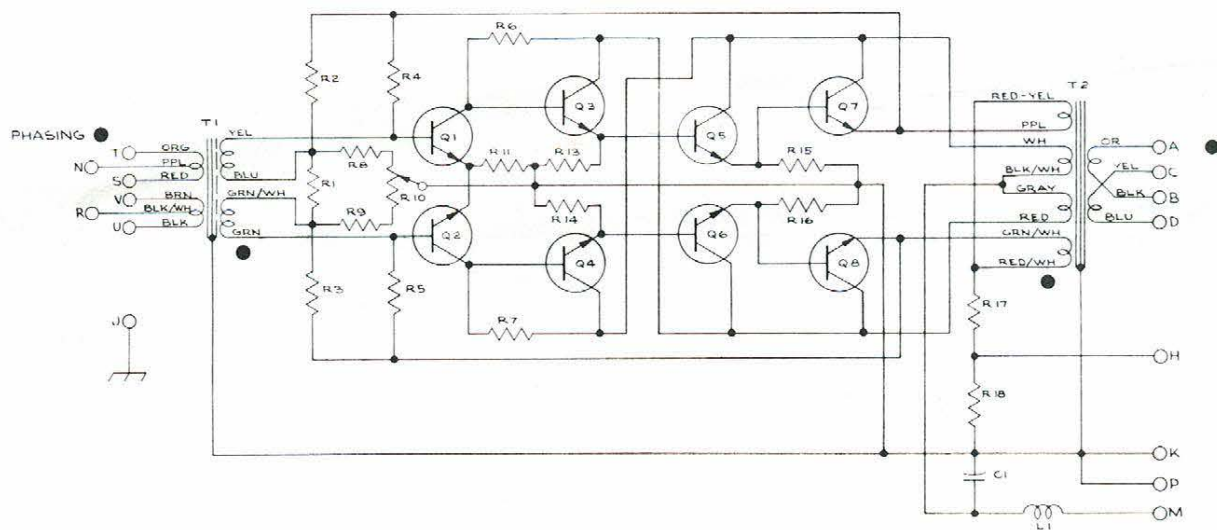

- Input 50 ohms: Connect to R and N. Strap S to V. There is no center tap available.
- Input 150 ohms: Connect to U and T. Strap U to S. Strap V to T. Strap R to N and use as center tap if desired.
- Input 600 ohms: Connect to U and T. Strap S to V. S or V may be used as center tap.
- Output 150 ohms: Connect to A and D. Strap A to C. Strap B to D. No c.t. available.
- Output 600 ohms: Connect to A and D. Strap C to B. C or B may be used as center tap.

If "high power" (+24 dbm output capability) is desired, strap H to K. Otherwise, omit the strap and the amplifier will work at "low power" (+18 dbm output capability).

C-1	.068 ufd	100 v	R-4	150 K	R-17	5l (2 watt)
L-1	220 uhy		R-5		R-18	130 (1 watt)
Q-1	L-1101 *		R-6	390 K	NOTE: All Resistors are 1/2 watt, 5% unless noted.	
Q-2			R-7		T-1	TF425*
Q-3			R-8	1.5 K	T-2	TF324*
Q-4	L-1201 *		R-9		* An asterisk denotes a Langevin part number. See page 2 for transistor types for field replacement purposes.	
Q-5			R-10	1 K lin. Pot.		
Q-6			R-11	15 K		
Q-7	L-1401 *		R-12	none used		
Q-8			R-13	100 K		
R-1	680		R-14			
R-2	10 K		R-15	10 K		
R-3			R-16			

Performance Figures Listed Below Are GUARANTEED Values.

GAIN: 45 ± 0.5 db
INPUT Z: 50, 150, 600 ohms
LOAD Z: 150, 600 ohms
HARMONIC GENERATION: (Total) *
Not Over 0.5% from 30 cps to 20 Kcps
@ +18 dbm (on "low-power").
Not Over 0.75% from 30 cps to 20 Kcps
@ +24 dbm (on "high-power").
NOISE GENERATION: Not over an input-
equivalent level of -127 dbm (measured
over bandwidth 20 cps to 20 Kcps).
FREQUENCY RESPONSE: ± 0.5 db from
20 cps to 20 Kcps (measured at approx.
+14 dbm output). *

* see page 2 for more detail

SIZE: Approx. $1\frac{3}{4}$ " high x $1\frac{1}{2}$ " wide
x $10\frac{1}{2}$ " long (not including plug
pins).
POWER REQUIREMENT: 24 v. DC (with
negative grounded). 110 ma when
on "high-power". 55 ma on "low".
ENVIRONMENTAL REQUIREMENT:
Temperature of mounting space must
not exceed 65°C (145°F), including
rise due to AM16/s. (Dissipation of
each AM16 is approx. 2 watts on
"high-power".

installation and operation

The installation of an AM16 consists of merely plugging it into its receptacle GENTLY.

Sources between 30 and 50 ohms should be connected to the 50 ohm input. Between 100 and 200 ohms, connect to the 150 ohm input. 250 to 600 ohms, use the 600 ohm input. (However, it is often possible to realize a few db of "noiseless" gain by the connection of a 250 ohm microphone to the 150 ohm input. Some loss of bass may be observed.)

Proper connector pins for desired input and output impedances may be found on page 2, as will strapping for "high-low-power". Because the AM16 is small in size, the mating connector solder lugs are also small. It will be found helpful to "bus" all power and then wire jumpers from the lugs to the buses.

A modern low-ripple power supply with good regulation must be used. Maintain voltage at 24 ± 2 volts. Do not allow development of any transients over 40 volts, or transistor damage may occur. Avoid noise by power-relays, etc., from separate supplies.

Install the AM16 in a position free from hum fields such as radiated by power transformers, chokes, modulation transformers, etc.

Do not allow environmental temperature to exceed 65°C (145°F).

Television synch pulse interference should not occur with the AM16, as the amplifier has a TV low-pass filter section in the internal power wiring. Also, the input transformer (in addition to being truly balanced), has triple magnetic shielding and full electrostatic screening. If TVI is encountered, please write to Langevin and describe in full all observations.

The negative side of the power supply must be grounded at one point, and only one point. This ground is usually located at the supply proper.

accessories

SEE LANGEVIN CATALOGUE (or request individual spec. sheets).

Mounting Tray no. TRY6 (for installation of single AM16 Amplifier).
Rack Cabinet no. RC612 (for installation of as many as 12 AM16 Amplifiers in $1\frac{3}{4}$ "
of vertical space in standard rack).
Power Supply no. PS217 (10 amperes).
Power Supply no. PS218 (3 amperes).

Langevin

503 S. GRAND AVENUE
SANTA ANA, CALIFORNIA

