

TYPE 119-A PROGAR AMPLIFIER
& POWER SUPPLY

INSTALLATION & OPERATING INSTRUCTIONS

LANGEVIN MANUFACTURING CORPORATION
37 West 65th Street
New York 23, N.Y.

No. 3777

PROGAR INSTRUCTION BOOK

T A B L E O F C O N T E N T S

Basic Operation.....2
Connections.....2
PROGAR Amplifier Chassis Controls (Figure 1).....4
Controls.....5
Vacuum Tube Gas Check.....5
Vacuum Tube Balance.....7
Input Level Adjustments.....8
Strapping Information for Input Attenuator.....9
Output Level Adjustments.....10
Alignment.....10
Dynamic Tube Balance.....12
Limiting Information.....13
Percentage Modulation.....13
Guardian Action Wait Time.....13
Limiter Release Time.....13
Guardian Increase Limit.....14

APPENDIX

Schematic Diagram - PROGAR Power Supply - Drawing #3498

Schematic Diagram - 119-A PROGAR Amplifier - Drawing #3184

INSTALLATION AND OPERATING INSTRUCTIONS FOR THE LANGEVIN
TYPE 119-A AMPLIFIER AND POWER SUPPLY

DESCRIPTION: The Langevin Type 119-A PROGAR amplifier is a combination fast acting peak limiter preceded by an automatic gain control amplifier with variable time constants. It is equipped with an associated semi-regulated power supply.

For installation purposes, the 119-A PROGAR amplifier can be considered as an amplifier of approximately 53 db gain, requiring a signal input of -31 VU and delivering an output level of +12 VU. These conditions are fixed. To adapt the PROGAR to the varied input and output levels found in station operation, fixed and variable attenuators are provided in the input and output circuits.

BASIC OPERATION

The Type 119-A PROGAR is a four stage push-pull amplifier. (See Drawing #3184) with the following sections:

Automatic Gain Control - This section is composed of the first push-pull stage of the main amplifier and control circuits consisting of a separate two stage push-pull amplifier, diode rectifier, diode memory circuit and conducting diode. The control circuits amplify and rectify the output voltage from the first push-pull stage of the main amplifier and apply this rectified voltage through the memory diode as a bias to the control and injector grids of the first push-pull stage.

Peak Limiter - This section is composed of the last three push-pull stages and a biased diode rectifier connected across the output. The diode rectifies a portion of the output voltage whenever that voltage exceeds a predetermined amount and applies that rectified voltage as a bias to the control and injector grids of the limiter input stage.

The 119-A Power Supply is semi-regulated. It is used to supply plate current, filament power, and pilot lamp voltage to the 119-A PROGAR amplifier. Because variations in line voltage will allow slight variations in the signal level at the point when limiting action begins, it is recommended that the power supply be connected to the same AC power source as the transmitter modulator. Thus, as variations in AC power affect the modulator, a compensating action will occur in the PROGAR.

CONNECTIONS

I. PROGAR AMPLIFIER (see Drawing #3184)

- a) Connect the Input to the PROGAR to terminals 1 and 2.
- b) Connect the Output terminals 4 and 5 to the line.
- c) Connect terminal 3 to Ground.
- d) If one side of the Input line is grounded, connect that ground lead to terminal 2.

I. PROGAR AMPLIFIER (cont.)

- e) If one side of the Output line is grounded, connect that ground lead to terminal 5.
- f) Connect terminals 8 to 15 (Drawing #3184) inclusive on the PROGAR amplifier to terminals 8 to 15 on the power supply. (Drawing #3498)

*Note: An interconnecting cable is supplied for the connections to be used when the PROGAR amplifier and power supply are mounted together in a rack. If desired, the power supply can be located at a remote point, in which case use an eight wire cable (not supplied). Filament power (approximately 6.5 amperes) must be supplied through one pair in the cable.

II. PROGAR POWER SUPPLY (See Drawing #3498)

- a) For 105-115 volt operation, the tap marked "110" on the power transformer should be used.
- b) For 115-125 volt operation, the tap marked "120" on the power transformer should be used.
- c) Connect terminals 16 and 17 to a power source capable of supplying 150 watts at 105 to 125 volts AC, single phase, 60 cycles.

FUSTAT

The PROGAR unit is protected by a 2.5 ampere Buss Fustat which is located on the Power Supply chassis. Ambient temperature has a direct effect on the operating characteristics of Fustats. The rating of a Fustat is based on its ability to carry a certain load at 70° Fahrenheit. Lower temperatures would have the effect of increasing the carrying capacity, whereas higher temperatures would decrease the carrying capacity. Therefore, if the Fustat should open because of high ambient temperature in the rack, it is an indication that additional ventilation must be provided.

After proper connections have been made, place the mat panels on the PROGAR amplifier and power supply making sure that the meter plug has been inserted in the PROGAR amplifier. (The extension meter cable is provided for ease in servicing the PROGAR).

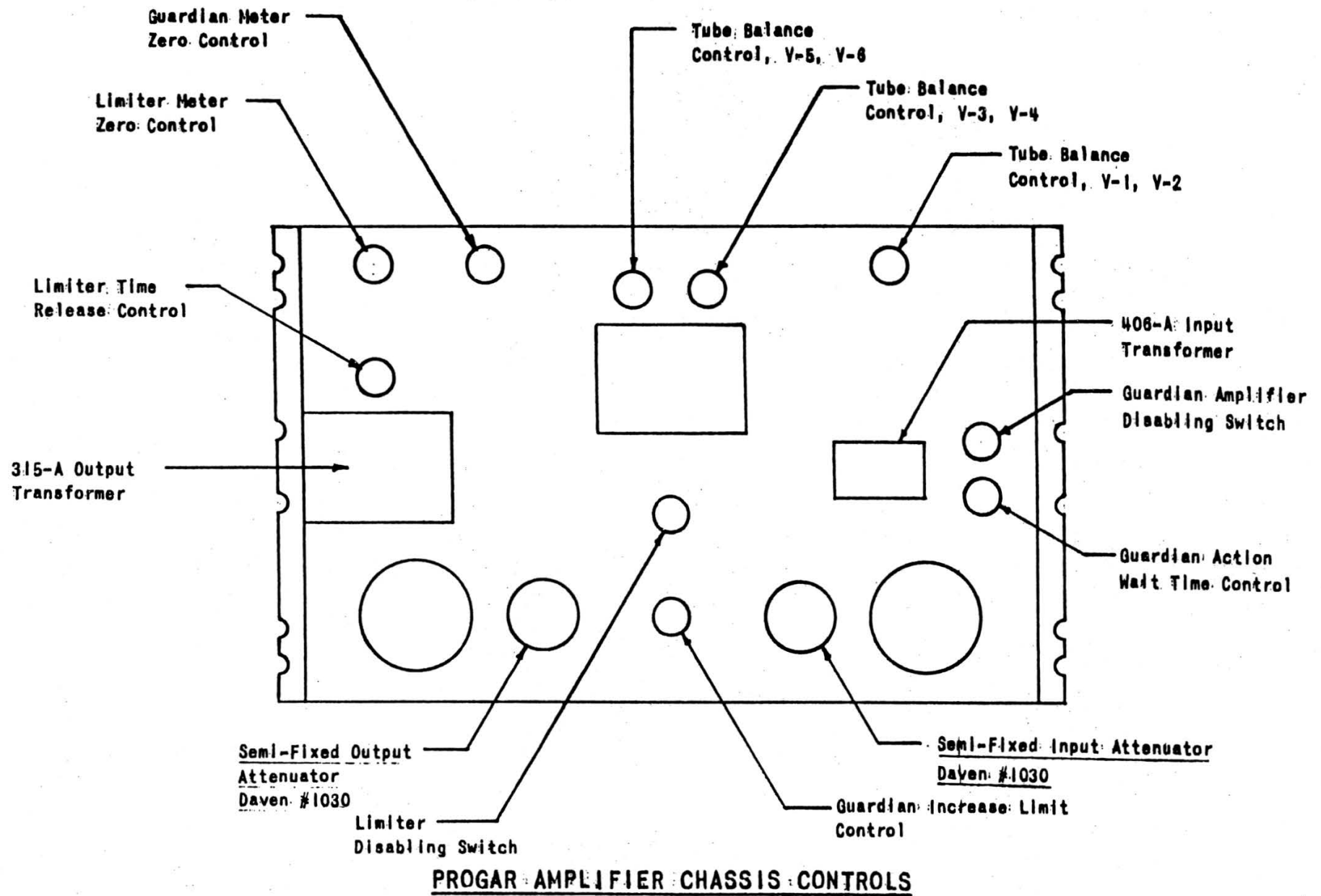

Figure 1

CONTROLS

Set the PROGAR controls as follows:

Front Panel Controls

	<u>Setting</u>
Input Attenuator	Half scale (8)
DB Limiting	0
Metering	LIM
Output Attenuator	Half scale (2)

Chassis Controls (see Figure 1)

	<u>Setting</u>
Limiter Meter Zero Control	Full clockwise
Guardian Meter Zero Control	Full clockwise
Limiter Time Release Control	1.2 sec.
Limiter Action Switch	Disabled
Guardian Increase Limit Control	45
Guardian Action Switch	Disabled
Guardian Wait Time Control	.6 sec.
Tube Balance V-1, V-2	Half scale
Tube Balance V-3, V-4	Half scale
Tube Balance V-5, V-6	Half scale

VACUUM TUBES

The vacuum tubes shipped with PROGAR have been tested and matched at the factory for proper operation of the unit.

However, because of possible rough handling during shipment, it is advisable to recheck tubes in accordance with the following procedure before the PROGAR is placed in operation.

VACUUM TUBE GAS CHECK

It is important that the PROGAR tubes be relatively free from gas because of the extremely high resistance of the grid circuits. The grid to cathode resistance of tubes V-1 and V-2 is the leakage resistance of condenser of C-22 which is approximately 2000 megohms. The grid to cathode resistance of tubes V-3 and V-4 varies from 2 to 12 megohms, depending upon the setting of the Limiter Wait Time Switch. Gassy tubes cause a decrease in the attack time of the guardian circuit, "blooping" in the limiter circuit and also can cause overshooting (holes in program material) in the guardian and limiter circuits.

VACUUM TUBE GAS CHECK
(continued)

I. Check the four 1612 vacuum tubes (used in sockets V-1, V-2, V-3, and V-4) as follows:

- a) Insert all tubes except 1612's and 6H6's in proper sockets.
- b) Insert two 1612 tubes in tube sockets V-3 and V-4.
- c) Turn on power switch and allow at least 5 minutes for the PROGAR to warm up.
Caution: Plate voltage is exposed in the PROGAR amplifier and power supply when the mat panels are not in position.
- d) Recheck "Limiter Action Switch", making sure it is in the "disabled" position.
- e) Place the Metering Switch (front panel) at LIM and adjust the Limiter Meter Zero Control (rear of chassis, see Figure 1) so that the Limiter Meter reads zero. (Full deflection to right.) This meter is used for checking tubes as well as for showing limiter action.
- f) Balance the plate currents of the two 1612 tubes (V-3 and V-4) using the Tube Balance Control for V-3, V-4 (rear of chassis, see Figure 1).

<u>Metering Switch Position</u>	<u>Vacuum Tubes</u>
#3	V-3
#4	V-4

- g) Place the Metering Switch on the LIM position.
- h) Turn the Limiter Action Switch "ON" and "OFF" several times while observing the Limiter Meter. (Allow a few seconds for a gassy condition to show.) If the meter needle moves more than 1/16" below zero (to the right), one of the 1612 tubes is gassy and must be replaced.
Note: Before substituting a new 1612 tube, this tube must be balanced with the remaining tube in accordance with steps d and f.
- i) Repeat this tube check until four 1612 tubes have been found that are not gassy.

II. Check the four 6H6 vacuum tubes as follows:

- a) With two non-gassy 1612 tubes in sockets V-3 and V-4, insert a 6H6 tube in tube socket V-14.
- b) With the "Limiter Action Switch" in the ON position turn the Limiter Meter Switch to the LIM position. If the meter needle moves more than 1/16" away from zero as indicated in the previous test, the 6H6 tube is gassy and must be replaced.
- c) Repeat this check until four non-gassy 6H6 tubes have been selected.

VACUUM TUBE BALANCE

After selecting "gas free" tubes, place all tubes in their proper sockets and allow at least five minutes for the PROGAR to warm up. After the warm-up period adjust the Limiter Meter Zero Control so that the Limiter Meter reads zero and adjust the Guardian Meter Zero Control so that the Guardian Meter reads zero. (Zero controls are located at the upper right, rear of chassis. See Figure 1)

Check the plate currents of all the amplifying tubes in the PROGAR by turning the Metering Switch through positions 1 to 14. Tube plate currents are read on the lower scale of the Limiter Meter and all plate currents should read inside the "Tube Check" area (not critical in the last four positions). Caution: No tone or signal is to be applied during this check.

In meter positions 1 and 2, balance the plate current readings of tubes V-1 and V-2; in positions 3 and 4, balance V-3 and V-4; and in positions 5 and 6, balance V-5 and V-6. If unable to obtain a balance, substitute other tubes. Note: 1612's must be gas checked.

These three vacuum tube stages must be well balanced for proper operation of the controlled stages. An unbalance may result in "blooming" during limiter and guardian operation.

DEFINITIONS

DBM.....Decibel level measurement with reference to one milliwatt, single frequency sine wave tone.

VU.....Power level of a complex wave (as found in speech and music) as indicated by a standard VU meter.

For installation purposes, the 119-A PROGAR amplifier can be considered as an amplifier of approximately 53 db gain, requiring a signal input of -31 VU and delivering an output level of +12 VU. These conditions are fixed. To adapt the PROGAR to the varied input and output levels found in station operation, fixed and variable attenuators are provided in the input and output circuits.

INPUT LEVEL ADJUSTMENTS

The level required on the primary of the input transformer for proper PROGAR operation is approximately -31 VU.

An adjustable and a semi-fixed attenuator are provided in the circuit ahead of the input transformer, to compensate for the various line levels encountered in broadcast and recording studio operation. The variable attenuator is located on the front panel of the PROGAR and has a range of 15 db in .5 db steps. The semi-fixed attenuator (Daven #1030) is located under a dust cover on the rear of the PROGAR chassis (see Figure 1 for exact location) and can be strapped for any attenuation from 1 to 40 db in steps of 1 db. This attenuator is not connected at the factory and must be connected at installation time in accordance with the anticipated line level (see Figure 2, Page 9, for strapping information).

Attenuator adjustments at the PROGAR input to obtain a level of -31 VU on the primary of the input transformer

Variable Input Attenuator (located on front panel):
Set at approximately center of scale (8 db) to allow for future minor adjustments.

Semi-Fixed Attenuator (Daven #1030 located on rear of chassis -- see Figure 1):
Strap this attenuator in accordance with following table and diagram.

Note: The Daven #1030 semi-fixed attenuator shown in "A" is composed of a series of six fixed "T" pads for 1, 2, 3, 4, 10 and 20 db attenuation which can be connected in series in any combination from 1 to 40 db in steps of 1 db.

Typical input levels (shown in column 1 below) are used for illustration purposes --- other input levels to the PROGAR can be attenuated* by following general instructions.

**For proper operation of the PROGAR, the level on the primary of the input transformer should be -31 VU.*

A) Pad shown strapped for 15 db.

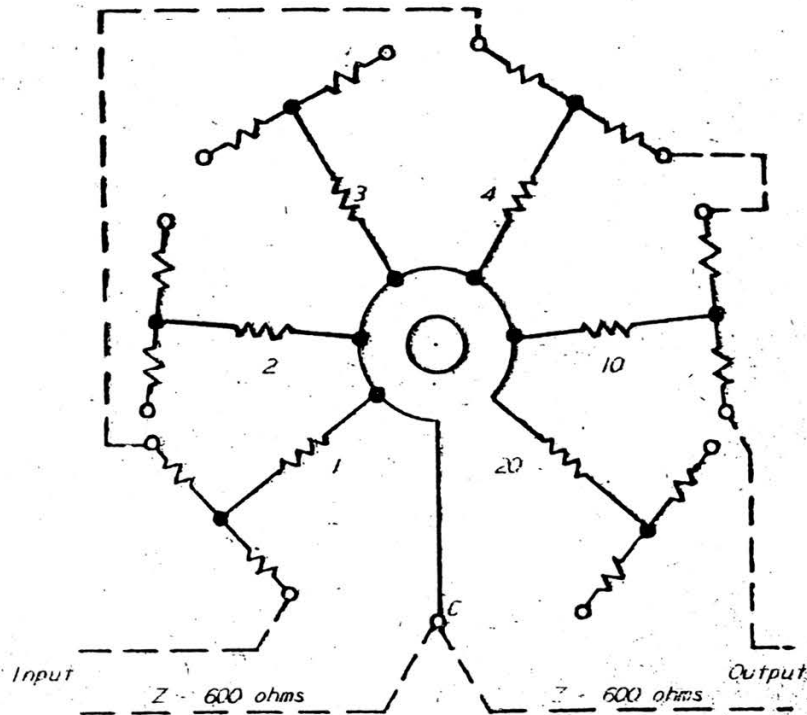

INPUT LEVEL AT PROGAR INPUT TERMINALS	ATTENUATION REQUIRED IN SEMI-FIXED INPUT ATTENUATOR WITH VARIABLE INPUT ATTENUATOR SET AT 8 DB	STRAPPING DETAILS FOR DAVEN #1030 PAD Connect:
-23 VU	0	---
-16 VU	7 db	3 & 4 db pads
- 8 VU	15 db	1, 4 & 10 pads
0 VU	23 db	3 & 20 db pads
+8 VU	31 db	1, 10 & 20 pads
+16 VU	39 db	2, 3, 4, 10 & 20 db pads

Figure 2

OUTPUT LEVEL ADJUSTMENTS

The output level, on the secondary of the PROGAR output transformer at the threshold of limiting, is approximately $\sqrt{12}$ VU.

To attenuate this output level, a variable and a semi-fixed attenuator are provided in the circuit following the output transformer. The variable output attenuator is controlled from the front panel and has a range of 4.5 db in steps of .1 db. This attenuator has zero insertion loss when the dial is set at zero. The semi-fixed attenuator is located under a dust cover at the rear of the chassis (see Figure 1) and can be strapped for a total attenuation of 40 db in steps of 1 db. (See Figure 3 for strapping information.) The semi-fixed attenuator is not connected at the factory and must be connected at the time of installation in accordance with the output level desired.

It is recommended that at least 6 db attenuation be utilized for isolation purposes.

Figure 3

ATTENUATOR ADJUSTMENTS AT THE PROGAR OUTPUT TO OBTAIN DESIRED OPERATING LEVEL FROM A BASE OF $\sqrt{12}$ VU

- I. Variable output attenuator: Set at "2 db" to allow for future minor adjustments.
- II. Strap semi-fixed output attenuator (Daven #1030) in accordance with information found in Figure 2. (Instructions for strapping input and output pads are identical.)

IMPORTANT NOTE:

Measurements (after attenuator adjustment) made with a single frequency tone (DBM) will be approximately 10 DB higher than the corresponding VU reading. (See VU and DBM definitions.) Therefore, if the attenuators are adjusted with a single frequency tone, the complex signal output will be approximately 10 DB lower and the semi-fixed output attenuator should be strapped with 10 DB less attenuation.

ALIGNMENT

Recheck PROGAR controls in accordance with the following settings before proceeding with further alignment.

<u>Front Panel Controls</u>	<u>Setting</u>
DB Limiting	0
Metering	LIM
<u>Chassis Controls (see Figure 1)</u>	
Limiter Time Release	.6 sec.
Limiter Action Switch	DISABLED
Guardian Increase Limit Switch	$\sqrt{5}$
Guardian Action Switch	DISABLED
Guardian Action Wait Time Control	.6 sec.

- I. Place the Limiter Action and Guardian Action switches in the "ON" position. After a warm up period of from 6 to 13 seconds, the Guardian Meter should read /5. (This value has been set by the "Guardian Increase Limit Control".)
- II. Connect a 1000 cycle source to the input terminals 1 and 2. Connect a VU meter with a 600 Ohm resistive termination to the output terminals 4 and 5. The 1000 cycle tone applied to the input terminals should correspond to the average peak program level. If the input attenuators have been adjusted properly, the Guardian Meter should read zero.

If the Guardian Meter does not zero:

- a) Adjust the variable input attenuator on the front panel.
- b) Restrap the fixed input attenuator (Daven #1030) on the rear of chassis, to produce desired input level (-31 VU) on primary of input transformer.

IMPORTANT NOTE:

If the level on the input transformer is too high, it will be necessary to disconnect the 1000 cycle tone after each adjustment until the Guardian Meter returns to the /5 position.

If the level is too low, this precaution will not be necessary.

- III. When the 1000 cycle tone is applied, the VU meter connected on the output terminals should indicate an output level corresponding to 10 db higher than the level required for 80% modulation of the radio transmitter.

IMPORTANT NOTE:

Because of the standard VU meter's ballistic characteristics instantaneous peaks in program material are not indicated. It has been found that there is a difference of from 6 to 14 db between the peak value of the program material and the volume level indicated on the VU meter. To compensate for this difference, when making alignment adjustments on the PROGAR, it is suggested that a difference of 10 db be used to distinguish the test signal and average peak program material.

If the VU meter does not indicate the required output level:

- a) Adjust the variable output attenuator located on the front panel.
- b) Restrap the output attenuator if the range of the variable attenuator is not sufficient to compensate for the discrepancy.

To allow for future operating adjustments, it is desirable that the variable output attenuators be as near mid-position as possible. Therefore, it is recommended that the alignment procedure be repeated until proper values have been strapped to enable the variable attenuator to remain in mid-position.

DYNAMIC TUBE BALANCE

After final adjustment of fixed input and output attenuators, it has been found advisable to recheck the vacuum tubes in the peak limiter section of the PROGAR for dynamic balance as follows:

- I. Place the PROGAR in operation.
 - a) Disable Guardian.
 - b) Place Limiter on.
 - c) Apply a 1000 cycle tone so that the Guardian Meter reads zero.
- II. Rotate the DB Limiting Control knob clockwise until the Limiter Meter indicates approximately 10 db of limiting.
- III. Check the balance of vacuum tubes, V-3, V-4 (on Limiter Meter) with the limiting control in the 10 db position. (Use Tube Balance Control V-3, V-4, rear of chassis, see Figure 1). Because the tubes are limiting, the needle on the tube check scale will not indicate in the black portion, but will indicate about half scale or below.

Note:

Tube balance under limiting conditions is critical in order to prevent "blooming" of the program material. An accurate balance at zero, however, is important. The balance at zero should fall within 1/64" of the tube balance indication when the tubes are limiting.

FOLLOWING THE RECHECK OF THE TUBE BALANCE UNDER LIMITING CONDITIONS, THE EQUIPMENT IS READY FOR USE.

Limiting

With the DB Limiting Switch in the zero position all program peaks above the average peak level (approximately 10 to 14 db above the average program level) are compressed. This action can be observed on the Limiter Meter with the Metering Switch in the "LIM" position. Under some circumstances, more limiting may be desired. This can be accomplished by turning the DB Limiting Switch clockwise. Each position of the switch causes limiting to occur approximately 2 db closer to the average program level. A suggested compromise for all types of program material is approximately 6 db of limiting.

Percentage Modulation

If it is desired to increase the maximum modulation level as observed on a Cathode Ray Oscilloscope, it is readily possible by adjusting the variable output attenuator on the front panel of the PROGAR. The average modulation can be increased further by rotating the DB Limiting Switch clockwise.

Guardian Action Wait Time

The period of time before the Memory Circuit in the PROGAR begins to increase the gain of the Guardian amplifier, after a decrease in program level, can be adjusted with the GUARDIAN ACTION WAIT TIME SWITCH from 2 to 8 seconds in steps of 2 seconds, (see Figure 1).

It has been found that a 6 second "wait time" represents a reasonable compromise value to insure effective increase in signal strength, while at the same time preserving dynamic expression of the program material.

Limiter Release Time

The Limiter "attack time" is fixed. The PROGAR peak limiter "release time" is adjustable with the LIMITER TIME RELEASE switch from .2 seconds to 1.2 seconds in .2 second steps (see Figure 1). The release time is the time required for limiter gain to return to normal after a peak has passed. A setting of .6 second is recommended.

Guardian Increase Limit

The "Guardian Increase Limit Switch" adjusts the maximum gain of the Guardian Circuit in steps of 5 db from 0 to 15 db (see Figure 1).

Guardian Increase Limit (cont.)

The setting of this control indicates the amount of drop in average program level for which the Guardian will compensate (after the "wait time" has elapsed).

With normal manual program monitoring, the Guardian Increase Limit Switch can be left in the /5 position. This will limit the gain increase of the automatic gain control amplifier (Guardian) to 5 db above normal gain.

If the noise level of the other audio equipment in the system preceding the PROGAR is sufficiently low, this control can be set for a /10 or /15 db guardian increase on decreases in program level. This setting is desirable if the PROGAR is used at unattended locations.

No limit control is provided on the "gain decrease" action of the automatic gain control amplifier (Guardian). The Guardian will compensate for increases in program level up to 20 db.

REVISIONS
 REVISED, REMOVED
 POWER SUPPLY
 AND REDRAWN
 ISSUE # 7 10-15-46
 W.N.M. PS
 CHANGED VALUE
 OF R-42, ADDED
 C-22B AND
 VOLTAGES
 ISSUE # 11-2-47
 W.N.M. PS

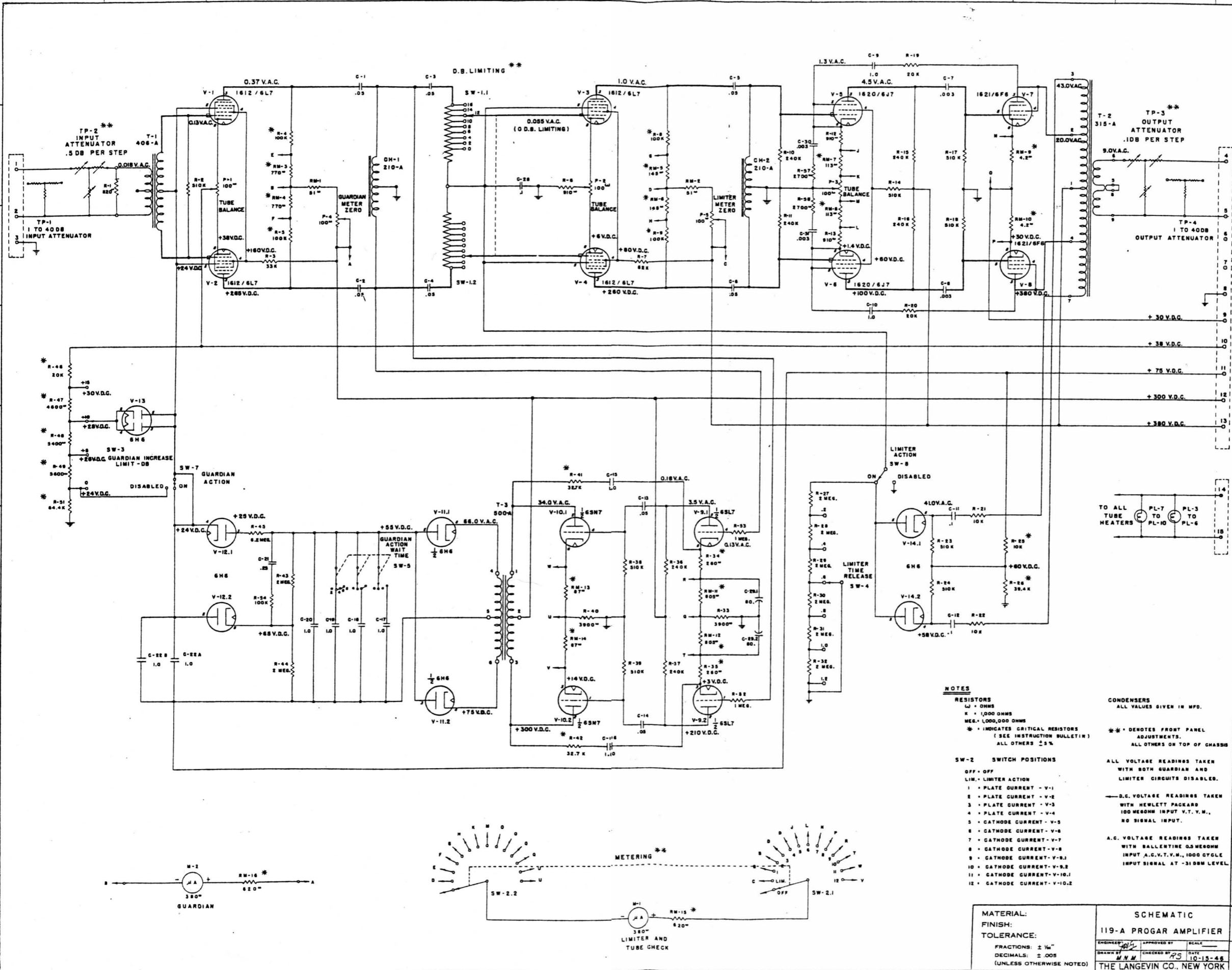

NOTES
RESISTORS
 L_J = OHMS
 K = 1,000 OHMS
 MEG. = 1,000,000 OHMS
 * = INDICATES CRITICAL RESISTORS
 (SEE INSTRUCTION BULLETIN)
 ALL OTHERS ± 5%
CONDENSERS
 ALL VALUES GIVEN IN MFD.
 ** = DENOTES FRONT PANEL
 ADJUSTMENTS.
 ALL OTHERS ON TOP OF CHASSIS
SW-2 SWITCH POSITIONS
 OFF - OFF
 LIM. - LIMITER ACTION
 1 - PLATE CURRENT - V-1
 2 - PLATE CURRENT - V-2
 3 - PLATE CURRENT - V-3
 4 - PLATE CURRENT - V-4
 5 - CATHODE CURRENT - V-5
 6 - CATHODE CURRENT - V-6
 7 - CATHODE CURRENT - V-7
 8 - CATHODE CURRENT - V-8
 9 - CATHODE CURRENT - V-9
 10 - CATHODE CURRENT - V-10
 11 - CATHODE CURRENT - V-10.1
 12 - CATHODE CURRENT - V-10.2
**ALL VOLTAGE READINGS TAKEN
 WITH BOTH GUARDIAN AND
 LIMITER CIRCUITS DISABLED.**
**D.C. VOLTAGE READINGS TAKEN
 WITH HEWLETT PACKARD
 100 MEGOHM INPUT V.T. V.M.,
 NO SIGNAL INPUT.**
**A.C. VOLTAGE READINGS TAKEN
 WITH BALLENTINE 0.5 MEGOHM
 INPUT A.C.V.T.V.M., 1000 CYCLE
 INPUT SIGNAL AT -31DBM LEVEL**

(3498)
 ASSOC. DWGS.

MATERIAL: FINISH: TOLERANCE: FRACTIONS: ± 1/16" DECIMALS: ± .005 (UNLESS OTHERWISE NOTED)	SCHMATIC 119-A PROGAR AMPLIFIER APPROVED BY: [Signature] SCALE: DATE: 10-15-46 THE LANGEVIN CO., NEW YORK	NOTE DO NOT SCALE DRAWING WORK TO DIMENSIONS DRAWING NO. 3184
--	--	--

REVISIONS

C26 RELOCATED

ISSUE 2	DATE 8-19-47
REV BY <i>GLM</i>	CHE BY <i>RS</i>

REVISED VALUES ON TS-4

ISSUE 3	DATE 11-3-47
REV BY <i>GLM</i>	CHE BY <i>RS</i>

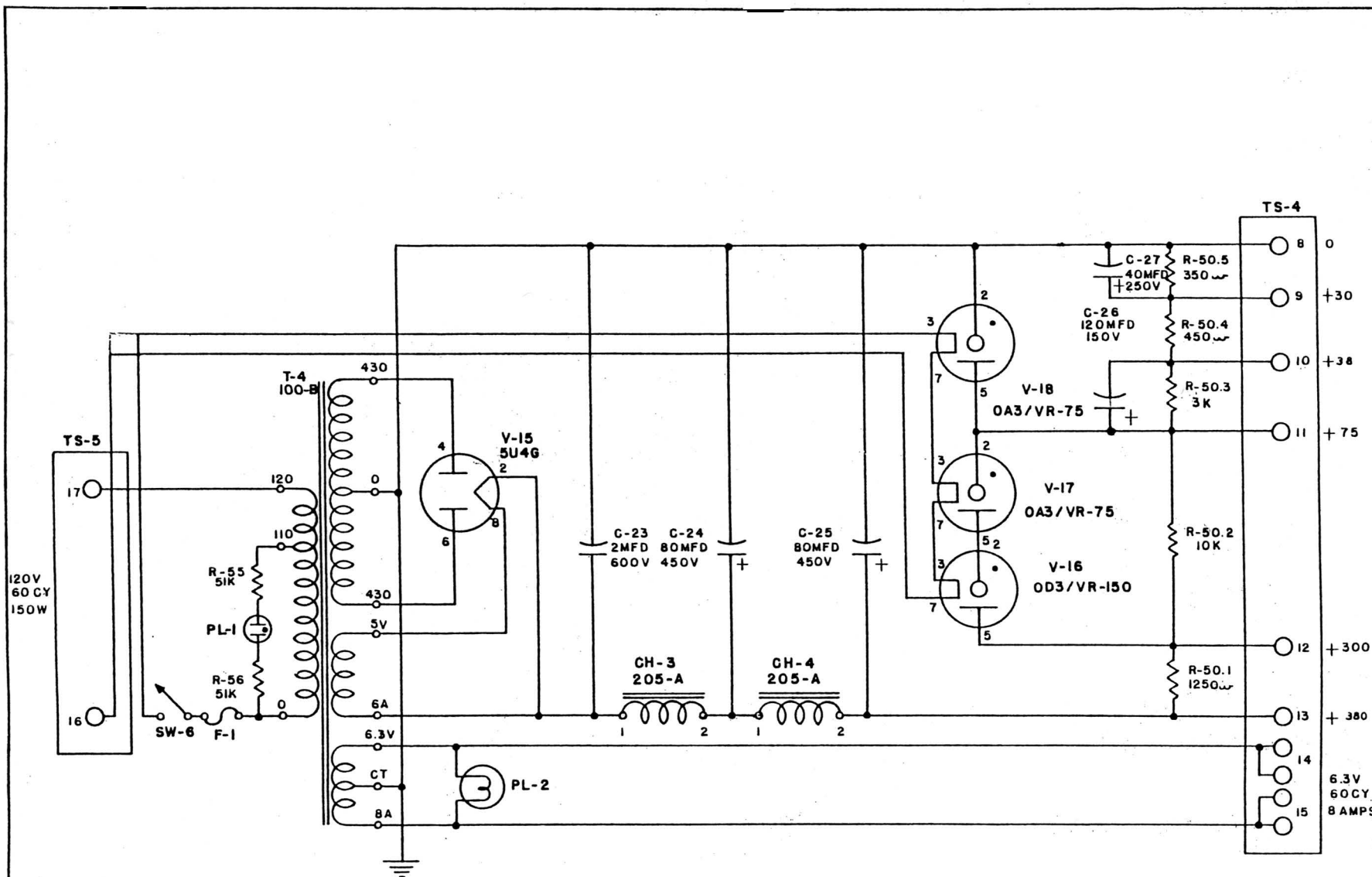

3184

ASSOC. DWGS.

MATERIAL:
FINISH:
TOLERANCE:
FRACTIONS: $\pm \frac{1}{64}$ "
DECIMALS: $\pm .005$
(UNLESS OTHERWISE NOTED)

SCHEMATIC DIAGRAM
POWER SUPPLY
119-A PROGAR

ENGINEER <i>GLM</i>	APPROVED BY	SCALE
DRAWN BY <i>GLM</i>	CHECKED BY	DATE 7-14-47
THE LANGEVIN CO., NEW YORK		

NOTE
DO NOT SCALE
DRAWING WORK
TO DIMENSIONS

DRAWING NO.
3498