

**pete cornish
musical
accessories**

**unit 306,
164/180 union street,
london, SE1 OLH.
tel: 01 928 2670.**



4 IN : 8 OUT AUDIO SWITCHING MATRIX.

S/No: 233 JULY 1992.

INPUT #1

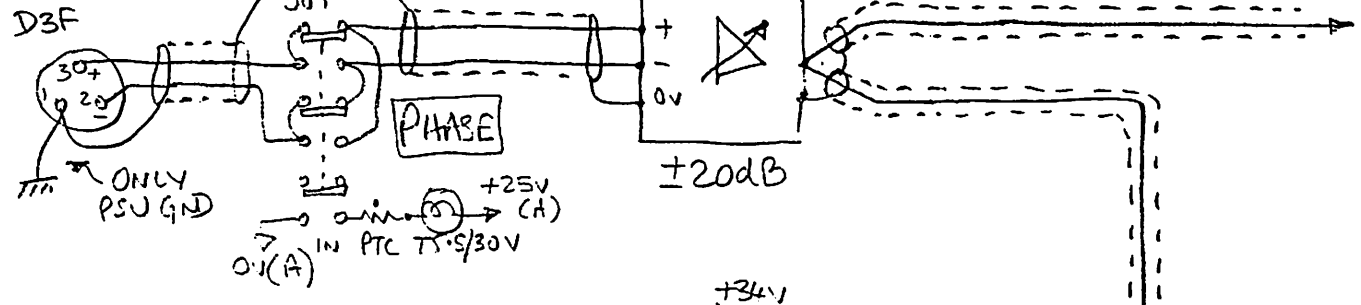

INPUT #2

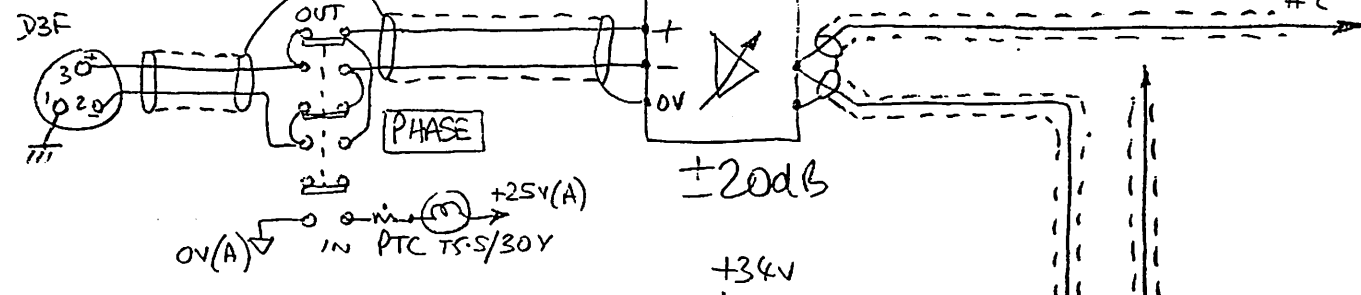

INPUT #3

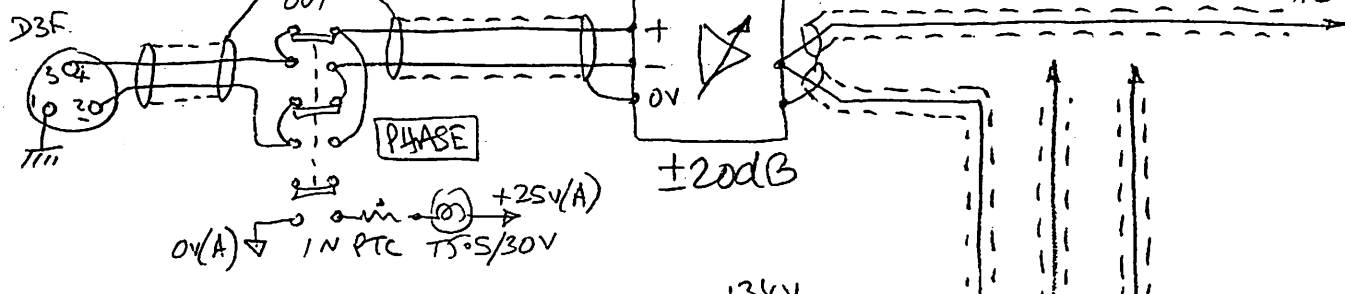

INPUT #4

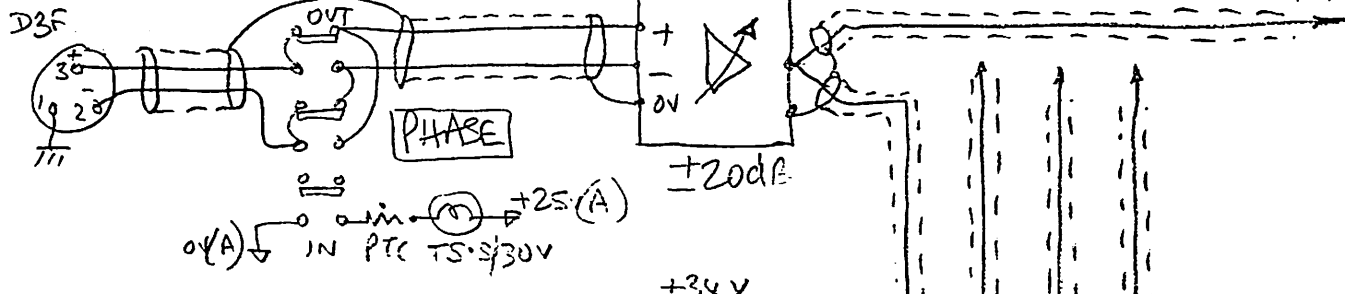

0 = -10dBm

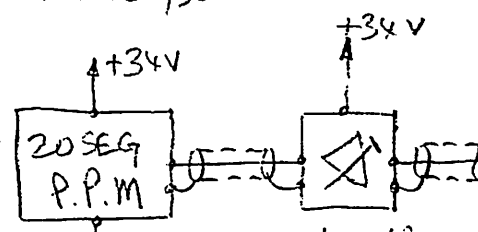

ALL PHASE SW'S:

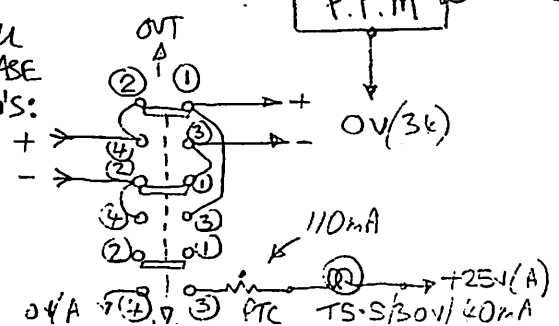

READ INPUT 1-4

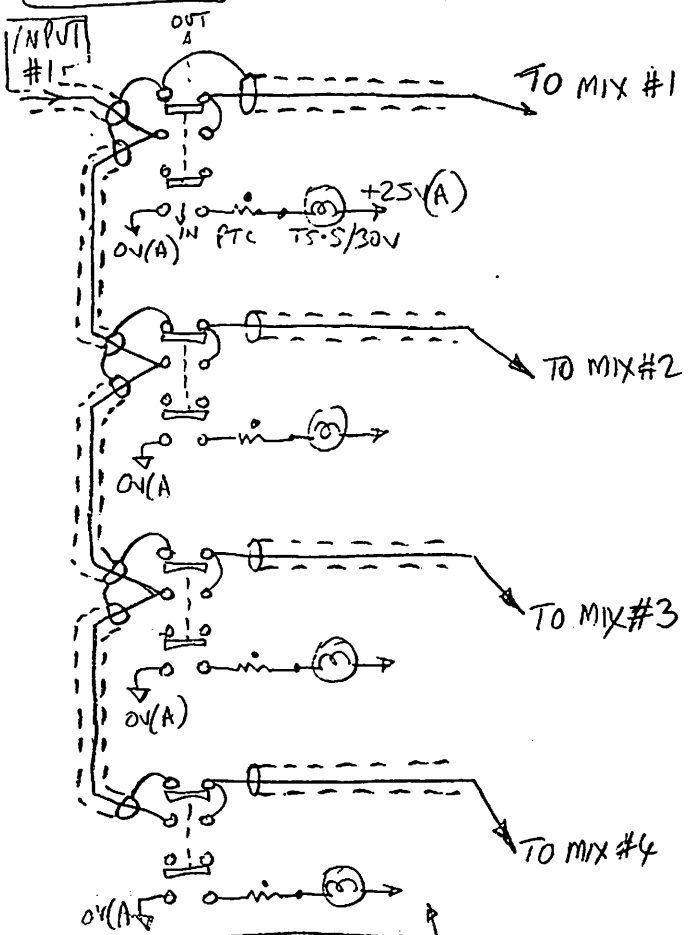

INPUT #1 ASSIGNMENT

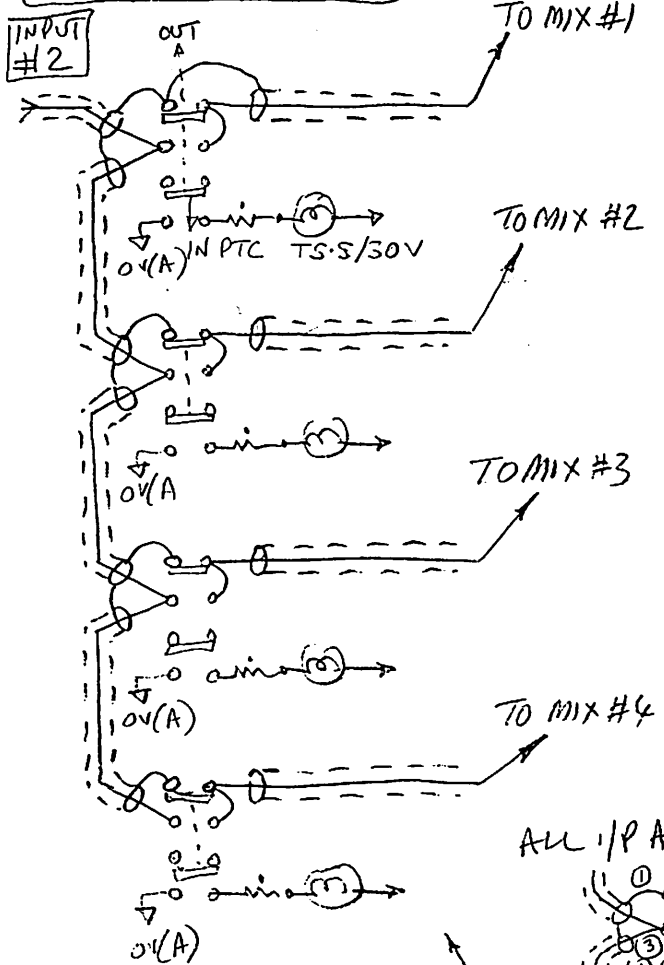

INPUT #2 ASSIGNMENT

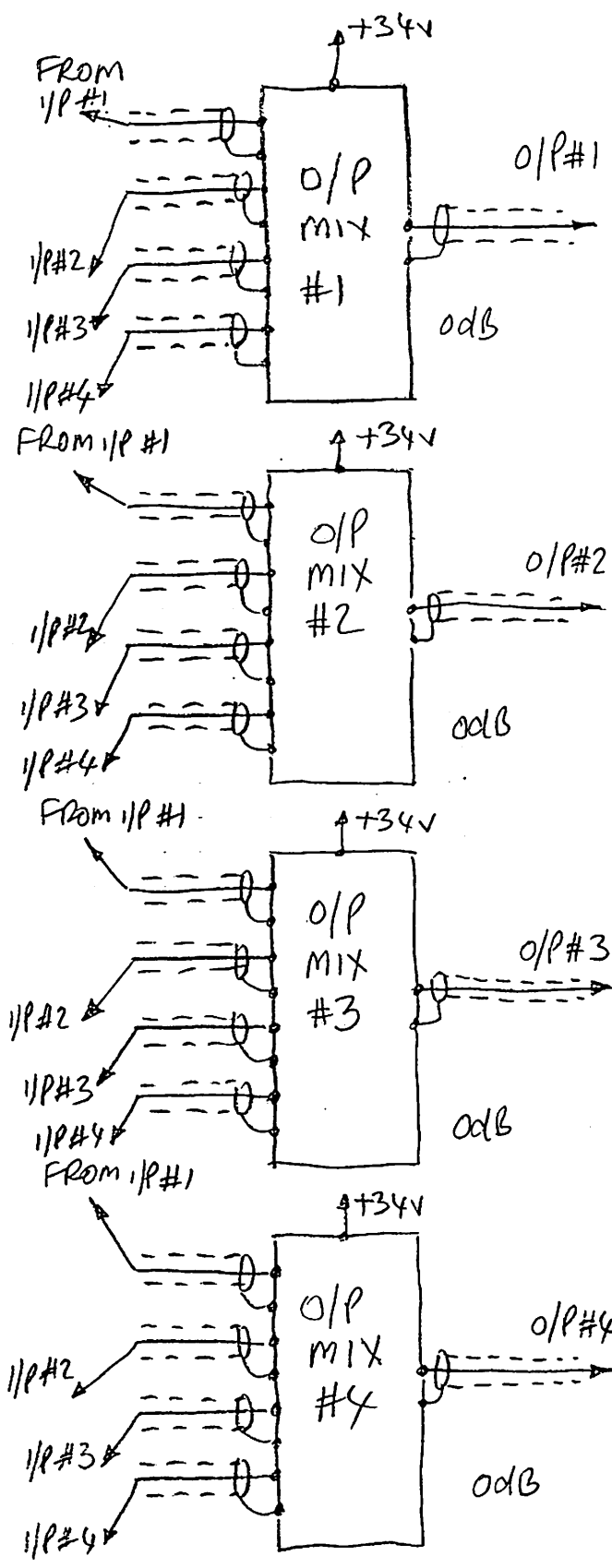

ALL I/P ASSIGN SWITCHES:

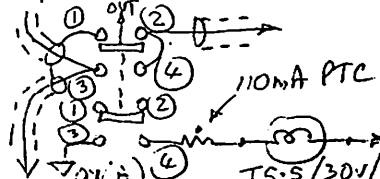

NB: INPUT #3 + #4 ASSIGNMENT SW! AS #1 AND #2.

FROM
O/P MIX'S

#1

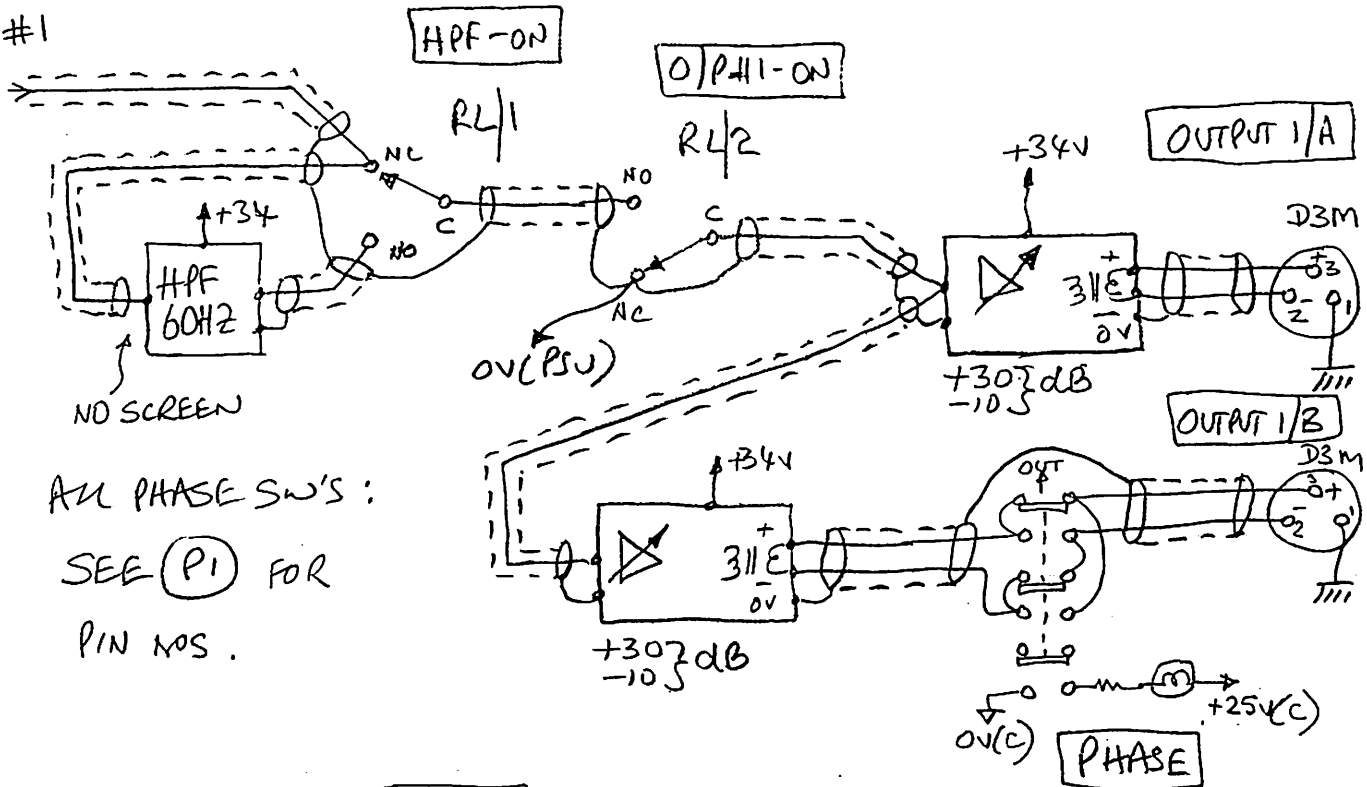

ALL PHASE SW'S :
SEE (P1) FOR
PIN NOS.

#2

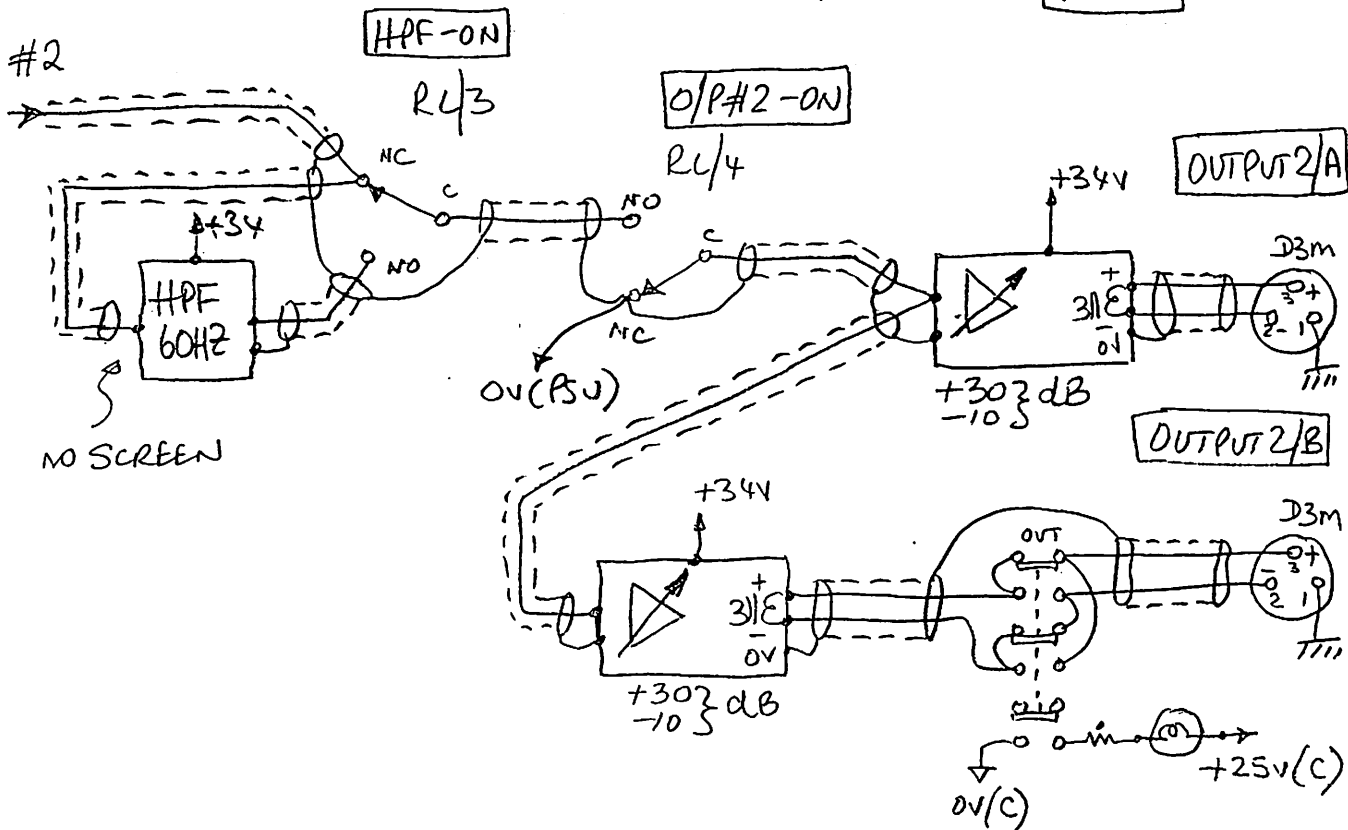

ALL GAIN POTS - 10K LINEAR.

From
O/P MIX'S

#3

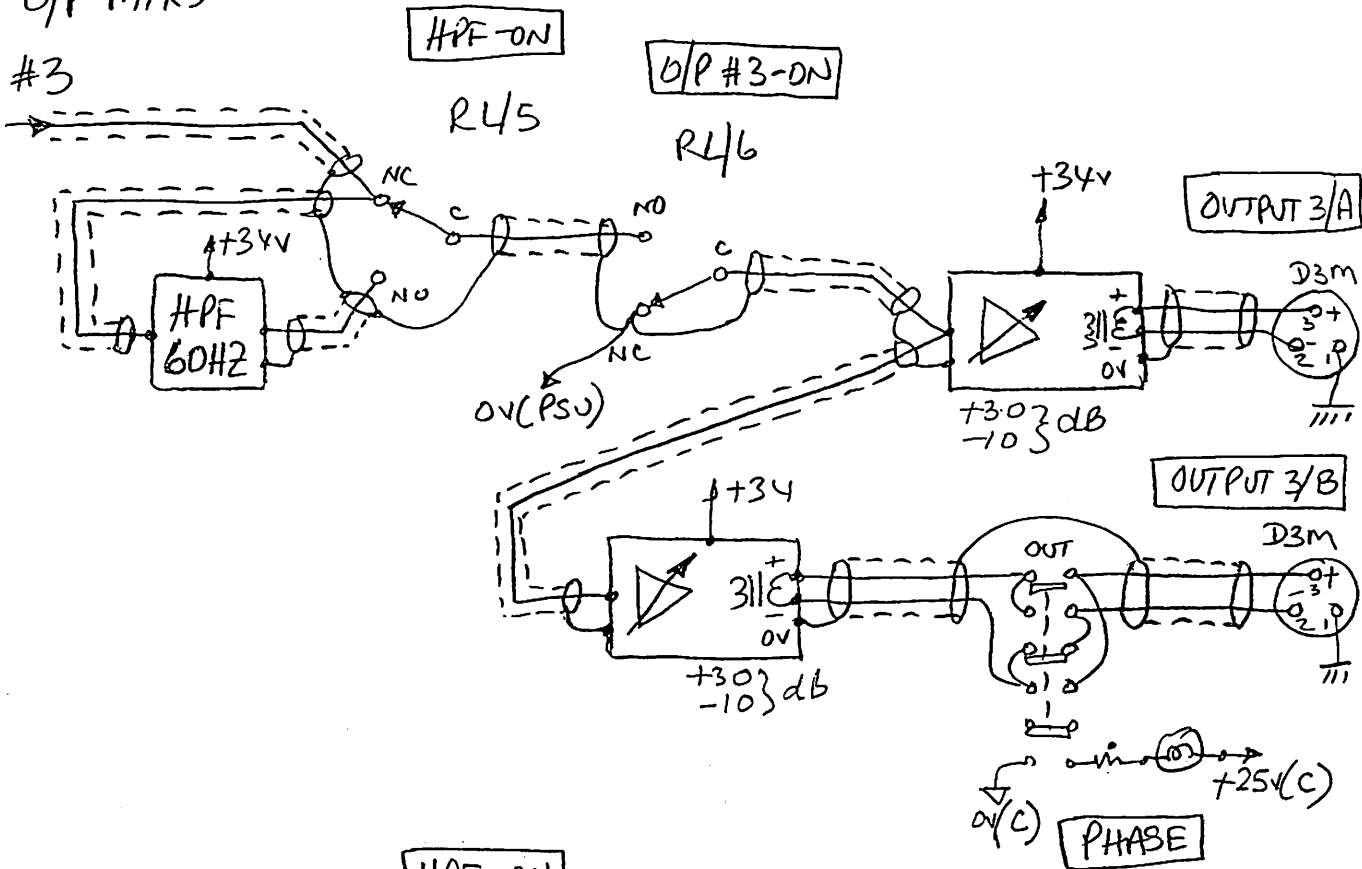

#4

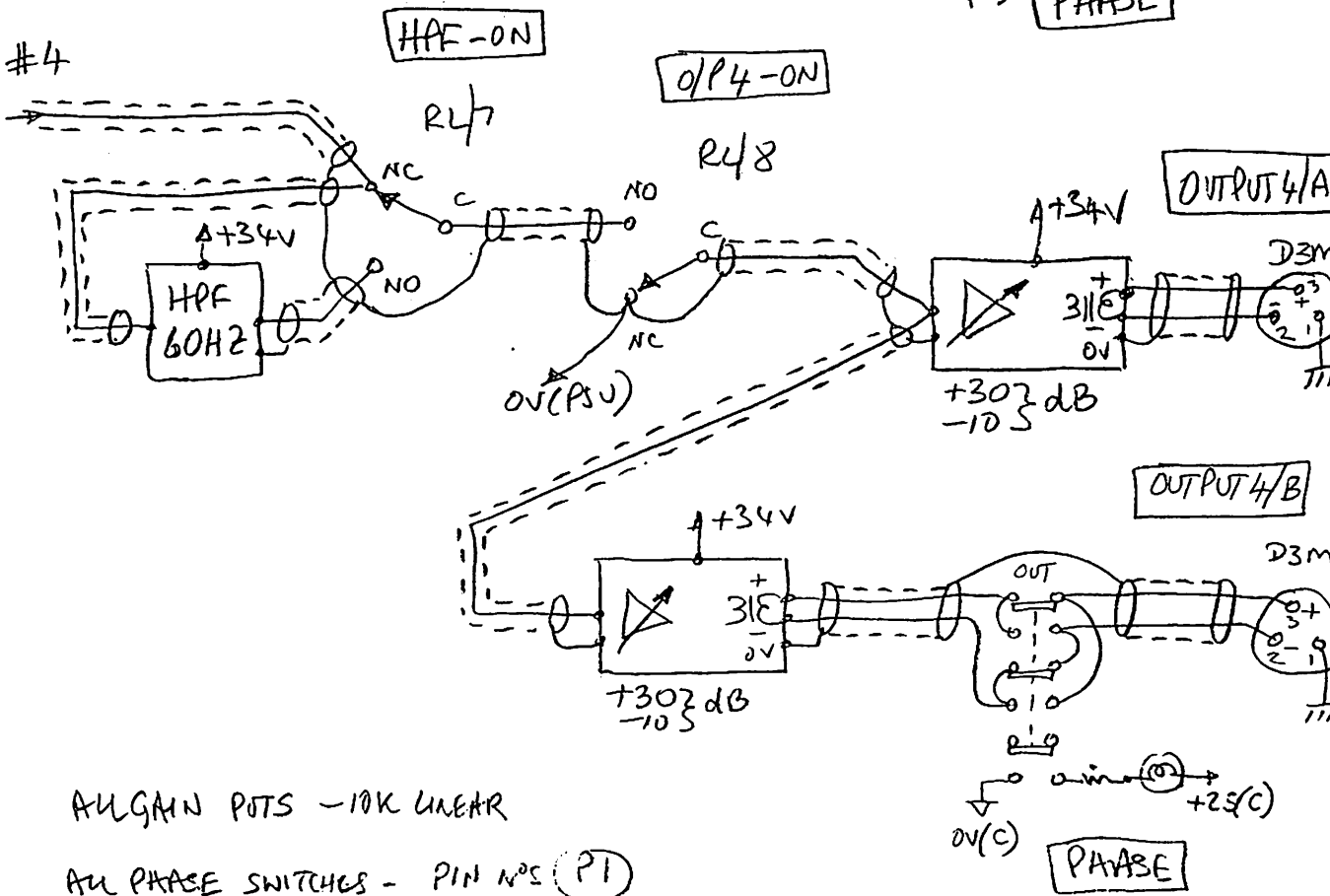

ALL GAIN POTS - 10K LINEAR

ALL PHASE SWITCHES - PIN NOS (P1)

POWER SUPPLIES

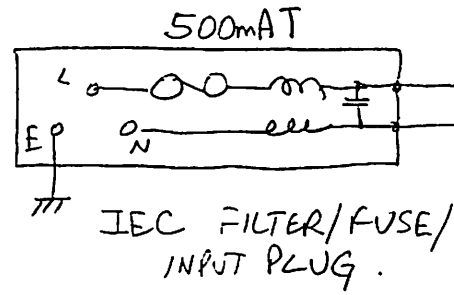

POWER

MT1-50VA MT2-20VA

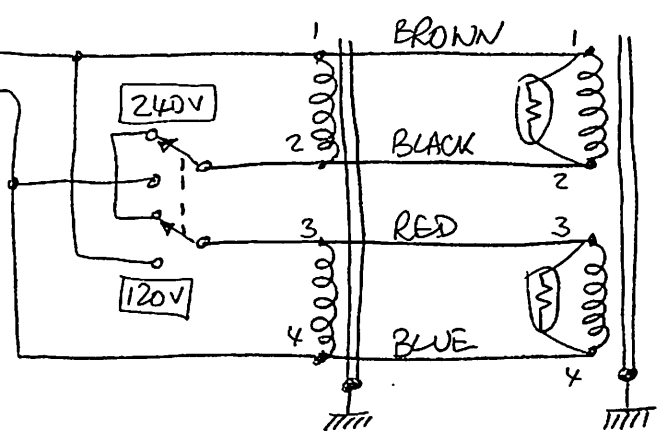

MT1-50VA

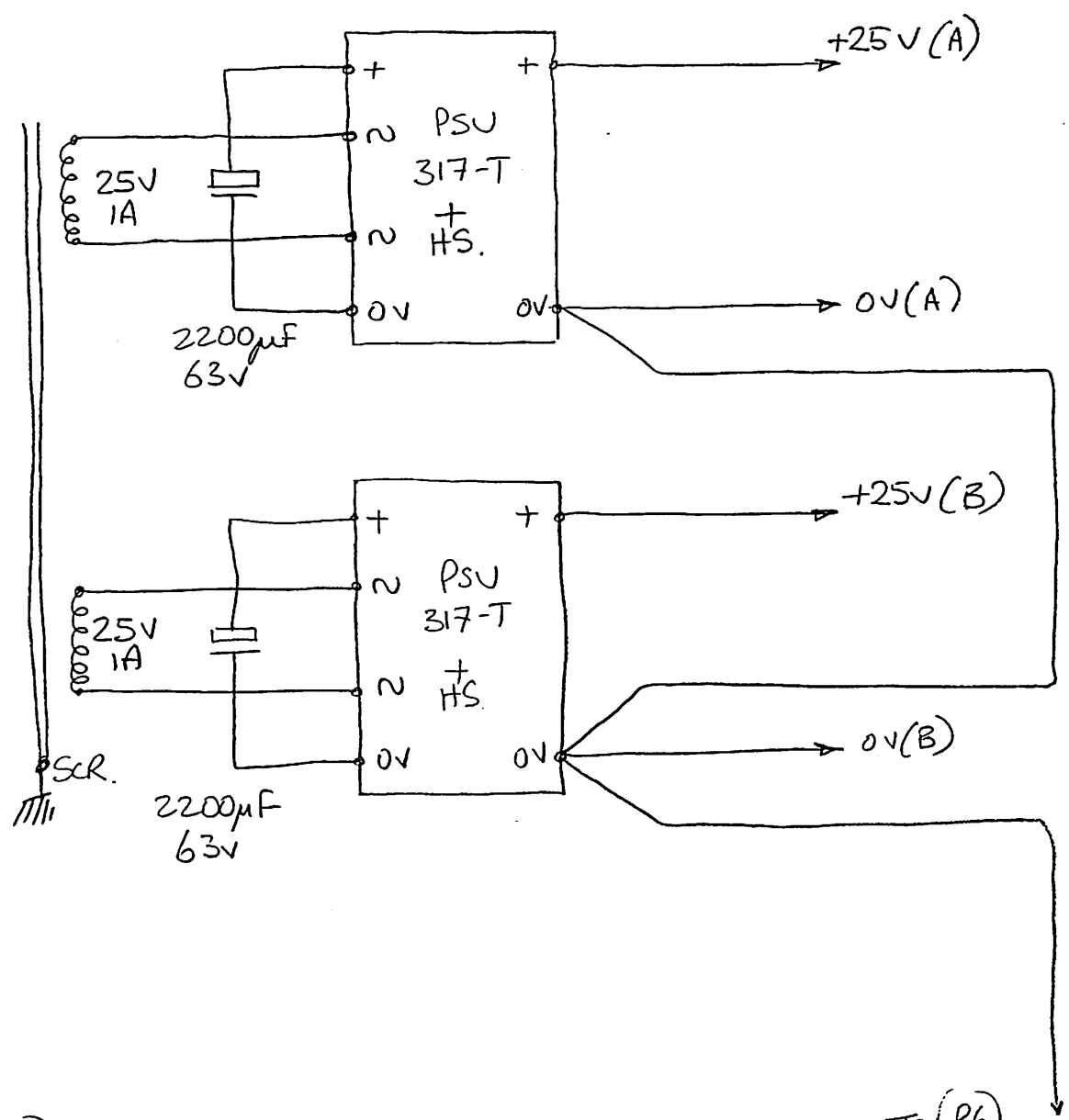

POWER SUPPLIES (CONT)

MT2 - 20VA

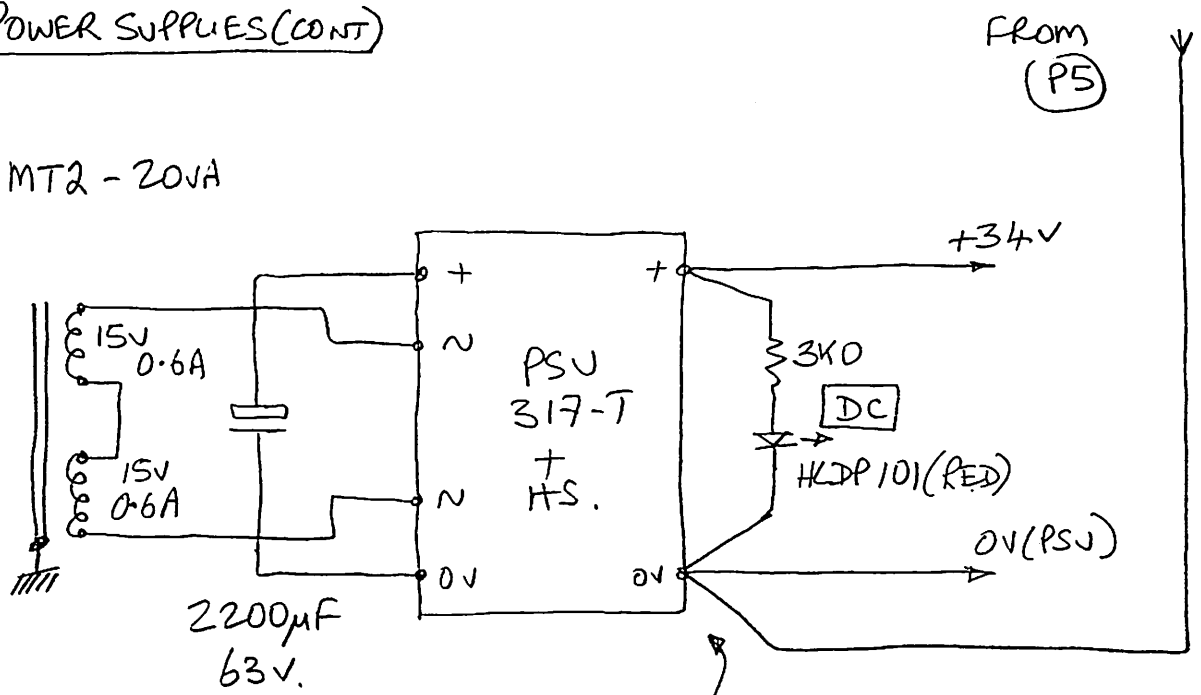

NB: GROUND AT I/P #1 ONLY!

ALL RELAYS:

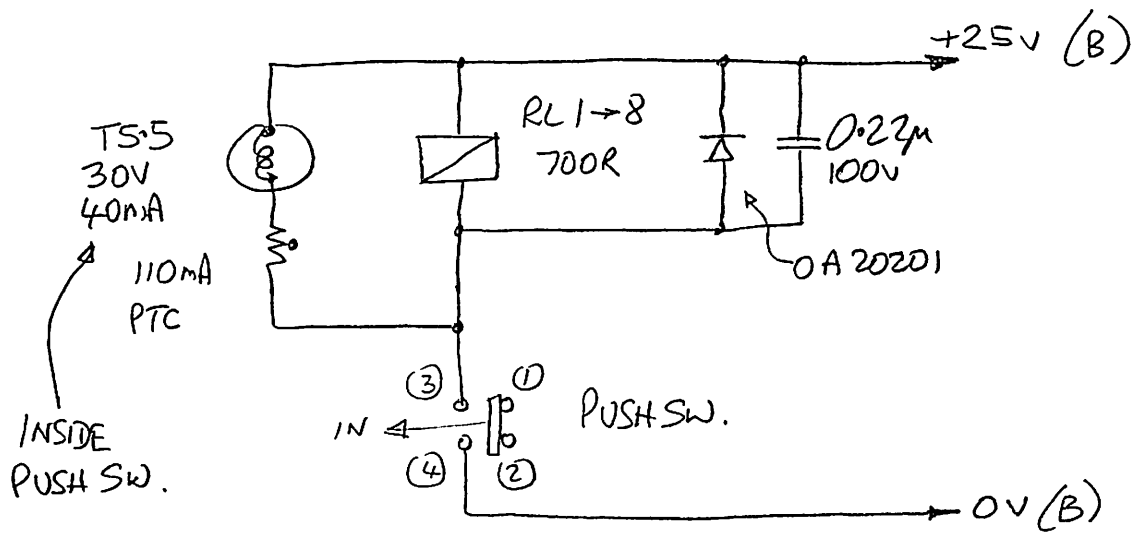

+25V DISTRIBUTION:

- +25V(A) — INPUT PHASE SWITCHES (4 OFF) } ≈ 700 mA
- INPUT ASSIGNMENT SWITCHES (16 OFF) }
- +25V(B) — RELAY 1 → 8 (CH. MUTES + HPFS) (8 OFF) } ≈ 700 mA
- OUTPUT PHASE SWITCHES (4 OFF) }

CONNECTING LEADS

1) INPUT #1 - 4 (FROM UNIT #1 OR #2 OR OTHER BALANCED SOURCE)

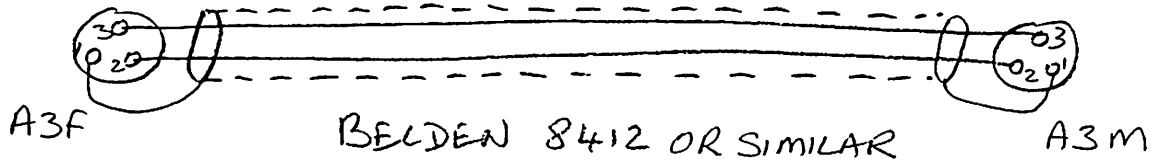

2) OUTPUTS TO AMPS (VIA TIE LINES OR DIRECT)

