

Service Manual

# DN780

Stereo Digital Reverb/Processor



**Audio engineering  
like no other  
in the world**

\*\*\* DN780 SERVICE MANUAL \*\*\*

13.AUG.85

GENERAL SYSTEM OVERVIEW

The DN780 Reverberator/Processor is split up into six circuit boards as follows:-

1. Power Supply Board
2. Front Panel/Display Board
3. Microprocessor Board
4. D.S.P. (Digital Signal Processor) Board
5. Converter Board
6. Audio In/Out Board

The circuit block diagram shows the interconnection between these boards.

1 POWER SUPPLY BOARD

This section converts the A.C mains voltage to the required D.C voltages. It contains all the mains voltage switches, mains transformer, secondary (low voltage) fuses, rectifiers and regulators to supply all the other boards (and the remote unit) with stabilized D.C Power.

2 FRONT PANEL/DISPLAY BOARD

This board contains the audio level control and headroom indicator, and the primary user interface which consists of the function keys, the display and display drivers. These are controlled by the microprocessor board.

3 MICROPROCESSOR BOARD

This is the primary control for the DN780. It decodes and displays information via Front Panel Board. It contains the remote interface circuitry. It stores all the user programs in its non-volatile memory and it has direct control over the D.S.P Board.

4. D.S.P. BOARD

This is a very high speed digital signal processor which is dedicated to perform all the computation required for Reverberation and other audio signal processing algorithms. The board contains a V.L.S.I. multiplier/accumulator which performs all the mathematical functions in double precision (32bit). It also contains the bulk storage memory (64k\*16), high speed scratch pad (1k\*16) memory and a high speed microcode controller which is under the direct control of the microprocessor. The board receives the converted audio signal (16bit linear) and sends the computed results to the convertor board.

5. CONVERTOR BOARD

This board converts the audio signal into a 16bit linear (2's complement) code which it sends to the D.S.P. Board. It also receives both processed output digital codes from the D.S.P. Board and converts them into analogue audio outputs. The input and output anti-aliasing filters on this board are proprietary thick film hybrids, which ensure long term stability and performance.

6. AUDIO IN/OUT BOARD

This board contains the differential input amplifier (transformer balanced is optional) which is both current and voltage balanced, also the output amplifiers and output transformers which are fitted as standard.

The most efficient method of servicing the DN780, due to the complexity of the circuit is on a circuit board exchange basis. A service kit is available, which includes the major circuit boards, plus test links/plugs to facilitate fault finding. The following fault chart, used in conjunction with the circuit diagrams and diagnostic routines should enable most faults to be easily located and cured.

The following test equipment is essential before commencing.

- 1..AC/DC multimeter or D.V.M.
- 2..Oscilloscope (20MHz minimum bandwidth).
- 3..Oscillator 1kHz.
- 4..High impedance Audio levelmeter.

Note 1: The Micro Board and the Convertor Board require extensive test equipment to repair faults, and absolutely no repairs or replacements should be attempted on the D.S.P Board apart from the replacement of IC's 47,48,53 and 54 (explained in the service fault finding list).

Note 2: 0dBu = 0.775 Vrms

## CONTENTS

### Fault Finding

- 1.No Audio & No Display
- 2.No Display & Audio works
- 3.No Audio & Display works
- 4.Distorted, Noisy, Intermittent Audio
- 5.ERR 1
- 6.ERR 2
- 7.ERR 3
- 8.Memory loss/bAt Lo
- 9.Display incorrect
- 10.Headroom Indicator
- 11.Faulty Remote
- 12.Intermittent Operation

### Alignment

- 13.Level setting guide
- 14.CMRR adjustment
- 15.Noise level adjustment
- 16.Grounding conditions
- 17.Diagnostic routines

NOTE: Before commencing any fault finding check that all internal cable connectors are firmly located and that all 'plug-in' integrated circuits are firmly in their sockets.

## FAULT FINDING

### 1.00 NO DISPLAY, NO AUDIO

Most likely cause a) Power supply failure  
b) D.C Voltages incorrect  
c) Faulty Microprocessor Board

### CHECK PROCEDURE

- 1.01 Is the fan running ? (if YES goto 1.04)
- 1.02 Check mains fuse and mains supply (Note:Mains fuse and spare are located in the mains inlet socket, the outer most fuse is the spare).
- 1.03 Check voltage selector switches (internal).
- 1.04 Check following D.C voltages on Power Supply Board (P.S.B.)  
+5v....4.8v - 5.2v  
+7v....6.5v - 7.5v  
+15v...14.8v - 15.2v  
-15v...14.8v - 15.2v  
If these are incorrect goto 1.06
- 1.05 If they are all correct, check D.C voltages on all circuit boards. If these are all correct replace the Microprocessor board.  
Note: If all D.C voltages are correct and the fan is still not running, then the fan is faulty. This will cause overheating of the power supply.
- 1.06 Remove all internal power cables ST1,ST2,ST3,ST4 from Power Supply Board (P.S.B) and re-check the D.C voltages as in 1.04. If these are correct goto 1.08.
- 1.07 Replace relevant fuse(s) if necessary.  
If the D.C voltages are still incorrect the fault lies on the Power Supply Board, likely faults are Regulators,Diode bridge,diodes,Transformer.
- 1.08 Disconnect the remote. Disconnect the Micro Board to Converter Board cable.(CB1)
- 1.09 Replace cable to ST3. Check +5v supply on P.S.B  
If this is not correct the fault lies on the Micro Board.
- 1.10 Replace cable to ST1 on P.S.B. Check +5v and +7v supplies on P.S.B. If these are not correct fault lies on Front Display Board.
- 1.11 Replace Remote cable. Check +5v supply on P.S.B. If this is not correct the fault lies in the Remote unit.

- 1.12 Replace cable to ST2 on P.S.B. Check +5v supply on P.S.B. If this is incorrect then the fault lies on the D.S.P Board.
- 1.13 The unit should now be displaying a normal Program.
- 1.14 Replace the Micro Board to Converter Board cable (CB1). Check the +5v supply. If this is incorrect the fault lies on the Converter Board.
- 1.15 Reconnect cable to ST4 on P.S.B. If the unit fails the fault lies on the Converter Board.

2.00 NO DISPLAY AND AUDIO OK.

Most likely cause

- a) Incorrect power on Display Board
- b) Faulty Microprocessor Board
- c) Faulty Display Board

CHECK PROCEDURE

- 2.01 Check +5v and +7v supplies to Front Display Board. If these are correct go to 2.03
- 2.02 Remove cable to ST1 on Power Supply Board. Check +5v and +7v supplies on P.S.B. If these are correct the fault lies on the Front Display Board, otherwise the fault lies on the Power Supply Board.
- 2.03 Check Micro Board to Front Display Board ribbon cable (CB2). If this appears OK, try selecting another program i.e. 31 'DELAY LINE'. If this does not appear to load correctly, the fault most likely lies on the Micro Board, otherwise try the Front Display Board.

3.00 NO AUDIO AND DISPLAY OK.

Most likely cause

- a) Incorrect power to Audio Section
- b) Faulty component on audio circuitry
- c) Faulty Converter Board
- d) Faulty Display Board

CHECK PROCEDURE

- 3.01 Inject a 1kHz sinewave at normal operating level.
- 3.02 Check +15v and -15v supplies on Power Supply Board. If these correct goto 3.06.
- 3.03 Remove Audio In/Out Board to Converter Board cable at ST6 on Audio I/O Board. Check +15v and -15v supplies. If these are correct the fault lies on the Converter Board.

- 3.04 Remove Audio In/Out Board to Front Board Cable at ST5 on Audio I/O Board. Check +15v and -15v supplies. If these are correct the fault lies on the Front Display Board.
- 3.05 Remove cable to ST4 on Power Supply Board. Check +15v and -15v supplies on P.S.B. If these are correct the fault lies on the Audio In/Out Board, otherwise the fault is in the Power supply section.
- 3.06 Is the Headroom indicator working?. If yes goto 3.08
- 3.07 Trace signal from input socket on Audio In/Out Board through to Headroom Indicator section on Front Display Board.
- 3.08 Trace signal from 'LEVEL CONTROL'. P1 on Front Display Board through to Pin1 SKT2 on Converter Board.
- 3.09 Check signal at pins 3 and 8 on ST2 on Converter Board.(use program 31 'DELAY LINE'). If these are correct the fault lies on the Audio In/Out Board.
- 3.10 Remove Converter Board to D.S.P Board ribbon cable (CB3). Reconfigure ST4 links on Converter Board to 'Test' position (see figure 1). If a spare link is not available use link at ST8 on Micro Board. If the signal now appears on the outputs the fault lies on the D.S.P Board, otherwise the fault is on the Converter Board.  
 Note: Before attempting to use the unit normally the link at ST8 on the Micro Board must be replaced and ST4 on the Converter Board should be linked in the 'Normal' position.

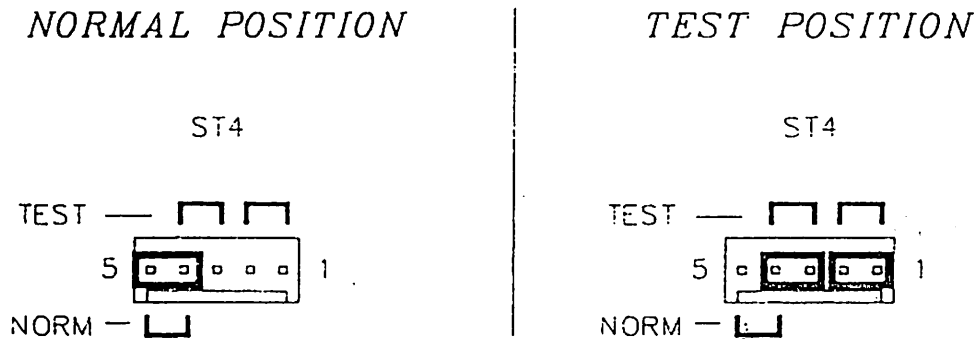

figure 1

4.00 **DISTORTED, NOISY, INTERMITTENT AUDIO**

Most likely cause a) Faulty D.S.P Board  
b) Faulty Converter Board  
c) Faulty component on audio circuitry

CHECK PROCEDURE

- 4.01 Is the signal OK when using Program 31 'DELAY LINE'. If yes the fault lies on the D.S.P Board. Replace it.
- 4.02 Remove Converter Board to D.S.P Board ribbon cable (CB3). Reconfigure ST4 links on Converter Board to 'Test' position (see figure 1). If a spare link is not available use link at ST8 on Micro Board. If the signal is now OK the fault lies on the D.S.P Board.
- 4.03 Remove cable on ST6 of Audio In/Out Board. Use 'Test Link Plug 1' on ST6 or connect pins 1,3 and 8 together. If the signal is now OK the fault lies on the Converter Board.
- 4.04 Remove cable on ST5 of Audio In/Out Board. Connect pins 1 and 2 on ST5 together. If the signal is now OK the fault lies in the audio section of the Front Display Board, otherwise the fault lies on the Audio In/Out Board.  
Note: Before attempting to use the unit normally, the link at ST8 on the Micro Board must be replaced and ST4 on the Converter Board should be linked in the 'Normal' position.
- 5.00 **ERROR 1**
- 5.01 When the unit is first powered-up it attempts to check every location in its program memory IC22 EPROM. If it fails, it will attempt to display Err 1. The causes of error 1 are:  
a)..The mains supply is insufficient.  
b)..One or more of the processor's address lines are being corrupted.  
c)..One or more of the processor's data lines are being corrupted.  
d)..The EPROM IC22 is faulty.
- 5.02 Confirm that the mains supply is stable and within the limits of the voltage setting.
- 5.03 Remove both Micro Board to D.S.P Board ribbon cables (CB4,CB5). Restart unit, if error 1 is still displayed, then fault lies on Micro Board. If error 2 then fault lies on D.S.P Board.



6.00 ERROR 2

6.01 After the unit confirms it can read its program memory correctly' it then writes a standard reverberation program to the D.S.P Board IC's 47,48 and then verifies that they are correct, if not a Err 2 is displayed.

The causes of Err 2 are:

- a)..Either IC47 or IC48 are faulty.
- b)..There is a fault in one of the Micro to D.S.P Board cables (CB4,CB5).
- c)..There is a major fault on the D.S.P Board.

6.02 Press [+] key. If Err 3 is displayed, fault lies on the D.S.P Board,Ribbon cables (CB4,CB5), or on power cable to the D.S.P Board.

6.03 If a program appears to load then the fault is most likely on the D.S.P Board and probably located in IC's 47,48. This can be confirmed by swapping IC 47 with 53 and IC 48 with 54 \*(Use extreme care, these IC's are static sensitive!)\*. If on restart the unit stops at Err 3 the faulty IC's are now located at 53,54. Replace IC's or Replace D.S.P Board.

7.00 ERROR 3

7.01 After the unit confirms it has written a program to the D.S.P Board it then writes a standard set of coefficients to the D.S.P Board IC's 53,54 and then verifies that they are correct, if not a Err 3 is displayed.

The causes of Err 3 are:

- a)..Either IC53 or IC54 are faulty.
- b)..There is a major fault on the D.S.P Board.

7.02 The fault is most likely on the D.S.P Board and probably located in IC's 53,54. This can be confirmed by swapping IC 47 with 53 and IC 48 with 54 \*(Use extreme care, these IC's are static sensitive!)\*. If on restart the unit stops at Err 2 the faulty IC's are now located at 47,48 replace IC's or replace D.S.P Board.

If Err 3 still appears replace D.S.P Board.

## 8.00 BAT LO and or MEMORY LOSS

- 8.01 After the unit has confirmed that it can read and write to the D.S.P Board, it reads a check-byte in the CMOS memory IC21 on the Micro Board, If this is correct the unit will load the last used program and continue to function normally. If the check-byte is incorrect the unit assumes that the CMOS memory has been corrupted, it then displays 'bAt Lo',clears all user memories, resets all status's to their default conditions, re-writes the check-byte, and loads program 01. Note: it is possible to simulate this condition by holding down both the [+],[-] keys during power-on.
- 8.02 Run diagnostic option 09, this will completely check the operation of the CMOS memory. If an error is displayed the fault lies in IC21 or on the Micro Board itself.
- 8.03 If it passes the above test, switch unit off and measure voltage across battery, if less than 2.5v replace it, otherwise the fault lies on the Micro-Board.  
Note: other possible causes are noisy mains supply and bad mains earth connection.

## 9.00 DISPLAY INCORRECT

- 9.01 Run diagnostic option 01, Check all display segments are on before pressing [-] key. If all segments appear OK the fault probably lies in the CMOS memory, IC 21 on Micro Board.
- 9.02 To flush the CMOS memory, switch unit off and while holding down both [+],[-] keys switch unit on, when the unit displays 'bAt Lo' release both keys.  
\*Note: flushing the CMOS memory erases all user memories and resets all status to their default conditions.
- 9.03 If the display is still incorrect replace Micro Board. If on replacing the Micro Board the unit is still not correct replace the Front Display Board.

10.00 **INCORRECT HEADROOM INDICATOR**

Most likely cause a) Faulty component on Front Display Board.

**CHECK PROCEDURE**

10.01 If the entire column is inoperative and the audio works the fault lies in the level meter section on the Front Display Board.

10.02 The 0dB LED (red) appears incorrect.

Note: this LED shows mathematical overload which can occur on some program settings when the peak signal level is lower than 0dB on the level meter.

The correct operation of the overload LED can be confirmed by running program 31 'DELAY LINE' with a 1kHz sinewave input signal. The overload LED should come on approximately 2.5 dB's below the output clipping point. At this point the O/L LED D1 on the D.S.P Board should also be on.

The reference level of the Level Meter can be adjusted by preset P2 on the Front Display Board. Use the level setting guide 13.00 to calibrate P2.

11.00 **FAULTY REMOTE**

11.01 By running the diagnostic routines the following operations of the Remote can be checked.

- Option 01..LED's operate
- 02..the keys are functioning
- 03..the sliders are working
- 04..the sliders are not noisy

11.02 If the unit fails any of the above tests, the fault most likely lies in the remote cable or box. If on replacement the fault still exists the fault lies on the Micro Board.

12.00 **INTERMITTENT OPERATION**

12.01 By using the diagnostic facilities most operations of the unit can be tested. If these appear OK. A check on the following should be done.

- a)..the unit is earthed by the mains cable.
- b)..all internal cables and boards are fully secure.
- c)..all IC's in sockets are firmly in place.
- d)..DC power rails are stable and within limits.
  - +5v.....4.8v - 5.2v
  - +7v.....6.5v - 7.5v
  - +15v.....14.8v - 15.2v
  - 15v.....14.8v - 15.2v

- e)..mains supply is clean,stable and within limits set by the voltage selector.
- f)..the fan is running.
- g)..unit has adequate ventilation. Maximum ambient temp 40C.

### 13.00 LEVEL SETTING GUIDE

Note: The 0v/chassis terminal located on the input XLR chassis fixing can be used for the ground (common) connection to the test equipment.

- 13.01 Select program 31 'DELAY LINE'
- 13.02 Set delay to zero.
- 13.03 Inject 1kHz sinewave @ +10dBu into INPUT socket.
- 13.04 Monitoring level at Pin 1 'SKT2 on Convertor Board adjust 'LEVEL CONTROL' for a level of +5.5dBu at Pin 1 SKT2.
- 13.05 Set preset P2 on Front Display Board so that the 3dB LED (yellow) on the 'Level Meter' just illuminates.
- 13.06 Adjust 'LEVEL CONTROL' for a level of +8dBu at Pin 1 SKT2 on Convertor Board.
- 13.07 Check level at Pin 3 or Pin 8 of SKT2 on Convertor Board and adjust preset P1 on Convertor Board for a level of +8dBu. The 0dB LED (red) and the O/L LED D1 on the D.S.P Board should both be on.
- 13.08 Setting Output Level's
- 13.09 The output level presets are accessible from the rear of the unit. With the conditions set as described in 13.01,02,03 and the 'LEVEL CONTROL' adjusted so that the 0dB LED (red) is just on, the signal level at the OUTPUT sockets will be apporoximately 2.5dB's below the internal clipping point of the unit.
- 13.10 This level is factory set at +8dBu and can be adjusted by the output level presets up to a maximum of +18dBu.

14.00 C.M.R.R SETTING (electronically input balanced units)

14.01 Set program 31 'DELAY LINE', delay at zero and the 'LEVEL POT' at approximately mid-position.

14.02 Join Pins 2 and 3 of the input XLR together and inject a 100Hz sine-wave across Pins 2 & 3 and Pin 1 (ground). See figure 2.

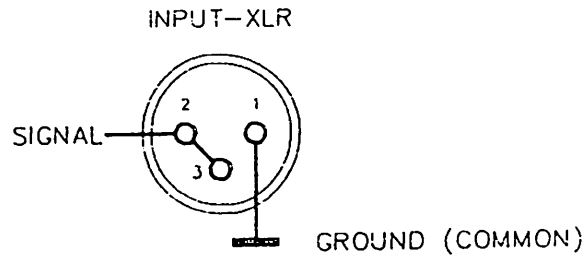

figure 2

14.03 While monitoring level at either Output Socket adjust preset P1 on Audio In/Out Board for minimum level.

15.00 NOISE LEVEL ADJUSTMENT

Note: This does not apply to Issue 1 & 2 Convertor Boards.

15.01 Set program 31 'DELAY LINE', delay at zero and remove input signal.

15.02 Monitor test point A on Convertor Board using an oscilloscope with time-base set to 20uS per div. Adjust preset P2 for a display like figure 3(b). This should be done with the D.S.P Board in its normal position.

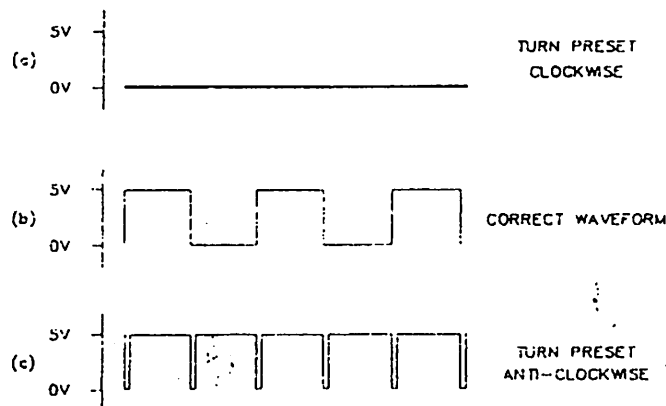

figure 3

15.03 Monitor noise level at output, preset P2 may be adjusted approx +/- 1/4 of a turn to achieve minimal noise level.

## 16.00 GROUNDING CONDITIONS

16.01 The chassis should ALWAYS be connected to the mains supply earth. It is hazardous to operate the unit without this connection.

16.02 Factory set units have audio grounds set as follows:

- a)..All XLR shells are connected to the chassis.
- b)..Pin 1 of all three XLR's are connected to the chassis via a blue wire link (L1) to the Audio I/O Board. This link may be removed.
- c)..Circuit ground (0v) is connected to the chassis via a green wire link (L2) to the Audio I/O Board. This link may be removed.

This allows any combination of signal grounding to be configured.

## 17.00 DIAGNOSTIC UTILITIES

### USING THE DIAGNOSTICS

- \* Press ([9]),([+][0]).
- \* The display will show [doS.    ] and the 'store' LED will flash.
- \* Enter 2 digit keys to select option.
- \* Pressing 00 will exit and restart the unit.

**CAUTION:** Beware of option 09 this will erase all user memories including protected ones !!. When this utility has been selected and the diagnostics are exit-ed the unit will display [bAt Lo    ] to show that the back-up memory has been corrupted.

### OPTIONS

- 00- Exit diagnostics and restart unit, memory 01 will load.
- 01- Display segments test. Press [-] for segment decay.
- 02- Button test. Pressing any button including remote, but excluding [IN] will cause the unit to display the key name plus a hex code. Press ([-][+]) to exit.
- 03- Remote slider test. Moving any slider will cause the unit to display it's relative HEX position and cause the associated 'track' LED and the 'remote' LED to flash. The HEX position display should range from 00 to FF. To exit press any button.

- 04- Remote slider noise test. With the remote sliders static the display will show the peak-noise. The number range is 0-9. Values less than 4 are satisfactory, values above 4 could cause a disturbance in the parameter settings if the 'REMOTE' is armed. To exit press any button.
- 05- Complete check of DSP memory IC's 53,54. Errors reported.
- 06- Complete check of DSP memory IC's 47,48. Errors reported.
- 07- DSPCOF memory status. To exit press ([+][-]).
- 08- Processor status display. Enter next option to continue.
- 09- Complete check of CMOS back-up memory (MICRO IC 21), takes a few seconds, status displayed. Errors reported.  
\*\*\*\*\* WARNING ALL USER MEMORIES ERASED \*\*\*\*\*
- 10,14 Not used.
- 15- Continuous R/W to DSP memory IC's 53,54. To exit press any button.
- 16- Continuous R/W to DSP memory IC's 47,48. To exit press any button.

## DN780 PARTS LIST

Printed on:09/09/85

DN780	D.S.P	BOARD				
REF	ITEM	VALUE	QTY	KTR:NO		
C3	CAPACITOR CERAMIC	47N	1	B2-2A047		
C6	CAP TANTALUM RADIAL	4.7/16V	1	B4-TB147		
C8	CAPACITOR CERAMIC	47N	1	B2-2A047		
C9	CAPACITOR CERAMIC	47N	1	B2-2A047		
C10	CAPACITOR CERAMIC	47N	1	B2-2A047		
C11	CAPACITOR CERAMIC	47N	1	B2-2A047		
C12	CAPACITOR CERAMIC	47N	1	B2-2A047		
C13	CAPACITOR CERAMIC	47N	1	B2-2A047		
C16	CAPACITOR CERAMIC	47N	1	B2-2A047		
C17	CAPACITOR CERAMIC	47N	1	B2-2A047		
C18	CAP TANTALUM RADIAL	22/16V	1	B4-TB222		
C19	CAPACITOR CERAMIC	47N	1	B2-2A047		
C20	CAPACITOR CERAMIC	47N	1	B2-2A047		
C21	CAPACITOR CERAMIC	47N	1	B2-2A047		
C22	CAPACITOR CERAMIC	47N	1	B2-2A047		
C23	CAPACITOR CERAMIC	47N	1	B2-2A047		
C32	CAPACITOR CERAMIC	47N	1	B2-2A047		
C33	CAPACITOR CERAMIC	47N	1	B2-2A047		
C36	CAP POLYSTRENE 2.5%	120PF	1	B3-10120		
C38	CAPACITOR CERAMIC	47N	1	B2-2A047		
C39	CAP TANTALUM RADIAL	2.2/16V	1	B4-TB122		
C40	CAP TANTALUM RADIAL	2.2/16V	1	B4-TB122		
C41	CAP TANTALUM RADIAL	2.2/16V	1	B4-TB122		
C42	CAP TANTALUM RADIAL	2.2/16V	1	B4-TB122		
C43	CAP TANTALUM RADIAL	2.2/16V	1	B4-TB122		
C44	CAP TANTALUM RADIAL	2.2/16V	1	B4-TB122		
C45	CAP TANTALUM RADIAL	2.2/16V	1	B4-TB122		
C46	CAP TANTALUM RADIAL	2.2/16V	1	B4-TB122		
C47	CAPACITOR CERAMIC	47N	1	B2-2A047		
C48	CAPACITOR CERAMIC	47N	1	B2-2A047		
C49	CAPACITOR CERAMIC	47N	1	B2-2A047		
C50	CAPACITOR CERAMIC	47N	1	B2-2A047		
C51	CAPACITOR CERAMIC	47N	1	B2-2A047		
C52	CAPACITOR CERAMIC	47N	1	B2-2A047		
C53	CAPACITOR CERAMIC	47N	1	B2-2A047		
C54	CAPACITOR CERAMIC	47N	1	B2-2A047		
C56	CAPACITOR CERAMIC	47N	1	B2-2A047		
C57	CAPACITOR CERAMIC	15P	1	B2-10015		
C58	CAP POLYSTYRENE 2.5%	220PF	1	B3-10220		
C59	CAPACITOR CERAMIC	47P	1	B2-10047		
C60	CAP POLYSTYRENE 2.5%	100PF	1	B3-10100		
D1	RED LED 3mm ROUND	GL-3AR2	1	D1-AL209		
D2	DIODE	1N4148	1	D1-A4148		
D3	RED LED 3mm ROUND	GL-3AR2	1	D1-AL209		
IC1	1K * 4 SRAM	2148	1	D5-F2148		
IC1S	18 PIN DIL SOCKET	18 PIN DIL SOCKET	1	E2-ES181		
IC2	1K * 4 SRAM	2148	1	D5-F2148		
IC2S	18 PIN DIL SOCKET	18 PIN DIL SOCKET	1	E2-ES181		
IC3	1K * 4 SRAM	2148	1	D5-F2148		
IC3S	18 PIN DIL SOCKET	18 PIN DIL SOCKET	1	E2-ES181		
IC4	1K * 4 SRAM	2148	1	D5-F2148		



DN780 D.S.P BOARD

REF	ITEM	VALUE	QTY	KTR:NO-
IC4S	18 PIN DIL SOCKET	18 PIN DIL SOCKET	1	E2-ES181
IC5	TTL IC FAST	74F257	1	D3-7F257
IC6	TTL IC FAST	74F257	1	D3-7F257
IC7	TTL IC FAST	74F257	1	D3-7F257
IC8	TTL IC FAST	74F257	1	D3-7F257
IC9	TTL IC LS	74LS86	1	D3-7A086
IC10	TTL IC LS	74LS122	1	D3-7A122
IC11	16 BIT MULTIPLIER	1010JD	1	D5-X1010
IC11S	64PIN IC SOCKET	64PIN IC SOCKET	1	E2-ES641
IC12	64K DRAM IC 150ns	4564-150ns	1	D5-F64K1
IC12S	16 PIN DIL SOCKET	16 PIN DIL SOCKET	1	E2-ES161
IC13	64K DRAM IC 150ns	4564-150ns	1	D5-F64K1
IC13S	16 PIN DIL SOCKET	16 PIN DIL SOCKET	1	E2-ES161
IC14	64K DRAM IC 150ns	4564-150ns	1	D5-F64K1
IC14S	16 PIN DIL SOCKET	16 PIN DIL SOCKET	1	E2-ES161
IC15	64K DRAM IC 150ns	4564-150ns	1	D5-F64K1
IC15S	16 PIN DIL SOCKET	16 PIN DIL SOCKET	1	E2-ES161
IC16	64K DRAM IC 150ns	4564-150ns	1	D5-F64K1
IC16S	16 PIN DIL SOCKET	16 PIN DIL SOCKET	1	E2-ES161
IC17	64K DRAM IC 150ns	4564-150ns	1	D5-F64K1
IC17S	16 PIN DIL SOCKET	16 PIN DIL SOCKET	1	E2-ES161
IC18	64K DRAM IC 150ns	4564-150ns	1	D5-F64K1
IC18S	16 PIN DIL SOCKET	16 PIN DIL SOCKET	1	E2-ES161
IC19	64K DRAM IC 150ns	4564-150ns	1	D5-F64K1
IC19S	16 PIN DIL SOCKET	16 PIN DIL SOCKET	1	E2-ES161
IC20	64K DRAM IC 150ns	4564-150ns	1	D5-F64K1
IC20S	16 PIN DIL SOCKET	16 PIN DIL SOCKET	1	E2-ES161
IC21	64K DRAM IC 150ns	4564-150ns	1	D5-F64K1
IC21S	16 PIN DIL SOCKET	16 PIN DIL SOCKET	1	E2-ES161
IC22	64K DRAM IC 150ns	4564-150ns	1	D5-F64K1
IC22S	16 PIN DIL SOCKET	16 PIN DIL SOCKET	1	E2-ES161
IC23	64K DRAM IC 150ns	4564-150ns	1	D5-F64K1
IC23S	16 PIN DIL SOCKET	16 PIN DIL SOCKET	1	E2-ES161
IC24	64K DRAM IC 150ns	4564-150ns	1	D5-F64K1
IC24S	16 PIN DIL SOCKET	16 PIN DIL SOCKET	1	E2-ES161
IC25	64K DRAM IC 150ns	4564-150ns	1	D5-F64K1
IC25S	16 PIN DIL SOCKET	16 PIN DIL SOCKET	1	E2-ES161
IC26	64K DRAM IC 150ns	4564-150ns	1	D5-F64K1
IC26S	16 PIN DIL SOCKET	16 PIN DIL SOCKET	1	E2-ES161
IC27	64K DRAM IC 150ns	4564-150ns	1	D5-F64K1
IC27S	16 PIN DIL SOCKET	16 PIN DIL SOCKET	1	E2-ES161
IC28	TTL IC FAST	74F08	1	D3-7F008
IC29	TTL IC LS	74LS158	1	D3-7A158
IC30	TTL IC LS	74LS158	1	D3-7A158
IC31	TTL IC LS	74LS283	1	D3-7A283
IC32	TTL IC LS	74LS283	1	D3-7A283
IC33	TTL IC LS	74LS283	1	D3-7A283
IC34	TTL IC LS	74LS283	1	D3-7A283
IC35	TTL IC LS	74LS374	1	D3-7A374
IC36	TTL IC LS	74LS393	1	D3-7A393
IC37	TTL IC LS	74LS374	1	D3-7A374
IC38	TTL IC LS	74LS393	1	D3-7A393
IC39	TTL IC LS	74LS74	1	D3-7A074

DN780 D.S.P BOARD

REF	ITEM	VALUE	QTY	KTR:NO
IC40	TTL IC LS	74LS00	1	D3-7A000
IC41	TTL IC LS	74LS374	1	D3-7A374
IC42	TTL IC LS	74LS374	1	D3-7A374
IC43	TTL IC LS	74LS174	1	D3-7A174
IC44	32 X 8 PROM IC	7603	1	D5-P7603
IC44S	16 PIN DIL SOCKET	16 PIN DIL SOCKET	1	E2-ES161
IC45	TTL IC LS	74LS374	1	D3-7A374
IC46	TTL IC LS	74LS374	1	D3-7A374
IC47	1K * 4 SRAM	2148	1	D5-F2148
IC47S	18 PIN DIL SOCKET	18 PIN DIL SOCKET	1	E2-ES181
IC48	1K * 4 SRAM	2148	1	D5-F2148
IC48S	18 PIN DIL SOCKET	18 PIN DIL SOCKET	1	E2-ES181
IC49	TTL IC LS	74LS245	1	D3-7A245
IC50	TTL IC LS	74LS163A	1	D3-7A163
IC51	TTL IC LS	74LS163A	1	D3-7A163
IC52	TTL IC LS	74LS163A	1	D3-7A163
IC53	1K * 4 SRAM	2148	1	D5-F2148
IC53S	18 PIN DIL SOCKET	18 PIN DIL SOCKET	1	E2-ES181
IC54	1K * 4 SRAM	2148	1	D5-F2148
IC54S	18 PIN DIL SOCKET	18 PIN DIL SOCKET	1	E2-ES181
IC55	TTL IC LS	74LS245	1	D3-7A245
IC56	TTL IC LS	74LS367	1	D3-7A367
IC57	TTL IC LS	74LS367	1	D3-7A367
IC58	TTL IC LS	74LS02	1	D3-7A002
IC59	TTL IC FAST	74F04	1	D3-7F004
IC60	TTL IC LS	74LS74	1	D3-7A074
IC61	TTL IC LS	74LS27	1	D3-7A027
IC62	TTL IC LS	74LS08	1	D3-7A008
IC63	TTL IC LS	74LS04	1	D3-7A004
IC64	TTL IC LS	74LS32	1	D3-7A032
IC65	TTL IC LS	74LS74	1	D3-7A074
IC66	TTL IC LS	74LS04	1	D3-7A004
PC1	PCB 2638	DN780 DSP BRD	1	E6-02638
R1	5% RESISTOR	2K2	1	A1-12200
R3	5% RESISTOR	1K	1	A1-11000
R4	5% RESISTOR	22K	1	A1-30022
R5	5% RESISTOR	5K6	1	A1-15600
R6	5% RESISTOR	680R	1	A1-10680
R7	5% RESISTOR	1K	1	A1-11000
R8	5% RESISTOR	680R	1	A1-10680
R9	5% RESISTOR	1K	1	A1-11000
R10	5% RESISTOR	220R	1	A1-10220
R11	5% RESISTOR	2K2	1	A1-12200
R12	5% RESISTOR	1K5	1	A1-11500
R13	5% RESISTOR	220R	1	A1-10220
R14	5% RESISTOR	150R	1	A1-10150
R15	5% RESISTOR	2K2	1	A1-12200
R16	5% RESISTOR	100R	1	A1-10100
RP3	8 COMMON RESISTO PAK	8 COMMON 1K5	1	A3-C8215
RP4	4 ISOLATED RESIS PAK	4 ISOLATED 47R	1	A3-C4047
RP5	4 ISOLATED RESIS PAK	4 ISOLATED 47R	1	A3-C4047
RP6	3 ISOLATED RESIS PAK	3 ISOLATED 47R	1	A3-C3047
ST1	20PIN RT IDC HEADER	20PIN RT IDC HEAD PC	1	E2-BP204

DN780 D.S.P BOARD

REF	ITEM	VALUE	QTY	KTR: NO
ST2	16 WAY PIN HEADER	16 WAY RIGHT HEADER	1	E2-CP163
ST3	16 WAY PIN HEADER	16 WAY RIGHT HEADER	1	E2-CP163
ST4	MOLEX 6PIN RT-ANGLE	0.156 * 6P RIGHT ANG	1	E2-BP063
X1	CRYSTAL 15MHZ	CRYSTAL 15MHZ	1	E5-A0003

DN780 MICRO-PROCESSOR BOARD

BT1	LITHIUM BATT DN780	LIM2016P1	1	E3-D0004
C1	CAPACITOR PLASTIC 5%	.15MFD	1	B1-20150
C2	CAPACITOR PLASTIC 5%	.15MFD	1	B1-20150
C3	CAPACITOR PLASTIC 5%	.15MFD	1	B1-20150
C4	CAPACITOR PLASTIC 5%	.15MFD	1	B1-20150
C5	CAPACITOR PLASTIC 5%	10N	1	B1-20010
C6	CAPACITOR PLASTIC 5%	33N 5%	1	B1-20033
C7	CAPACITOR CERAMIC	47N	1	B2-2A047
C9	CAP TANTALUM RADIAL	15/16V	1	B4-TB215
C10	CAPACITOR CERAMIC	47N	1	B2-2A047
C11	CAPACITOR CERAMIC	47N	1	B2-2A047
C13	CAPACITOR CERAMIC	47N	1	B2-2A047
C14	CAP TANTALUM RADIAL	22/16V	1	B4-TB222
C16	CAPACITOR CERAMIC	47N	1	B2-2A047
C17	CAPACITOR CERAMIC	47N	1	B2-2A047
C18	CAPACITOR CERAMIC	47N	1	B2-2A047
C19	CAPACITOR CERAMIC	47N	1	B2-2A047
C20	CAP TANTALUM RADIAL	2.2/16V	1	B4-TB122
C21	CAPACITOR CERAMIC	47N	1	B2-2A047
C23	CAPACITOR CERAMIC	47N	1	B2-2A047
C24	CAPACITOR CERAMIC	47N	1	B2-2A047
C25	CAPACITOR CERAMIC	47N	1	B2-2A047
C26	CAPACITOR CERAMIC	47P	1	B2-10047
D1	ZENNER DIODE	3V6 400mW	1	D1-A03V6
D2	REFERENCE DIODE	2.45V REF	1	D1-AZ404
D3	RED LED 3mm ROUND	GL-3AR2	1	D1-AL209
D4	DIODE	1N4148	1	D1-A4148
D5	DIODE	1N4148	1	D1-A4148
D6	ZENNER DIODE	3V6 400mW	1	D1-A03V6
IC1	TTL IC LS	74LS04	1	D3-7A004
IC2	CMOS IC	4016	1	D4-14016
IC2S	14 PIN DIL SOCKET	14 PIN DIL SOCKET	1	E2-ES141
IC3	A/D CONVERTOR IC	7002	1	D5-AD002
IC4	TTL IC LS	74LS245	1	D3-7A245
IC5	TTL IC LS	74LS74	1	D3-7A074
IC6	TTL IC FAST	74F04	1	D3-7F004
IC7	TTL IC LS	74LS377	1	D3-7A377
IC8	TTL IC LS	74LS373	1	D3-7A373
IC9	TTL IC LS	74LS04	1	D3-7A004
IC10	TTL IC LS	74LS10	1	D3-7A010
IC11	TTL IC LS	74LS138	1	D3-7A138
IC12	MICROPROCESSOR IC	Z80A	1	D5-Z80AM
IC13	SUPPLY MONT (RESET)	TL 7705	1	D3-T7705
IC14	TTL IC LS	74LS74	1	D3-7A074
IC15	TTL IC LS	74LS03	1	D3-7A003
IC16	DISPLAY/KEYBRD IC	8279	1	D5-M8279
IC17	TTL IC LS	74LS138	1	D3-7A138

DN780 MICRO-PROCESSOR BOARD

REF	ITEM	VALUE	QTY	KTR:NO-
IC18	TTL IC STD	7416	1	D3-70016
IC19	TTL IC STD	7416	1	D3-70016
IC20	CMOS IC	4016	1	D4-14016
IC20S	14 PIN DIL SOCKET	14 PIN DIL SOCKET	1	E2-ES141
IC21	2K X 8 CMOS SRAM	6117LP	1	D5-F6117
IC21S	24 PIN DIL SOCKET	24 PIN DIL SOCKET	1	E2-ES241
IC22	16K X 8 EPROM IC	27128	1	D5-T7128
IC22S	28PIN LOCK IC SOCKET	28PIN LOCK IC SOCKET	1	E2-ES282
PC1	PCB 2640	DN780 MICRO BRD	1	E6-02640
Q1	TRANSISTOR	BC184 OR EQUIV	1	D1-C184C
Q2	TRANSISTOR	BC184 OR EQUIV	1	D1-C184C
Q3	TRANSISTOR	BC184 OR EQUIV	1	D1-C184C
R1	5% RESISTOR	10K	1	A1-30010
R2	5% RESISTOR	10K	1	A1-30010
R3	5% RESISTOR	10K	1	A1-30010
R4	5% RESISTOR	10K	1	A1-30010
R5	5% RESISTOR	24K	1	A1-30024
R6	5% RESISTOR	24K	1	A1-30024
R7	5% RESISTOR	24K	1	A1-30024
R8	5% RESISTOR	24K	1	A1-30024
R9	5% RESISTOR	120R	1	A1-10120
R10	5% RESISTOR	390R	1	A1-10390
R11	5% RESISTOR	47K	1	A1-30047
R12	5% RESISTOR	47K	1	A1-30047
R13	5% RESISTOR	47K	1	A1-30047
R14	5% RESISTOR	47K	1	A1-30047
R15	5% RESISTOR	47K	1	A1-30047
R16	5% RESISTOR	10K	1	A1-30010
R17	5% RESISTOR	680R	1	A1-10680
R18	5% RESISTOR	1K	1	A1-11000
R19	5% RESISTOR	5K6	1	A1-15600
R20	5% RESISTOR	330R	1	A1-10330
R21	5% RESISTOR	10K	1	A1-30010
R22	5% RESISTOR	5K6	1	A1-15600
R23	5% RESISTOR	5K6	1	A1-15600
R24	5% RESISTOR	5K6	1	A1-15600
R25	5% RESISTOR	5K6	1	A1-15600
R26	5% RESISTOR	5K6	1	A1-15600
R27	5% RESISTOR	5K6	1	A1-15600
R28	5% RESISTOR	10K	1	A1-30010
R29	5% RESISTOR	10K	1	A1-30010
R30	5% RESISTOR	10K	1	A1-30010
R31	5% RESISTOR	5K6	1	A1-15600
R32	5% RESISTOR	10K	1	A1-30010
R33	5% RESISTOR	5K6	1	A1-15600
R34	5% RESISTOR	5K6	1	A1-15600
R35	5% RESISTOR	10K	1	A1-30010
R36	5% RESISTOR	10K	1	A1-30010
R37	5% RESISTOR	10K	1	A1-30010
R38	5% RESISTOR	5K6	1	A1-15600
R39	5% RESISTOR	5K6	1	A1-15600
R40	5% RESISTOR	5K6	1	A1-15600
R41	5% RESISTOR	1K	1	A1-11000

**DN780 MICRO-PROCESSOR BOARD**

REF	ITEM	VALUE	QTY	KTR: NO-
R42	5% RESISTOR	100R	1	A1-10100
R43	5% RESISTOR	3K3	1	A1-13300
R44	5% RESISTOR	1K	1	A1-11000
ST1	15WAY DEE SOC RT-PCB	15WAT DEE SOC RT-PCB	1	E2-BS152
ST2	MOLEX 6 PIN STRAIGHT	0.156 * 6PIN STRAIT	1	E2-BP064
ST3	MOLEX 8 PIN LATCHED	0.1 * 8PIN LATCHED	1	E2-BP082
ST4	16 WAY PIN HEADER	VERTICAL LOCK TYPE	1	E2-CP164
ST5	16 WAY PIN HEADER	VERTICAL LOCK TYPE	1	E2-CP164
ST6	MOLEX 34P SHROUDED	2X17PIN SHROUDED SET	1	E2-BP341
ST7	MOLEX 20P SHROUDED	2X10PIN SHROUDED SET	1	E2-BP203
ST8	MOLEX 2 PIN LATCHED	0.1 * 2PIN LATCHED	1	E2-BP021
ST8A	MOLEX 2 WAY PLUG	2W X 0.1 JUMP PLUG	1	E2-BS02A
ST9	MOLEX 3 PIN	0.1 3 PIN SET LATCH	1	E2-BP031
ST9A	MOLEX 2 WAY PLUG	2W X 0.1 JUMP PLUG	1	E2-BS02A
ST10	MOLEX 2 PIN LATCHED	0.1 * 2PIN LATCHED	1	E2-BP021
X1	CRYSTAL 4MHZ XTAL	4 MEG	1	E5-A0002
ZA1	SCREW	M3 X 10 P/HD C+P	2	F1-GB102
ZA2	PAIR DEE TYPE SCREWS	FEMALE	2	F1-Z0004
ZB1	SHAKEPROOF WASHER	M3 BZP	2	F1-DB032
ZC1	NUTS	M3 BZP	2	F1-AB002

**DN780 CONVERTOR BOARD**

C3	CAPACITOR CERAMIC	47N	1	B2-2A047
C5	CAPACITOR CERAMIC	47N	1	B2-2A047
C7	CAPACITOR CERAMIC	47N	1	B2-2A047
C8	CAPACITOR CERAMIC	47N	1	B2-2A047
C10	CAPACITOR CERAMIC	47N	1	B2-2A047
C11	CAP TANTALUM RADIAL	2.2/16V	1	B4-TB122
C12	CAPACITOR CERAMIC	47N	1	B2-2A047
C13	CAPACITOR CERAMIC	47N	1	B2-2A047
C14	CAP TANTALUM RADIAL	2.2/16V	1	B4-TB122
C17	CAP POLYSTYRENE 2.5%	560PF	1	B3-10560
C18	CAP TANTALUM RADIAL	2.2/16V	1	B4-TB122
C19	CAPACITOR CERAMIC	47N	1	B2-2A047
C20	CAP TANTALUM RADIAL	2.2/16V	1	B4-TB122
C21	CAPACITOR CERAMIC	47N	1	B2-2A047
C22	CAP TANTALUM RADIAL	2.2/16V	1	B4-TB122
C23	CAP POLYSTYRENE 2.5%	1N5	1	B3-11500
C26	CAP POLYSTYRENE 2.5%	1N5	1	B3-11500
C29	CAP POLYPROPYLENE	6N8 2.5%	1	B6-16800
C30	CAP POLYSTYRENE 2.5%	1N8	1	B3-11800
C31	CAP POLYPROPYLENE	6N8 2.5%	1	B6-16800
C32	CAP POLYSTYRENE 2.5%	1N8	1	B3-11800
C33	CAP POLYPROPYLENE	6N8 2.5%	1	B6-16800
C34	CAP POLYSTYRENE 2.5%	1N8	1	B3-11800
C35	CAP POLYPROPYLENE	6N8 2.5%	1	B6-16800
C36	CAP POLYSTYRENE 2.5%	1N8	1	B3-11800
C40	CAPACITOR PLASTIC 5%	2N2	1	B1-12200
C41	CAPACITOR PLASTIC 5%	2N2	1	B1-12200
C43	CAP POLYPROPYLENE	6N8 2.5%	1	B6-16800
C44	CAP POLYSTYRENE 2.5%	1N8	1	B3-11800
C45	CAP POLYPROPYLENE	6N8 2.5%	1	B6-16800
C46	CAP POLYSTYRENE 2.5%	1N8	1	B3-11800

DN780 CONVERTOR BOARD

REF	ITEM	VALUE	QTY	KTR: NO-
C49	CAPACITOR CERAMIC	47N	1	B2-2A047
C50	CAP TANTALUM RADIAL	2.2/16V	1	B4-TB122
C53	CAP TANTALUM RADIAL	22/16V	1	B4-TB222
C55	CAP TANTALUM RADIAL	15/16V	1	B4-TB215
D1	DIODE	1N4148	1	D1-A4148
D2	DIODE	1N4148	1	D1-A4148
D3	ZENNER DIODE	5V1 400mW	1	D1-A05V1
IC1	TTL IC LS	74LS373	1	D3-7A373
IC2	TTL IC LS	74LS373	1	D3-7A373
IC3	TTL IC LS	74LS374	1	D3-7A374
IC4	TTL IC LS	74LS374	1	D3-7A374
IC5	S.A.R 8BIT LS	25L03	1	D3-L2503
IC5S	16 PIN DIL SOCKET	16 PIN DIL SOCKET	1	E2-ES161
IC6	S.A.R 8BIT LS	25L03	1	D3-L2503
IC6S	16 PIN DIL SOCKET	16 PIN DIL SOCKET	1	E2-ES161
IC7	D/A CONVERTOR IC	PCM53I	1	D5-DA53I
IC7S	24 PIN DIL SOCKET	24 PIN DIL SOCKET	1	E2-ES241
IC8	D/A CONVERTOR IC	PCM 53V	1	D5-DA53V
IC8S	24 PIN DIL SOCKET	24 PIN DIL SOCKET	1	E2-ES241
IC9	TTL IC LS	74LS393	1	D3-7A393
IC10	32 X 8 PROM IC	7603	1	D5-P7603
IC10S	16 PIN DIL SOCKET	16 PIN DIL SOCKET	1	E2-ES161
IC11	TTL IC LS	74LS377	1	D3-7A377
IC12	TTL IC LS	74LS00	1	D3-7A000
IC13	TTL IC LS	74LS04	1	D3-7A004
IC14	COMPARITOR IC	LM311	1	D2-LM311
IC14S	8 PIN DIL SOCKET	8 PIN DIL SOCKET	1	E2-ES082
IC15	CMOS SWITCH QUAD	DG211	1	D2-DG211
IC15S	16 PIN DIL SOCKET	16 PIN DIL SOCKET	1	E2-ES161
IC16	LINEAR IC SINGLE	TLO71	1	D2-OL071
IC16S	8 PIN DIL SOCKET	8 PIN DIL SOCKET	1	E2-ES082
IC17	CMOS SWITCH QUAD	DG211	1	D2-DG211
IC17S	16 PIN DIL SOCKET	16 PIN DIL SOCKET	1	E2-ES161
IC18	LINEAR IC DUAL	TLO72	1	D2-OL072
IC18S	8 PIN DIL SOCKET	8 PIN DIL SOCKET	1	E2-ES082
IC19	LINEAR IC DUAL	NE5532	1	D2-05532
IC19S	8 PIN DIL SOCKET	8 PIN DIL SOCKET	1	E2-ES082
IC20	FILTER HYBRID L-PASS	KTR009	1	D2-KT009
IC21	FILTER HYBRID L-PASS	KTR009	1	D2-KT009
IC22	FILTER HYBRID L-PASS	KTR009	1	D2-KT009
P1	72P TYPE PRESET	72P 1K	1	A3-E2001
P2	72P TYPE PRESET	72P 50K	1	A3-E2050
PC1	PCB 2639	DN780 CONVERTOR	1	E6-02639
R1	5% RESISTOR	47R	1	A1-10047
R2	5% RESISTOR	10R	1	A1-10010
R3	5% RESISTOR	8K2	1	A1-18200
R4	5% RESISTOR	10K	1	A1-30010
R5	5% RESISTOR	1K5	1	A1-11500
R6	5% RESISTOR	4K7	1	A1-14700
R7	5% RESISTOR	120R	1	A1-10120
R8	5% RESISTOR	5K1	1	A1-15100
R9	5% RESISTOR	680R	1	A1-10680
R10	5% RESISTOR	5K6	1	A1-15600

DN780 CONVERTOR BOARD

REF	ITEM	VALUE	QTY	KTR:NO
R11	5% RESISTOR	5K6	1	A1-15600
R12	5% RESISTOR	2K2	1	A1-12200
R13	5% RESISTOR	220K	1	A1-30220
R14	5% RESISTOR	220K	1	A1-30220
R15	5% RESISTOR	2K2	1	A1-12200
R16	1% RESISTOR	2K55	1	A2-10255
R17	1% RESISTOR	2K55	1	A2-10255
R18	1% RESISTOR	3K09	1	A2-10309
R19	1% RESISTOR	3K09	1	A2-10309
R20	1% RESISTOR	2K55	1	A2-10255
R21	1% RESISTOR	2K55	1	A2-10255
R22	5% RESISTOR	5K6	1	A1-15600
R24	5% RESISTOR	3K9	1	A1-13900
R26	5% RESISTOR	5K6	1	A1-15600
R27	5% RESISTOR	3K9	1	A1-13900
R28	1% RESISTOR	3K09	1	A2-10309
R29	1% RESISTOR	2K55	1	A2-10255
R30	1% RESISTOR	2K55	1	A2-10255
R31	5% RESISTOR	5K6	1	A1-15600
R32	5% RESISTOR	5K6	1	A1-15600
R33	5% RESISTOR	10K	1	A1-30010
R34	5% RESISTOR	47K	1	A1-30047
R35	5% RESISTOR	100K	1	A1-30100
R36	5% RESISTOR	220K	1	A1-30220
R37	5% RESISTOR	68K0	1	A1-30068
R38	5% RESISTOR	68K0	1	A1-30068
RP1	5 ISOLATED RESIS PAK	5 ISOLATED 47R	1	A3-C5047
RP2	5 ISOLATED RESIS PAK	5 ISOLATED 47R	1	A3-C5047
RP3	5 ISOLATED RESIS PAK	5 ISOLATED 47R	1	A3-C5047
ST1	MOLEX 20P SHROUDED	2X10PIN SHROUDED SET	1	E2-BP203
ST2	MOLEX 8 PIN LATCHED	0.1 * 8PIN LATCHED	1	E2-BP082
ST3	MOLEX 8 PIN LATCHED	0.1 * 8PIN LATCHED	1	E2-BP082
ST4	MOLEX 3 PIN	0.1 3 PIN SET LATCH	1	E2-BP031
ST4A	MOLEX 2 PIN LATCHED	0.1 * 2PIN LATCHED	1	E2-BP021
ST4B	MOLEX 2 WAY PLUG	2W X 0.1 JUMP PLUG	1	E2-BS02A

DN780 DISPLAY BOARD

C1	CAP TANTALUM RADIAL	15/16V	1	B4-TB215
C3	CAP ELECTROLYTIC RAD	10/16V	1	B4-DB210
C4	CAPACITOR CERAMIC	47N	1	B2-2A047
C5	CAPACITOR CERAMIC	47N	1	B2-2A047
C6	CAP TANTALUM RADIAL	2.2/16V	1	B4-TB122
C7	CAP TANTALUM RADIAL	2.2/16V	1	B4-TB122
C9	CAP ELECTROLYTIC RAD	10/16V	1	B4-DB210
D1	RED LED SHOUEDED	RED LED SHOUEDED	1	D1-A5530
D2	RED LED SHOUEDED	RED LED SHOUEDED	1	D1-A5530
D3	RED LED SHOUEDED	RED LED SHOUEDED	1	D1-A5530
D4	RED LED SHOUEDED	RED LED SHOUEDED	1	D1-A5530
D5	GREEN LED SHOUEDED	GREEN LED SHOUEDED	1	D1-AQY90
D6	GREEN LED SHOUEDED	GREEN LED SHOUEDED	1	D1-AQY90
D7	GREEN LED SHOUEDED	GREEN LED SHOUEDED	1	D1-AQY90
D8	GREEN LED SHOUEDED	GREEN LED SHOUEDED	1	D1-AQY90
D9	GREEN LED SHOUEDED	GREEN LED SHOUEDED	1	D1-AQY90

DN780 DISPLAY BOARD

REF	ITEM	VALUE	QTY	KTR:NO
D10	GREEN LED SHOUEDED	GREEN LED SHOUEDED	1	D1-AQY90
D11	GREEN LED SHOUEDED	GREEN LED SHOUEDED	1	D1-AQY90
D12	DIODE	1N4148	1	D1-A4148
D13	DIODE	1N4148	1	D1-A4148
D14	RED LED 3mm ROUND	GL-3AR2	1	D1-AL209
D15	YELLOW LED 3mm	YELLOW LED 3mm	1	D1-AY209
D16	YELLOW LED 3mm	YELLOW LED 3mm	1	D1-AY209
D17	GREEN LED 3mm	GREEN LED 3mm	1	D1-AQY99
D18	GREEN LED 3mm	GREEN LED 3mm	1	D1-AQY99
D19	GREEN LED 3mm	GREEN LED 3mm	1	D1-AQY99
D20	GREEN LED 3mm	GREEN LED 3mm	1	D1-AQY99
D21	GREEN LED 3mm	GREEN LED 3mm	1	D1-AQY99
D22	GREEN LED 3mm	GREEN LED 3mm	1	D1-AQY99
D23	GREEN LED 3mm	GREEN LED 3mm	1	D1-AQY99
IC1	CURRENT SOURCE QUAD	1417/2580	1	D2-02580
IC2	CURRENT SINK QUAD	ULN 2068	1	D2-02068
IC3	CURRENT SINK QUAD	ULN 2068	1	D2-02068
IC4	CMOS IC	4514	1	D4-14514
IC4S	24 PIN DIL SOCKET	24 PIN DIL SOCKET	1	E2-ES241
IC5	CURRENT SINK QUAD	ULN 2068	1	D2-02068
IC6	CURRENT SINK QUAD	ULN 2068	1	D2-02068
IC7	7 SEG DISPLAY ORANGE	HD1107-O	1	D1-BHO07
IC8	7 SEG DISPLAY ORANGE	HD1107-O	1	D1-BHO07
IC9	7 SEG DISPLAY GREEN	HD1107-G	1	D1-BHG07
IC10	7 SEG DISPLAY GREEN	HD1107-G	1	D1-BHG07
IC11	7 SEG DISPLAY GREEN	HD1107-G	1	D1-BHG07
IC12	+1 SEG DISPLAY GREEN	HD1108-G	1	D1-BHG08
IC13	7 SEG DISPLAY GREEN	HD1107-G	1	D1-BHG07
IC14	+1 SEG DISPLAY GREEN	HD1108-G	1	D1-BHG08
IC15	7 SEG DISPLAY GREEN	HD1107-G	1	D1-BHG07
IC16	7 SEG DISPLAY GREEN	HD1107-G	1	D1-BHG07
IC17	7 SEG DISPLAY GREEN	HD1107-G	1	D1-BHG07
IC18	7 SEG DISPLAY GREEN	HD1107-G	1	D1-BHG07
IC19	7 SEG DISPLAY GREEN	HD1107-G	1	D1-BHG07
IC20	7 SEG DISPLAY GREEN	HD1107-G	1	D1-BHG07
IC21	7 SEG DISPLAY GREEN	HD1107-G	1	D1-BHG07
IC22	LINEAR IC DUAL	TLO72	1	D2-0L072
IC22S	8 PIN DIL SOCKET	8 PIN DIL SOCKET	1	E2-ES082
IC23	LEVEL DISPLAY DRIVER	LM3915	1	D2-L3915
L1	ZERO OHM LINK	ZERO OHM LINK	4	A3-A0001
P1	POT SING 4MM SFT PCB	10K LIN	1	A3-OC100
P2	72XW TYPE PRESET	72XW 20K	1	A3-D2020
PC1	PCB 2635	DN780 DISPLAY BRD	1	E6-02635
R1	5% RESISTOR	33R	1	A1-10033
R2	5% RESISTOR	33R	1	A1-10033
R3	5% RESISTOR	33R	1	A1-10033
R4	5% RESISTOR	33R	1	A1-10033
R5	5% RESISTOR	33R	1	A1-10033
R6	5% RESISTOR	33R	1	A1-10033
R7	5% RESISTOR	33R	1	A1-10033
R8	5% RESISTOR	33R	1	A1-10033
R9	5% RESISTOR	10K	1	A1-30010
R11	5% RESISTOR	82K	1	A1-30082



DN780 DISPLAY BOARD

REF	ITEM	VALUE	QTY	KTR: NO-
R12	5% RESISTOR	100R	1	A1-10100
R13	5% RESISTOR	100K	1	A1-30100
R14	5% RESISTOR	2K7	1	A1-12700
R15	5% RESISTOR	2K7	1	A1-12700
R16	5% RESISTOR	2K7	1	A1-12700
R17	5% RESISTOR	100K	1	A1-30100
R18	5% RESISTOR	1K	1	A1-11000
R19	5% RESISTOR	470R	1	A1-10470
R20	5% RESISTOR	680R	1	A1-10680
R21	5% RESISTOR	4K7	1	A1-14700
ST1	MOLEX 34P SHROUDED	2X17PIN SHROUDED SET	1	E2-BP341
ST2	MOLEX 6 PIN STRAIGHT	0.156 * 6PIN STRAIT	1	E2-BP064
ST3	MOLEX 6 PIN	0.1 X 6PIN SET LATCH	1	E2-BP061
SW1	MOMENTRY PUSH SWITCH	ANTHRACITE [ 9 ]	1	E1-BG125
SW2	MOMENTRY PUSH SWITCH	ANTHRACITE [ 8 ]	1	E1-BG124
SW3	MOMENTRY PUSH SWITCH	ANTHRACITE [ 7 ]	1	E1-BG123
SW4	MOMENTRY PUSH SWITCH	ANTHRACITE [ 4 ]	1	E1-BG120
SW5	MOMENTRY PUSH SWITCH	ANTHRACITE [ 5 ]	1	E1-BG121
SW6	MOMENTRY PUSH SWITCH	ANTHRACITE [ 6 ]	1	E1-BG122
SW7	MOMENTRY PUSH SWITCH	ANTHRACITE [ 3 ]	1	E1-BG119
SW8	MOMENTRY PUSH SWITCH	ANTHRACITE [ 2 ]	1	E1-BG118
SW9	MOMENTRY PUSH SWITCH	ANTHRACITE [ 1 ]	1	E1-BG117
SW10	MOMENTRY PUSH SWITCH	DARK GREY [ SEQ ]	1	E1-BG129
SW11	MOMENTRY PUSH SWITCH	ANTHRACITE [ 0 ]	1	E1-BG116
SW12	MOMENTRY PUSH SWITCH	DARK GREY [ STO ]	1	E1-BG128
SW13	MOMENTRY PUSH SWITCH	ANTHRACITE [ + ]	1	E1-BG114
SW14	MOMENTRY PUSH SWITCH	ANTHRACITE [ - ]	1	E1-BG115
SW15	MOMENTRY PUSH SWITCH	DARK GREY MARQUART	1	E1-BG113
SW16	MOMENTRY PUSH SWITCH	DARK GREY MARQUART	1	E1-BG113
SW17	MOMENTRY PUSH SWITCH	DARK GREY MARQUART	1	E1-BG113
SW18	MOMENTRY PUSH SWITCH	DARK GREY MARQUART	1	E1-BG113
SW19	MOMENTRY PUSH SWITCH	DARK GREY MARQUART	1	E1-BG113
SW20	MOMENTRY PUSH SWITCH	DARK GREY MARQUART	1	E1-BG113
SW21	MOMENTRY PUSH SWITCH	DARK GREY MARQUART	1	E1-BG113
SW22	MOMENTRY PUSH SWITCH	DARK GREY [ REV ]	1	E1-BG127
SW23	MOMENTRY PUSH SWITCH	DARK GREY [ IN ]	1	E1-BG126

DN780 AUDIO IN/OUT BOARD

C2	CAPACITOR PLASTIC 5%	1N	1	B1-11000
C3	CAPACITOR PLASTIC 5%	1N	1	B1-11000
C4	CAPACITOR CERAMIC	15P	1	B2-10015
C5	CAPACITOR CERAMIC	82PF	1	B2-10082
C8	CAP ELECTROLYTIC RAD	470/16V	1	B4-DB347
C9	CAP ELECTROLYTIC RAD	470/16V	1	B4-DB347
C12	CAP ELECTROLYTIC RAD	470/16V	1	B4-DB347
C13	CAP ELECTROLYTIC RAD	470/16V	1	B4-DB347
C14	CAPACITOR CERAMIC	47N	1	B2-2A047
C15	CAPACITOR CERAMIC	47N	1	B2-2A047
C16	CAPACITOR CERAMIC	47N	1	B2-2A047
C17	CAPACITOR CERAMIC	47N	1	B2-2A047
IC1	LINEAR IC DUAL	NE5532	1	D2-05532
IC1S	8 PIN DIL SOCKET	8 PIN DIL SOCKET	1	E2-ES082
IC2	LINEAR IC DUAL	NE5532	1	D2-05532

DN780 AUDIO IN/OUT BOARD

REF	ITEM	VALUE	QTY	KTR: NO
IC2S	8 PIN DIL SOCKET	8 PIN DIL SOCKET	1	E2-ES082
L1	ZERO OHM LINK	ZERO OHM LINK	10	A3-A0001
L2	PRE CUT WIRE	BLUE 7/0.2 - 60MM	1	G3-BIBEL
P1	PIHER VER PRESET	220R	1	A3-G1220
P2	72X TYPE PRESET	72X 10K	1	A3-H2010
P3	72X TYPE PRESET	72X 10K	1	A3-H2010
PC1	PCB 2641	DN780 AUDIO IN/OUT	1	E6-02641
R3	1% RESISTOR	1K	1	A2-10100
R4	1% RESISTOR	10K	1	A2-11000
R5	1% RESISTOR	10K	1	A2-11000
R6	1% RESISTOR	10K	1	A2-11000
R7	5% RESISTOR	1K	1	A1-11000
R8	1% RESISTOR	1K	1	A2-10100
R9	1% RESISTOR	10K	1	A2-11000
R10	5% RESISTOR	1K	1	A1-11000
R11	1% RESISTOR	10K	1	A2-11000
R12	5% RESISTOR	2K7	1	A1-12700
R13	5% RESISTOR	1K2	1	A1-11200
R14	5% RESISTOR	2K7	1	A1-12700
R15	5% RESISTOR	2K7	1	A1-12700
R16	5% RESISTOR	1K2	1	A1-11200
R17	5% RESISTOR	2K7	1	A1-12700
ST1	XLR (3) INPUT	PANEL MOUNT PCB HORZ	1	E2-AP034
ST2	XLR OUTPUT (3)	PANEL MOUNT PCB HORZ	1	E2-AS034
ST3	XLR OUTPUT (3)	PANEL MOUNT PCB HORZ	1	E2-AS034
ST4	MOLEX 6 PIN	0.1 X 6PIN SET LATCH	1	E2-BP061
ST5	MOLEX 6 PIN	0.1 X 6PIN SET LATCH	1	E2-BP061
ST6	MOLEX 8 PIN LATCHED	0.1 * 8PIN LATCHED	1	E2-BP082
ST8	MOLEX 6 PIN	0.1 X 6PIN SET LATCH	1	E2-BP061
ST9	MOLEX 6 PIN	0.1 X 6PIN SET LATCH	1	E2-BP061
T2	AUDIO TRANSFORMER	OUT CANNED PIKATRON	1	E5-TA007
T3	AUDIO TRANSFORMER	OUT CANNED PIKATRON	1	E5-TA007
ZA2	SCREW	No 4 SELF TAP	3	F1-KR049
ZB2	WASHER	NYLON WASHER	3	F1-CB035
ZB3	SHAKEPROOF WASHER	M4 BZP	1	F1-DC042
ZC1	NUTS	M4 CAD + PASS	1	F1-AC002
ZD1	PILLAR 35MM	M4 THREAD+TAPPED	1	E4-P4B35

DN780 POWER SUPPLY BOARD

C1	CAP ELECTROLYTIC RAD	470/35V	1	B4-DD347
C2	CAP ELECTROLYTIC RAD	470/35V	1	B4-DD347
C3	CAP ELECTROLYTIC RAD	15000/16V	1	B4-DB515
C4	CAPACITOR CERAMIC	47N	1	B2-2A047
C5	CAPACITOR CERAMIC	47N	1	B2-2A047
C6	CAPACITOR CERAMIC	47N	1	B2-2A047
C7	CAPACITOR CERAMIC	47N	1	B2-2A047
C8	CAP ELECTROLYTIC RAD	6800/16V	1	B4-DB468
D1	DIODE	1N4002	1	D1-A4002
D2	DIODE	1N4002	1	D1-A4002
D3	DIODE	1N4002	1	D1-A4002
D4	DIODE	1N4002	1	D1-A4002
D5	DIODE	1N4002	1	D1-A4002
D6	DIODE	1N4002	1	D1-A4002

DN780 POWER SUPPLY BOARD

REF	ITEM	VALUE	QTY	KTR:NO-
D7	DIODE	1N4002	1	D1-A4002
D8	DIODE	1N4002	1	D1-A4002
D9	BRIDGE DIODE 6 AMP	BR64	1	D1-AP006
D10	DIODE	1N4002	1	D1-A4002
D11	DIODE	1N4002	1	D1-A4002
F1	FUSE HOLDER	OPEN PCB MOUNT	1	E3-A0100
F2	FUSE HOLDER	OPEN PCB MOUNT	1	E3-A0100
F3	FUSE HOLDER	OPEN PCB MOUNT	1	E3-A0100
FF1	FUSE	500mA TIME DELAY	1	E3-BA500
FF2	FUSE	500mA TIME DELAY	1	E3-BA500
FF3	FUSE	5A TIME DELAY	1	E3-BQ005
FF4	FUSE	1.0A TIME DELAY	2	E3-BA010
H1	HEATSINK	TV5	1	E8-HOTV5
H2	HEATSINK	TV5	1	E8-HOTV5
H3	HEATSINK	TV6	1	E8-HOTV6
H4	HEATSINK	TV5	1	E8-HOTV5
IC1	REGULATOR 15V	78M15 15V TO220	1	D2-78M15
IC2	REGULATOR 15V	78M15 15V TO220	1	D2-78M15
IC3	REGULATOR 5V	78M05 5V TO220	1	D2-78M05
IC4	REGULATOR 5V 5A	78H05 5V 5A T03	1	D2-78H05
L1	ZERO OHM LINK	ZERO OHM LINK	4	A3-A0001
PC1	PCB 2642	DN780 PSU BRD	1	E6-02642
R1	5% RESISTOR	470R	1	A1-10470
R2	5% RESISTOR	100R	1	A1-10100
ST1	MOLEX 6 PIN STRAIGHT	0.156 * 6PIN STRAIT	1	E2-BP064
ST2	MOLEX 6 PIN STRAIGHT	0.156 * 6PIN STRAIT	1	E2-BP064
ST3	MOLEX 6 PIN STRAIGHT	0.156 * 6PIN STRAIT	1	E2-BP064
ST4	MOLEX 6 PIN	0.1 X 6PIN SET LATCH	1	E2-BP061
ST5	MOLEX 2 PIN LATCHED	0.1 * 2PIN LATCHED	1	E2-BP021
ST6	T03 SOCKET	T03 SOCKET	1	E2-ES031
ST7	IEC MAINS INPUT	WITH FUSE HOLDER	1	E2-DS033
SW1	LATCHING PUSH SWITCH	ALPS MAINS TYPE	1	E1-BF211
SW2	SLIDE SWITCH C&K	2P2W PCB	1	E1-CD221
SW3	SLIDE SWITCH C&K	2P2W PCB	1	E1-CD221
T1	MAINS TRANSFORMER	TORODIAL DN70	1	E5-TM002
ZA1	SCREW	M3 X 10 P/HD C+P	3	F1-GB102
ZA2	SCREW	M3 X 6 P/HD BZP	1	F1-GB062
ZA3	SCREW	M3 X 12 P/HD C+P	1	F1-GB122
ZA4	M5 X 45 POZI PAN	M5 X 45 BZP	1	F1-GD452
ZB1	SHAKEPROOF WASHER	M3 BZP	6	F1-DB032
ZB2	SHAKEPROOF WASHER	M5 SHAKEPROOF	1	F1-DD052
ZB3	MUDGUARD WASHER	M5 1" DIA	1	F1-CC252
ZC1	NUTS	M3 BZP	5	F1-AB002
ZC2	M5 NUTS BZP	M5 NUTS	1	F1-AD002
ZD1	PILLAR 14MM	M3 THREAD + TAPPED	1	E4-P3B14
ZF1	TYRAPS	SMALL TYRAPS	3	H1-CA001
ZI1	MOUNTING KITS	T03 SILICONE WASHERS	1	H1-EA002

DN780 FRONT PANEL ASSEMBLY

REF	ITEM	VALUE	QTY	KTR:NO
C1	CAPACITOR CERAMIC	47N	1	B2-2A047
K1	SIFAM KNOB COLLET	11MM 4MM SFT BLK LIN	1	E4-AC003
K2	SIFAM CAP	11MM GREY + LINE	1	E4-B9004
ZA1	SCREW	M3 X 10 RSD CSK CHRO	3	F1-FB101
ZA2	SCREW	M3 X 6 RSD CSK CHROM	5	F1-FB061
ZA3	TAMPERROOF SCREW	M3 * 12MM	1	F1-PB122
ZB1	SHAKEPROOF WASHER	M3 BZP	6	F1-DB032
ZB2	SOLDER TAG	M3 TIN	2	F1-TB004
ZC1	NUTS	M3 BZP	1	F1-AB002
ZC2	LOCKNUT M3	LOCKNUT M3	1	F1-AB202
ZD1	NYLON SPACER	6-6-M3 CLR SPACER	8	E4-POE55
ZH1	DN780 FRONT PANEL	DN780 FRONT PANEL	1	E7-F7801

DN780 CHASSIS ASSEMBLY

FA1	FAN MICRONEL	52MM 12VAC	1	E5-F0001
FA2	FAN FINGER GUARD	52MM FAN TYPE	1	E8-F0001
K1	RECTANGULAR CAP	SMALL RED	1	E4-B2003
ST1	MOLEX 2WAY SKT HSG	0.1 2WAY SOCKET HSG	1	E2-CS021
ST1A	MOLEX SOCKET TERM	MOLEX TERMINAL	2	E2-CS011
ZA1	THUMB SCREW COARSE	M4*10MM	3	F1-VB102
ZA2	SCREW	M3 X 10 P/HD C+P	4	F1-GB102
ZA3	SCREW	M3 X 6 P/HD BZP	14	F1-GB062
ZA4	SCREW	M4 X 6 P/HD CHROME	8	F1-GC061
ZA5	SCREW	M3 X 6 RSD CSK CHROM	4	F1-FB061
ZA6	SCREW	M3 X 10 RSD CSK CHRO	5	F1-FB101
ZB1	WASHER PLASTIC RED	M4 CLIP TYPE	3	F1-CC039
ZB2	SHAKEPROOF WASHER	M3 BZP	22	F1-DB032
ZB3	SHAKEPROOF WASHER	M4 BZP	8	F1-DC042
ZC1	NUTS	M3 BZP	8	F1-AB002
ZC2	NUTS	M4 CAD + PASS	4	F1-AC002
ZD1	PILLAR 35MM	M4 THREAD+TAPPED	2	E4-P4B35
ZF1	TYRAPS	SMALL TYRAPS	2	H1-CA001
ZH1	DN780 CHASSIS	DN780 CHASSIS	1	E8-A0015
ZH2	DN780 COVER PAIR	DN780 COVERS	1	E8-B0015
ZH3	DN780 REAR PANEL	DN780 REAR PANEL	1	E7-R7801
ZH4	DN 780 HINGE	DN780 HINGE	2	E8-C0009

DN780 CABLING KIT

CA1A	16 WAY SOCKET	16WAY SOC STD RIBBON	2	E2-CP161
CA2A	16 WAY SOCKET	16WAY SOC STD RIBBON	2	E2-CP161
CA3A	20 WAY IDC RIB SOCKT	20WAY IDC RIB SOCKET	2	E2-CP201
CA4A	MOLEX 6WAY SKT IDC	0.156 * 6 IDC SKT	2	E2-CS064
CA5A	34 WAY IDC CONNECTOR	34 WAY IDC CONNECTOR	2	E2-CP341
CA6A	8WAY CABLE+PLUG+PLUG	8 WAY 0.1 TYPE	1	E2-GS081
CA7A	MOLEX 6WAY SKT IDC	0.156 * 6 IDC SKT	2	E2-CS064
CA8A	6WAY CABLE+PLUG+PLUG	6 WAY 0.156 TYPE	1	E2-GS062
CA9A	6WAY CABLE+PLUG+PLUG	6 WAY 0.1 TYPE	1	E2-GS061
CA10A	8WAY CABLE+PLUG+PLUG	8 WAY 0.1 TYPE	1	E2-GS081
CA11A	MOLEX 6WAY SKT IDC	0.1 *6 IDC SOCKET	2	E2-CS063

**DN780 REMOTE PCB ASSEMBLY**

REF	ITEM	VALUE	QTY	KTR:NO
D1	RED LED 3mm ROUND	GL-3AR2	1	D1-AL209
D2	RED LED 3mm ROUND	GL-3AR2	1	D1-AL209
D3	RED LED 3mm ROUND	GL-3AR2	1	D1-AL209
D4	RED LED 3mm ROUND	GL-3AR2	1	D1-AL209
D5	RED LED 3mm ROUND	GL-3AR2	1	D1-AL209
L1	PRE CUT WIRE	BLUE 7/0.2 - 60MM	4	G3-BIBE1
PC1	PCB 2643	DN780 REMOTE	1	E6-02643
Q1	TRANSISTOR	BC184 OR EQUIV	1	D1-C184C
Q2	TRANSISTOR	BC184 OR EQUIV	1	D1-C184C
Q3	TRANSISTOR	BC184 OR EQUIV	1	D1-C184C
Q4	TRANSISTOR	BC184 OR EQUIV	1	D1-C184C
Q5	TRANSISTOR	BC184 OR EQUIV	1	D1-C184C
R1	ZERO OHM LINK	ZERO OHM LINK	1	A3-A0001
R2	5% RESISTOR	10K	1	A1-30010
R3	5% RESISTOR	10K	1	A1-30010
R4	5% RESISTOR	330R	1	A1-10330
R5	5% RESISTOR	10K	1	A1-30010
R6	5% RESISTOR	330R	1	A1-10330
R7	5% RESISTOR	10K	1	A1-30010
R8	5% RESISTOR	330R	1	A1-10330
R9	5% RESISTOR	10K	1	A1-30010
R10	5% RESISTOR	330R	1	A1-10330
R11	5% RESISTOR	10K	1	A1-30010
R12	5% RESISTOR	330R	1	A1-10330
R13	5% RESISTOR	10K	1	A1-30010
ST1	15 WAY DEE SOCKET	SOLDER TYPE	1	E2-CP152
ST1A	15 WAY DEE COVER	CT15	1	E2-CC151
SW1	MOMENTRY PUSH SWITCH	DARK GREY MARQUART	1	E1-BG113
SW2	MOMENTRY PUSH SWITCH	DARK GREY MARQUART	1	E1-BG113
VR1	ALPS FADER 60MM	10KB 60MM (DN780)	1	A3-MF100
VR2	ALPS FADER 60MM	10KB 60MM (DN780)	1	A3-MF100
VR3	ALPS FADER 60MM	10KB 60MM (DN780)	1	A3-MF100
VR4	ALPS FADER 60MM	10KB 60MM (DN780)	1	A3-MF100
ZF1	TYRAPS	SMALL TYRAPS	1	H1-CA001
<b>DN780 REMOTE MAIN ASSEMBLY</b>				
K1	FADER KNOB (DN780)	FADER KNOB	4	E4-AP300
ZA1	SCREW	M3 X 6 RSD CSK CHROM	4	F1-FB061
ZB1	SHAKEPROOF WASHER	M3 BZP	4	F1-DB032
ZB2	WASHER	NYLON WASHER	4	F1-CB035
ZC1	NUTS	M3 BZP	4	F1-AB002
ZD1	NYLON SPACER	6-6-M3 CLR SPACER	4	E4-POE55
ZF1	HEYCO CABLE RESTRIAN		1	H1-CA002
ZF2	PUSH ON RUBBER FEET	RUBBER FEET	4	H1-F0002
ZH1	DN780 REMOTE BASE		1	E8-A0016
ZH2	DN780 REMOTE FACE/PL		1	E8-A0017
<b>DN780 PACKING KIT</b>				
SF1	FUSE	500mA TIME DELAY	2	E3-BA500
SF2	FUSE	5A TIME DELAY	2	E3-BQ005
SF3	FUSE	1.0A TIME DELAY	2	E3-BA010
ZA1	SCREW	M4 X 6 P/HD CHROME	4	F1-GC061
ZL1	MAINS PLUG LEAD	MAINS LEAD IEC/FREE	1	E2-DP031
ZP1	DN780 EPS PACK	EPS PACK	1	H1-PPD4U
ZP2	533 X 383 X 195MM	DN780 BOX	1	H1-CE195

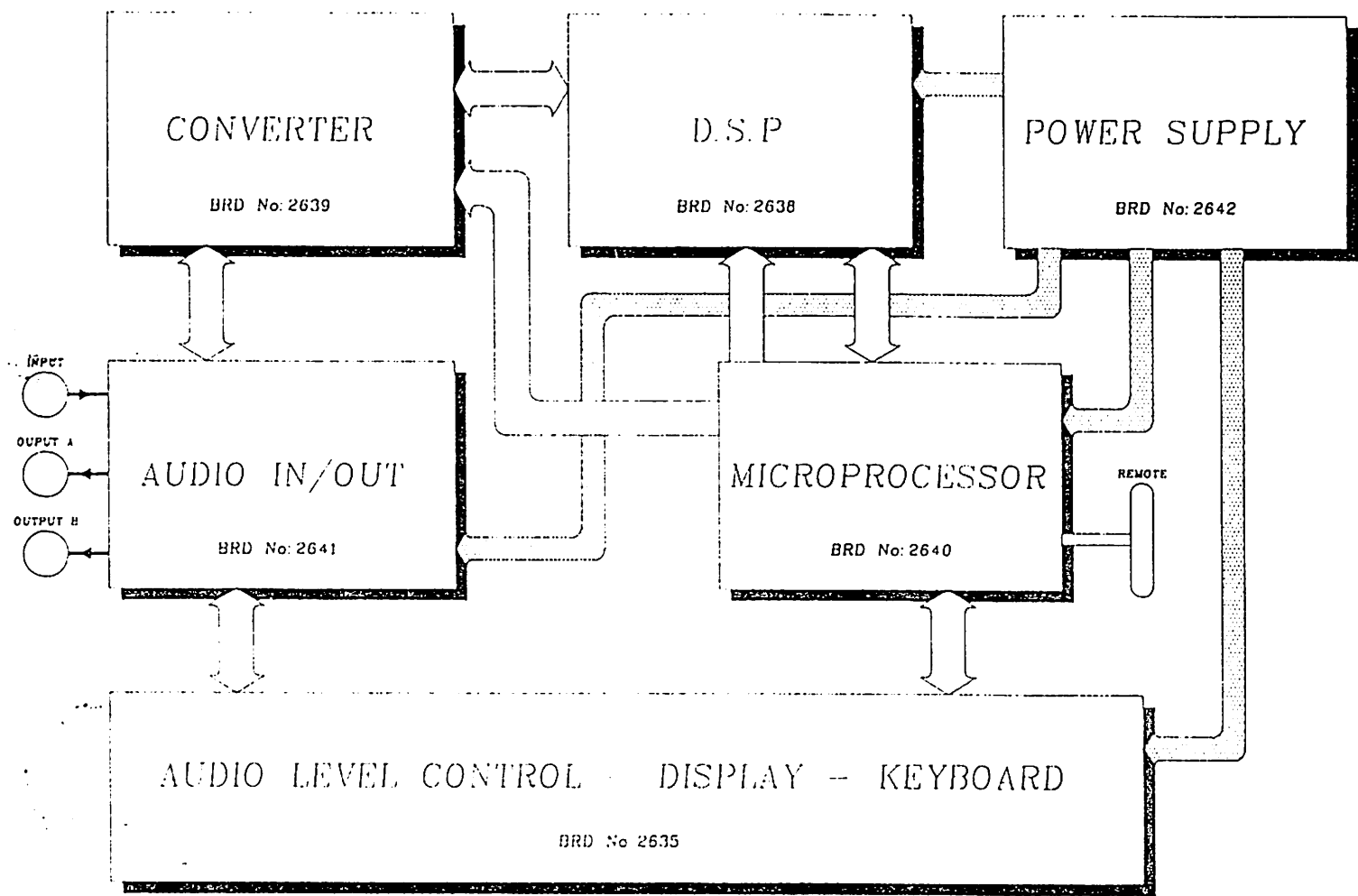

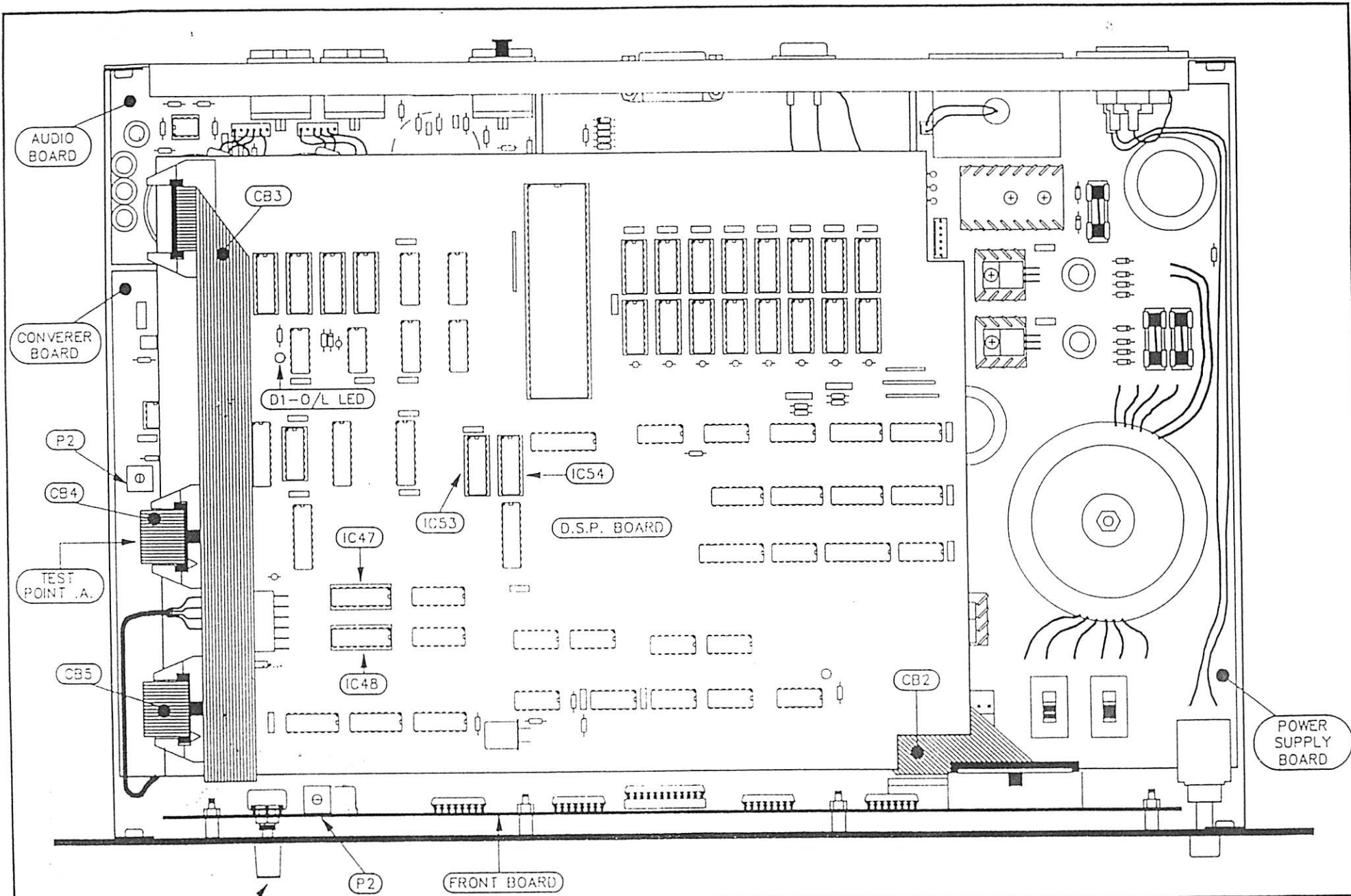

DWG 0007

DN780	PLAN VIEW	No.2	03.JUN.85
-------	-----------	------	-----------

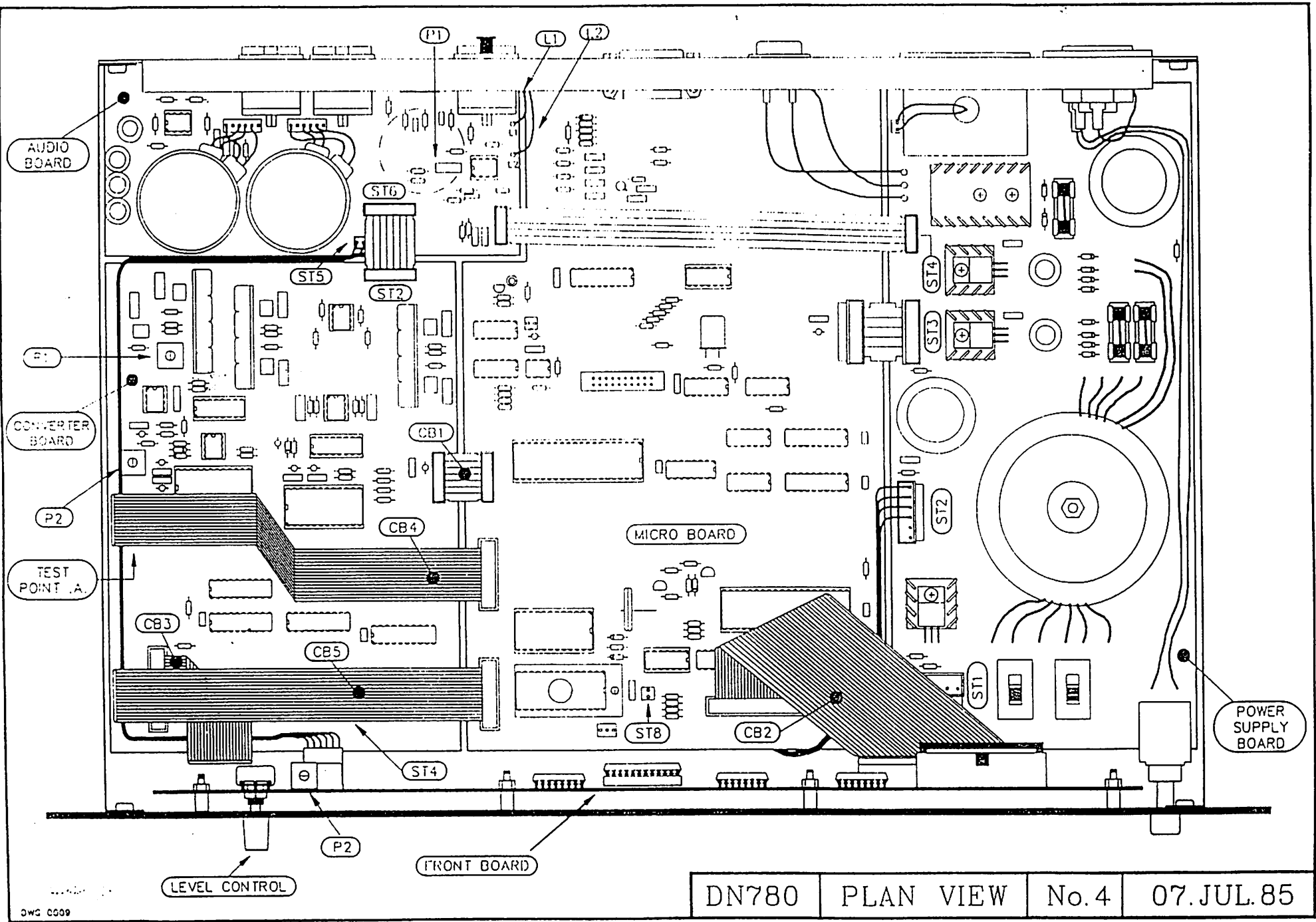

3WG 0509

DN780	PLAN VIEW	No. 4	07.JUL.85
-------	-----------	-------	-----------



15 WAY DEE TYPE SOCKET

OV	3 0	BROWN
LEV	11 0	RED
RSEQ	6 0	ORANGE
REM3	14 0	YELLOW
DECAY	1 0	GREEN
HF	2 0	BLUE
REM5	12 0	VIOLET
REM2	15 0	GREY
+5V	4 0	WHITE
LEVEL	9 0	PINK
REM4	13 0	U.BLUE
REM1	8 0	RED/BLUE
REMOTE	7 0	RED/GREEN
PREDELAY	10 0	RED/YELLOW
OV	5 0	BLACK

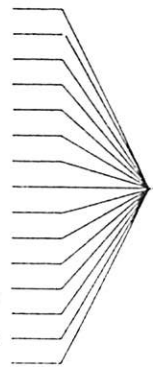

15 WAY CABLE

BROWN	1
RED	2
ORANGE	3
YELLOW	4
GREEN	5
BLUE	6
VIOLET	7
LT/BLUE	8
WHITE	9
PINK	10
GREY	11
RED/BLUE	12
RED/GREEN	13
RED/YELLOW	14
BLACK	15

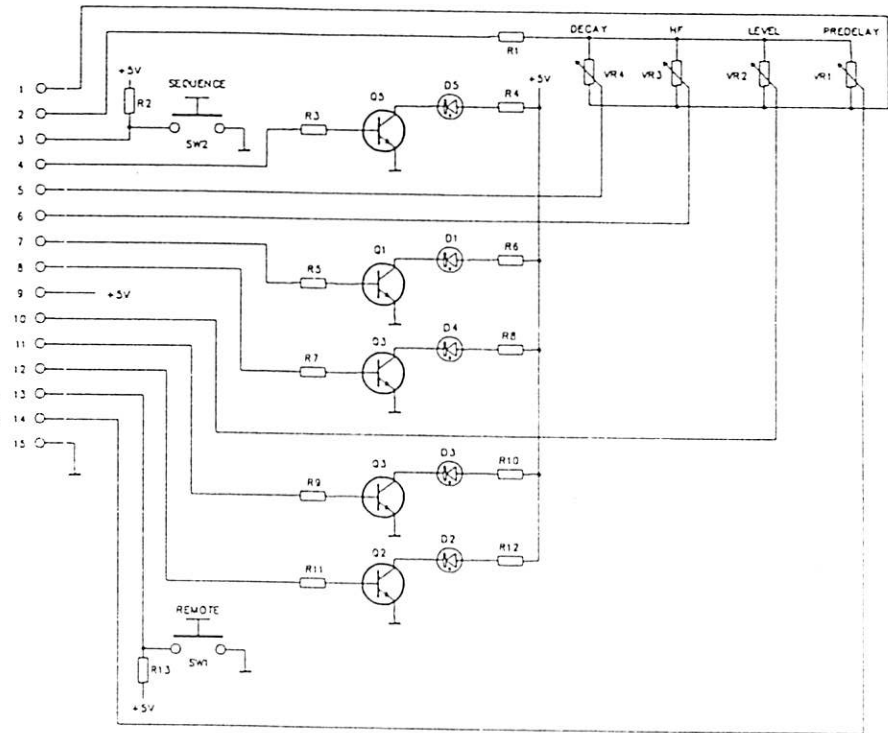

DN780 REMOTE UNIT BRD: 2643/1 28.FEB.85

TRANSFORMER INPUT OPTION

OMIT. P1,R3-R11,C2-C5,Link A  
 REPLACE WITH LINKS. R5,R11  
 ADDITIONAL COMPONENTS. R1,R2,C1

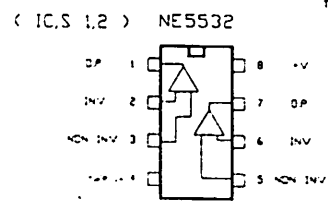
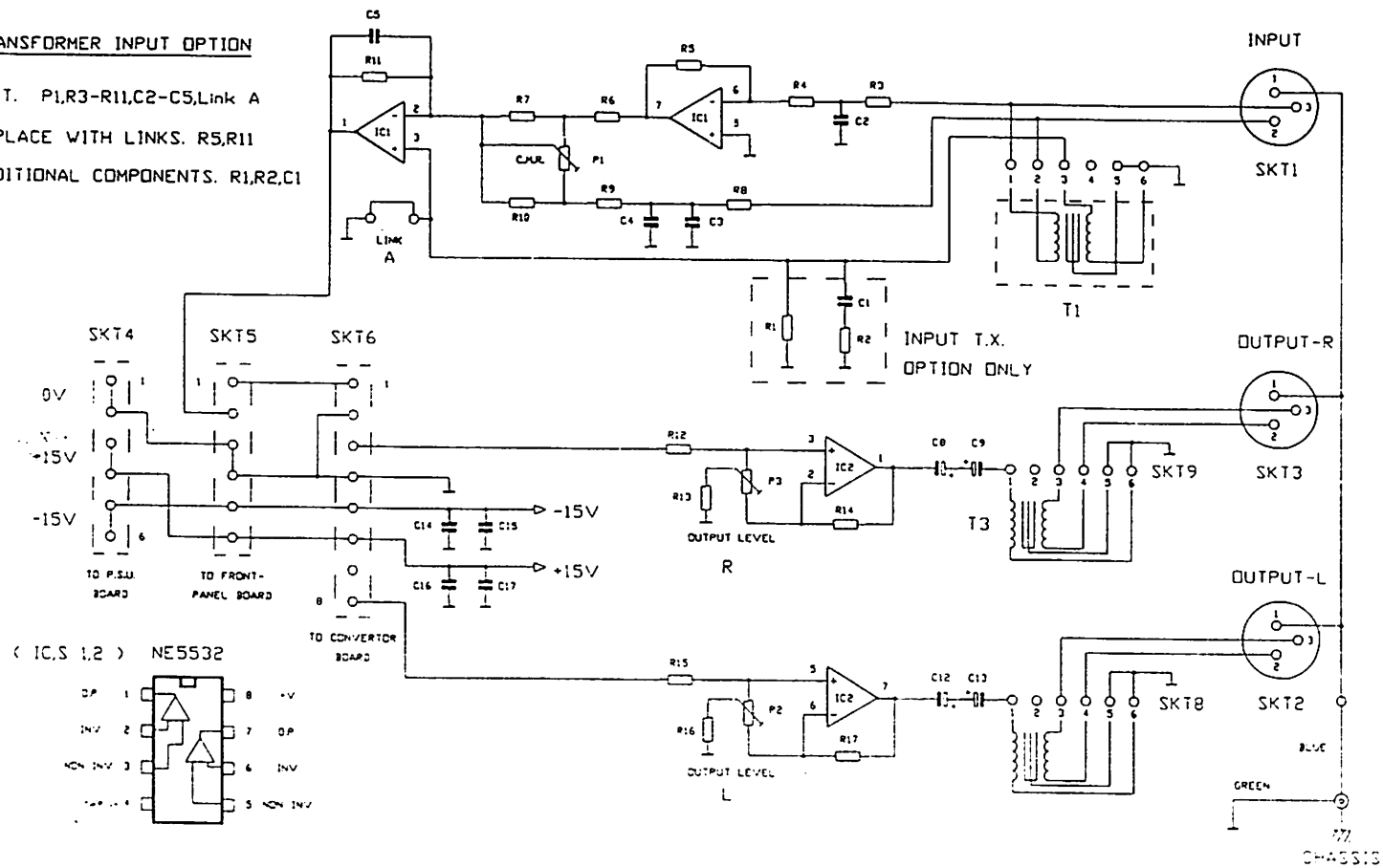

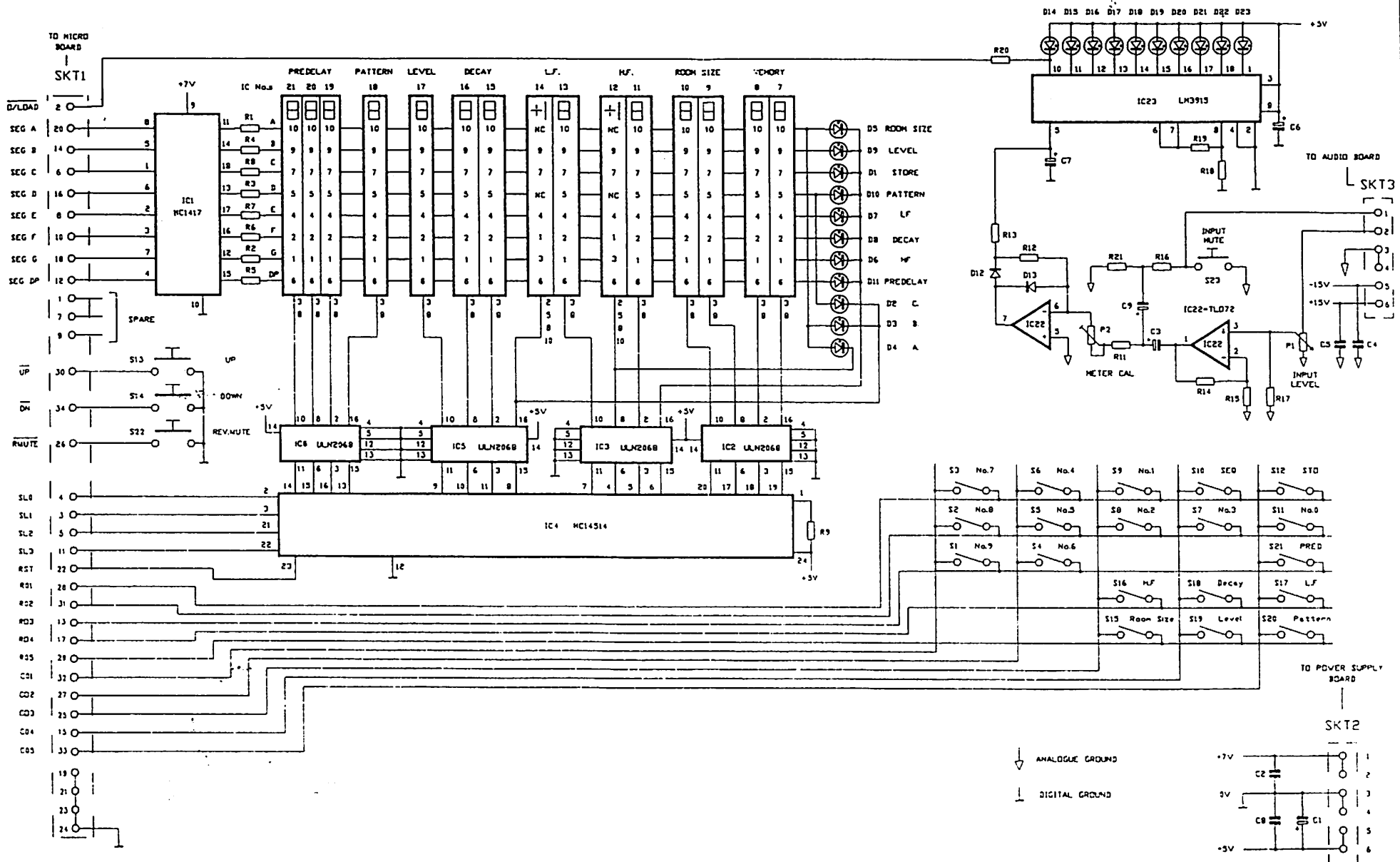

DN780 FRONT PANEL BOARD BRD: 2635/4 27. AUG. 85

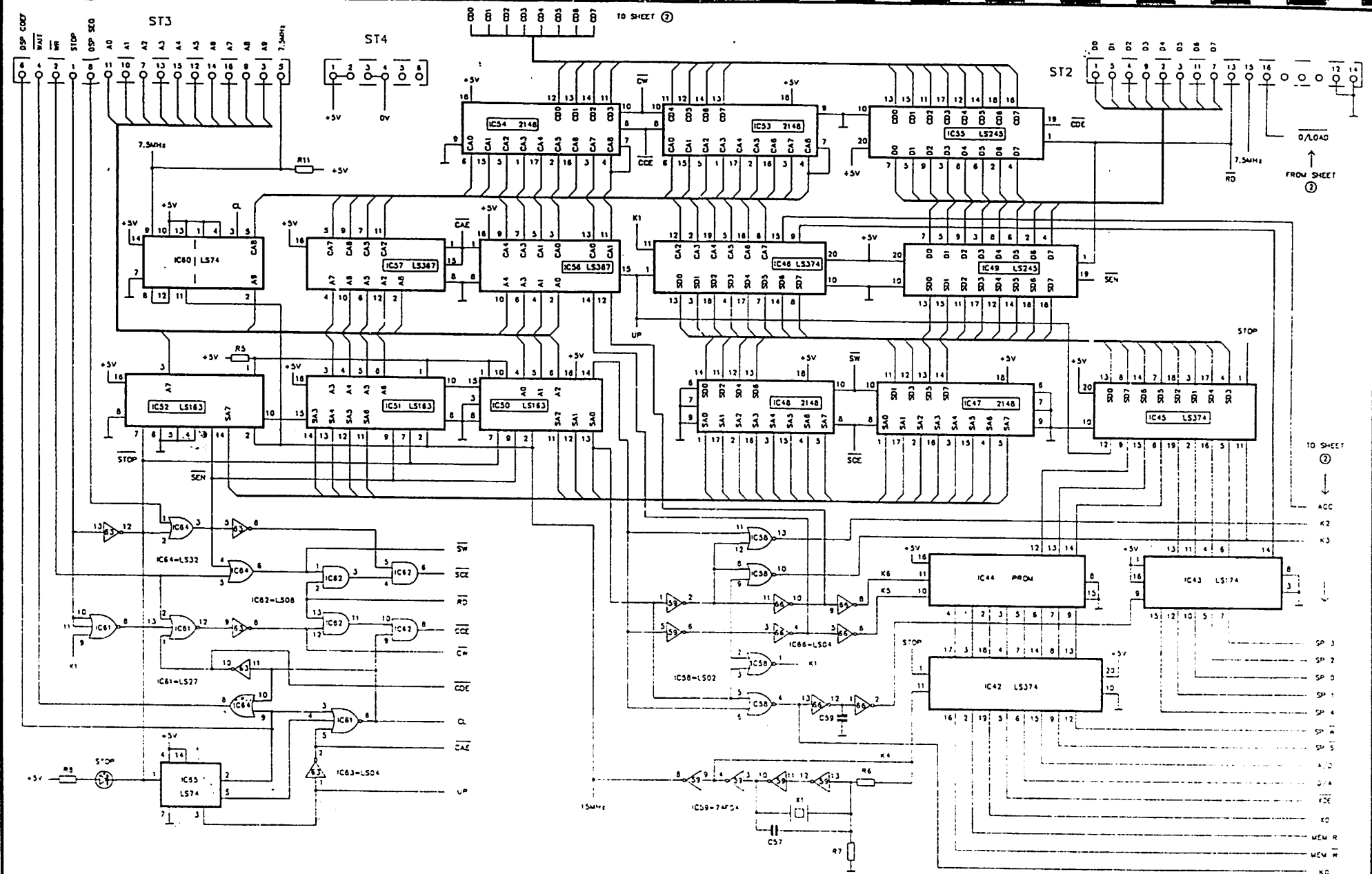

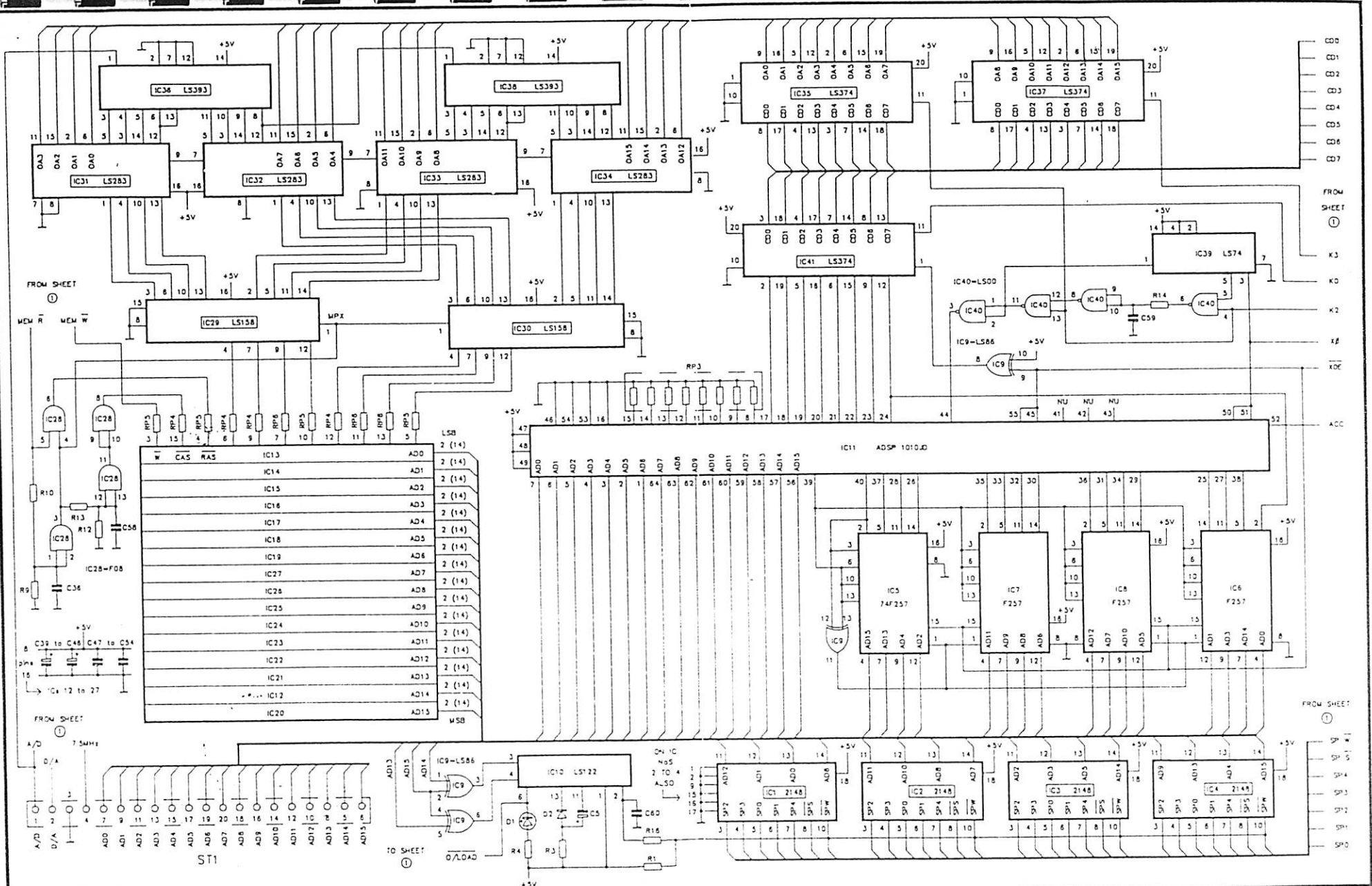

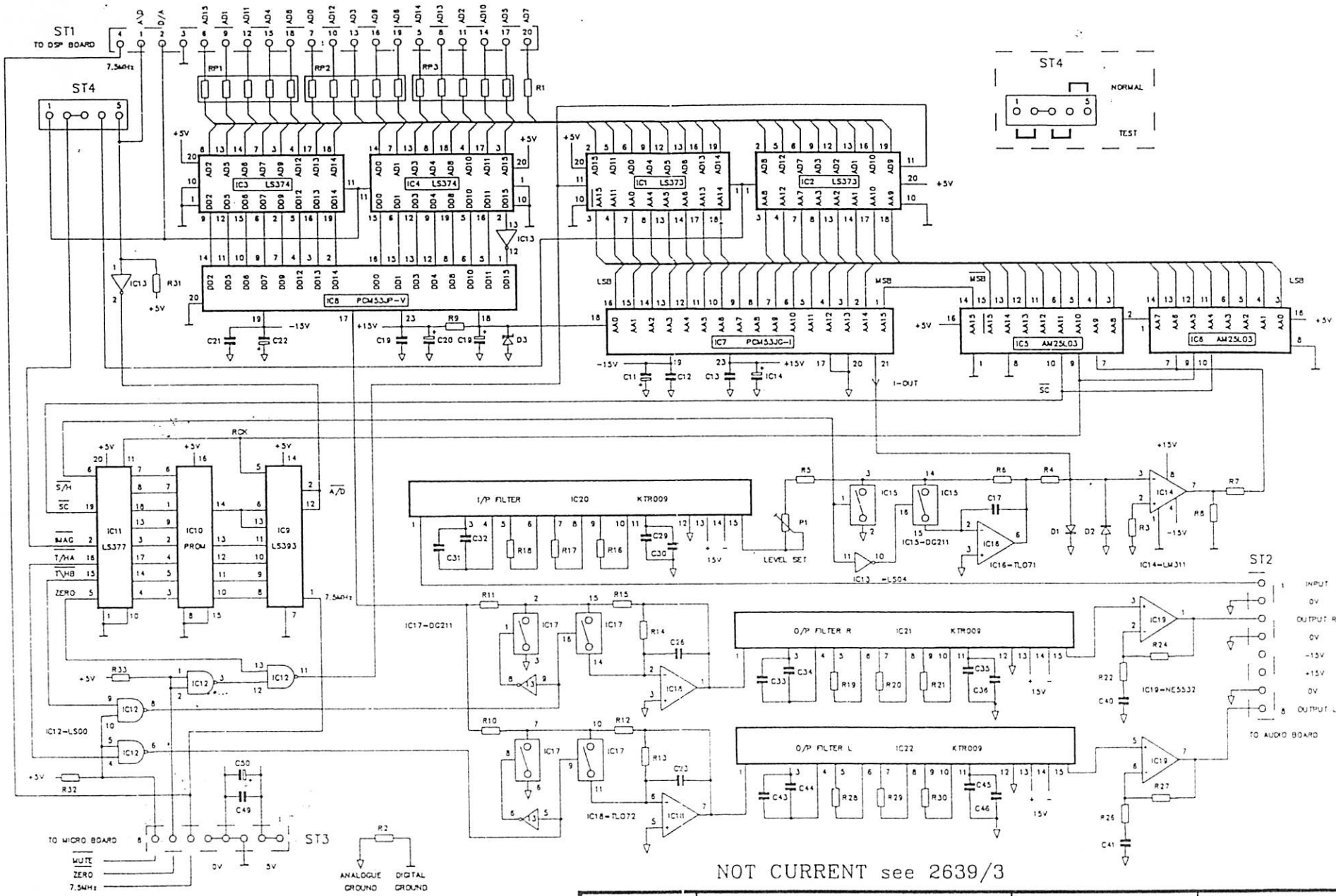

NOT CURRENT see 2639/3

DN780 CONVERTER SECTION BRD: 2639/2 27.AUG.85

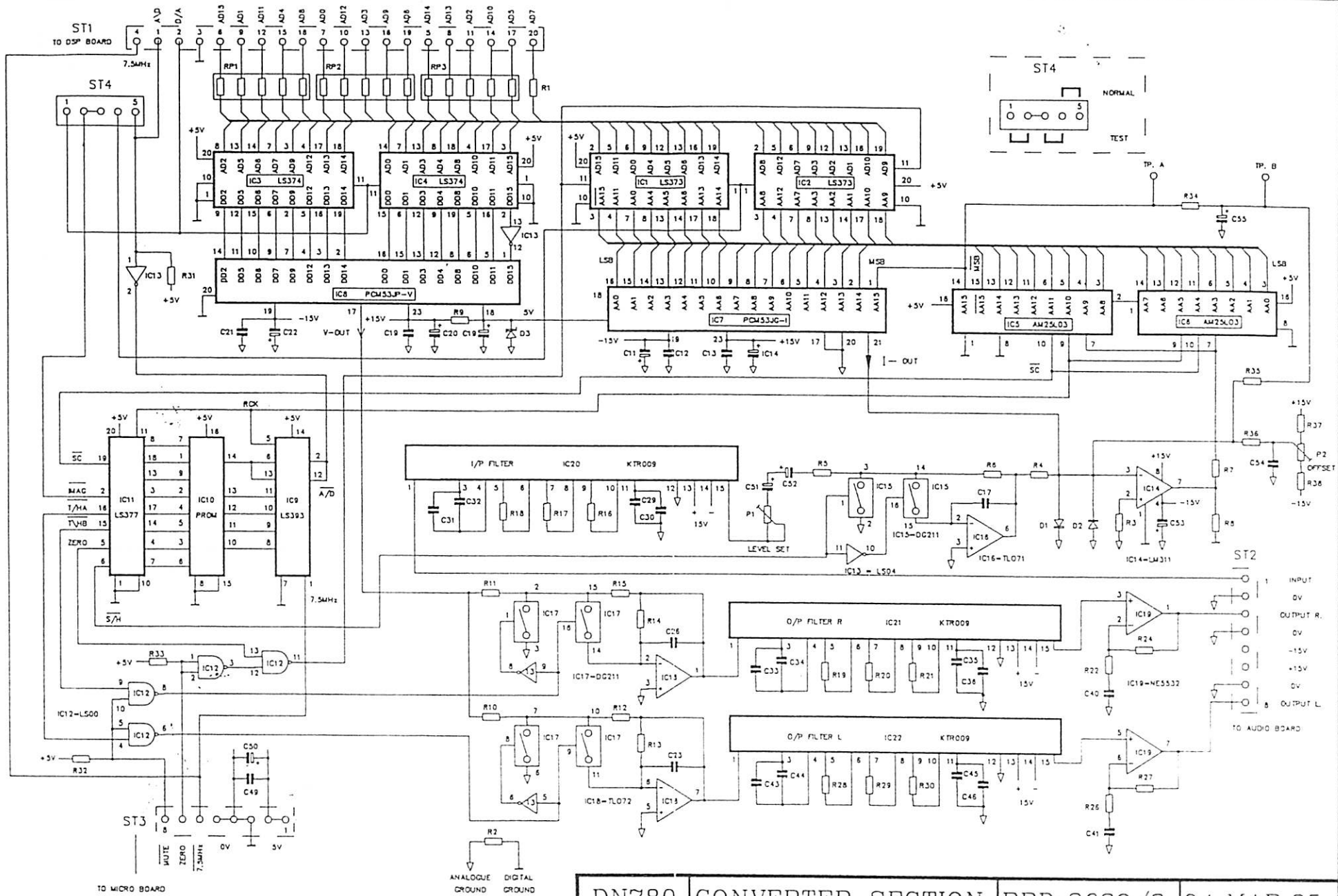

DN780 CONVERTER SECTION BRD: 2639/3 04.MAR.85

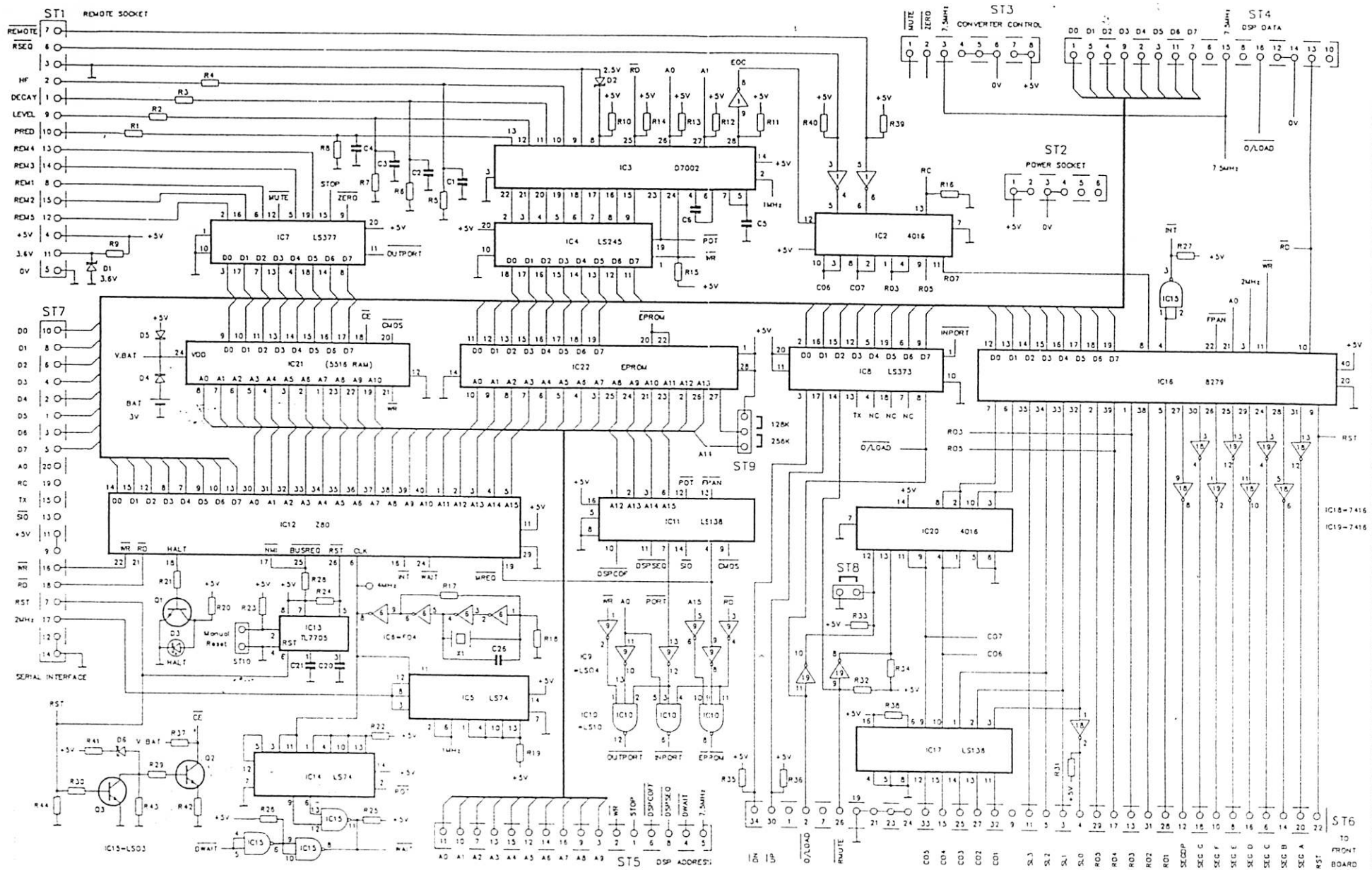

DN780 MICROPROCESSOR SECTION BRD: 2640/3 28 FEB. 85



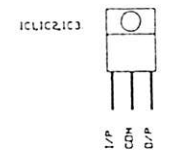
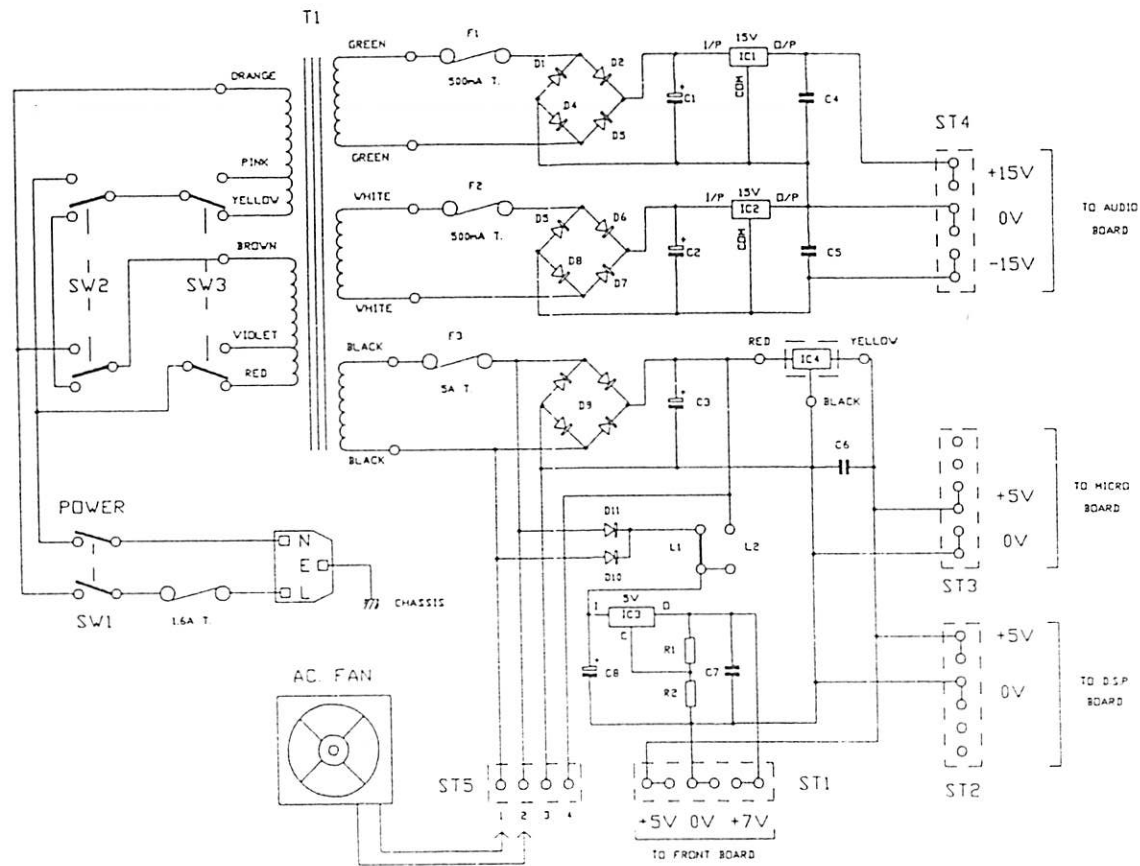

DN780 POWER SUPPLY SECTION BRD: 2642/2 27.FEB.85

# KLARK TEKNIK



AUDIO EQUALISATION



SPECTRUM ANALYSIS



DIGITAL AUDIO

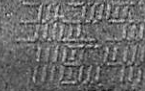

AUDIO DELAY



AUDIO MIXING



MONITOR  
LOUDSPEAKERS