

- Solid State Construction — Silicon Planar Transistors
- 60db Signal to Noise Ratio
- 6 Principal Inputs with Speech-Music Switches
- Compact 3½" High — Rack Mount or Portable
- Output Transformer — Regulated Power Supply
- Illuminated VU Meter — XL Type Connectors

AM1A SOLID STATE MIXER-AMPLIFIER MONOPHONIC

The AM1A is a Mixer Amplifier of exceptional quality, being a low level, solid state device, with 24 hour continuous operation reliability designed and built in. The unit, by nature of its solid state, plug-in modular construction, offers great flexibility in choice of operating configuration. Standard equipment includes 4 principal input services (low level) utilizing low impedance microphone preamplifier modules (AM4100), and 2 high impedance input (Strapping Card SC-4401). Each channel has XL type connectors, speech music switches and individual volume control. Master gain control and continuous-type low and high frequency equalization are included. The illuminated VU meter, also included as standard equipment, is certified to National Bureau of Standards and A.S.A. specifications. Input versatility is enhanced by the use of other Langevin plug-in modules and accessory groups.

Two additional auxiliary inputs without Mixer controls offer high

level, high Z service, with one input influenced by the front panel equalizer and master gain controls and the other completely independent of panel controls.

Output services provided include one 600 ohm, ungrounded, principal output, and one 10K ohm auxiliary output. A headphone jack is also included.

The AM1A Mixer service may be expanded by use of the AM2A 9 position microphone mixer. The 9 input AM2A may be powered by the Langevin AM1A Mixer-Amplifier.

The extreme reliability, and great flexibility of the AM1A Mixer-Amplifier and companion AM2A Microphone-Mixer, make them ideal for use in high quality sound reinforcement control and amplification applications. The compact size, solid state construction and light weight also make them highly suitable for portable or remote usage.

Langevin AUDIO EQUIPMENT

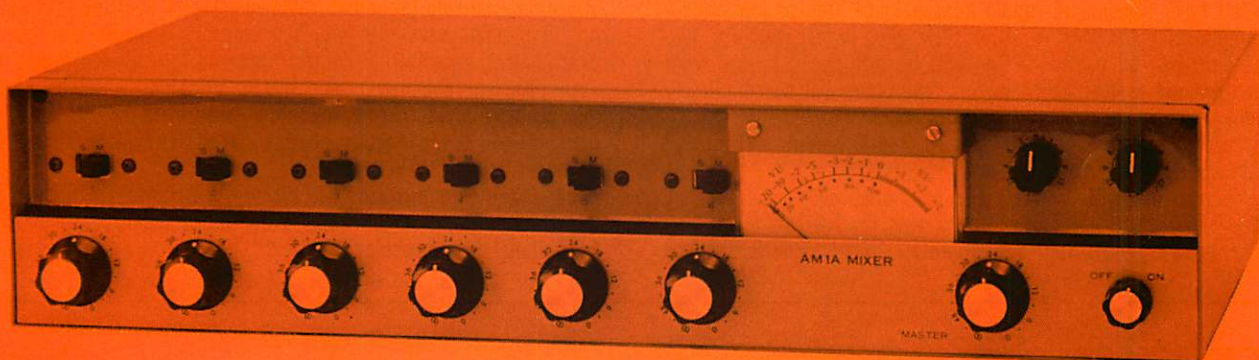

SPECIFICATIONS:

The electrical performance of the AM1A will largely depend on the type or types of Langevin "4000 Series" Input Modules used in it. The following specifications will generally apply.

Gain:	88db nominal. An output of full +4VU may be developed from an input as low as -84dbm. Other types of input modules will require input levels as listed.
Power Output:	+18dbm maximum, +4VU program.
Frequency Response	± 1.0 db over range 30Hz to 15kHz
Input Impedance:	150 to 250 ohm (Standard AM4100) 250K ohm (Accessory AM4300) 250K ohm (Accessory SC4401 Strapping Card) 6000 ohm (Accessory BR4402 Bridging Card). For Bridging or Matching a 150-600 ohm line.
Output Impedance:	600 ohm nominal (Principal output) 10K ohm Monitor or Auxiliary output
Distortion:	Less than 0.25% total harmonic distortion at +18dbm out (1000Hz)
Noise:	-122 dbm equivalent input noise (60db signal-to-noise ratio)
Input Services:	6 principal inputs have XL type connectors, mixer controls, speech music switches 2 auxiliary inputs with no mixer controls. (1 independent of panel controls.)
Mains Requirement:	15 watts from 50/60 Hz mains. More power required if the AC outlet on rear is used. Langevin 9 input AM2A Microphone Mixer may be powered by the AM1A.

Power Supply:	Regulated (Self contained).
AC Outlet:	On rear. Controlled with Front-Panel power switch.
Controls:	6 Mixer, master, equalization high and low, speech-music each principal channel, Power. "AB Molded" composition type, convertible to step-type attenuators.
VU Meter:	Illuminated Meets A.S.A. and National Bureau of Standards specifications.
Size:	17" wide (19" for rack-mounting) 3 1/2" high. 9 1/4" deep overall.
Color Scheme:	Neutral greys.
Mounting:	Rack mounted or surface mounted. In rack mounted position unit can be tilted up or down 15°.
Construction:	

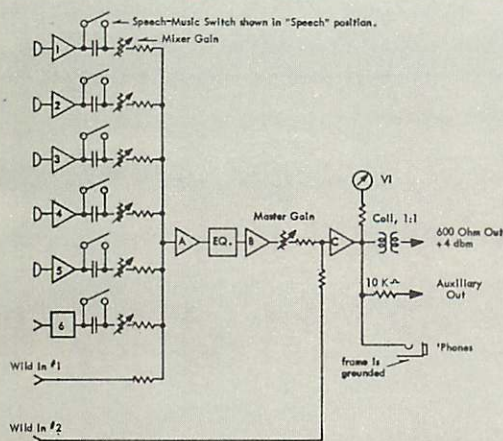
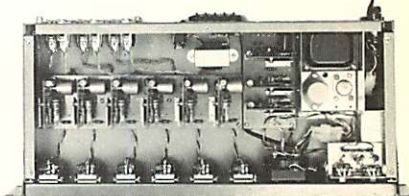

1. Principal Input Channels 1 thru 4 are shown equipped with AM4100 Amplifiers for use with low-Z microphones. Channels 5 & 6 are equipped with high Z input. Other Langevin Series 4000 Modules may be substituted.
2. Amplifier "A" is Langevin AM4300, as is "B". "C" is Langevin AM4700.
3. Power Supply and powering circuits are not shown.
4. The "Wild Inputs" may also be used to feed to an external amplifier.

**BLOCK DIAGRAM
LANGEVIN AM1A
MIXER AMPLIFIER**

ARCHITECTS AND ENGINEERS SPECIFICATIONS

Unit shall be Langevin Model AM1A Mixer Amplifier.

The mixer-amplifier shall be of (choose one) rack mount/portable type. It shall have 6 principal inputs adaptable to high or low impedance microphones by means of solid state plug-in modules. Two auxiliary inputs will be provided. One will be influenced by the front panel equalizer and master gain controls. The other will be completely independent of panel controls.

With a microphone preamplifier type of input module, a gain of at least 88 db will be possible.

Frequency response will be flat within ± 1.0 db over the frequency range 30 Hz to 15 Hz. Distortion will be less than 0.25% total harmonic generation at +18 dbm out (1000Hz). Signal to noise shall be

60 db. Power supply shall be self-contained and regulated. Output service shall include one 600 ohm, neither side grounded and one 10K ohm, one side grounded. Head phone jack shall be included. Mixer Amplifier shall have the following controls: 6 mixer controls, master gain control, equalization control high and low, speech music switches each principal channel, power switch. VU Meter shall be illuminated and shall meet A.S.A. and National Bureau of Standards specifications. Cannon-type XL connectors shall be used. The Mixer Amplifier shall fit in a standard 19 1/2" rack and shall occupy no more than 3 1/2" of panel space with provision for tilting up or down at 15 degree angle. Construction shall be all solid state utilizing silicon planar NPN diffused junction transistors.

ACCESSORIES:

AM4100	Low Z Microphone Pre-Amp (Std in AM1A and AM2A)
AM4101	Low Noise Version of AM4100
AM4300	High Z Microphone Pre-Amp
AM4301	Low Noise Version of AM4300
AM4500	RIAA pre-amplifier module

AM2A	9 Position Microphone Mixer
SC4401	Strapping Card
BC4001	Blank card
BR4402	Bridging input card

