

PLUG-IN AMPLIFIERS

BY
Langevin

TYPE 116-A . . . TYPE 117-A

*Complete Plug-In Audio Facilities
with Only 2 Types of Amplifiers
2 Types of Vacuum Tubes*

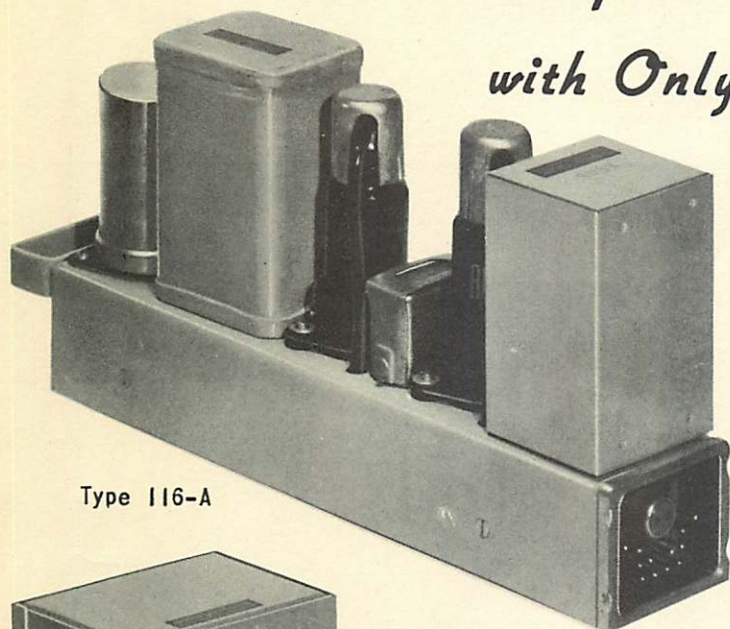

Type 116-A

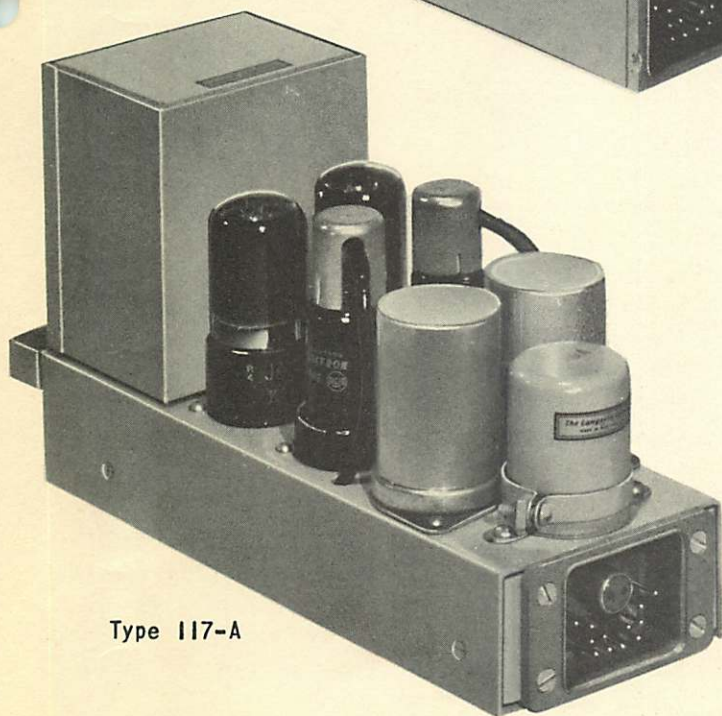

Type 117-A

- STUDIOS STAY IN SERVICE
- LOWER OPERATING COST
- LOWER MAINTENANCE COST
- LOWER INVENTORIES
- RACK SPACE-SAVERS
- AMPLIFIERS EXCEED FCC QUALITY REQUIREMENTS FOR FM
- AMPLIFIERS PROVIDE HIGH OVERLOAD SAFETY FACTOR



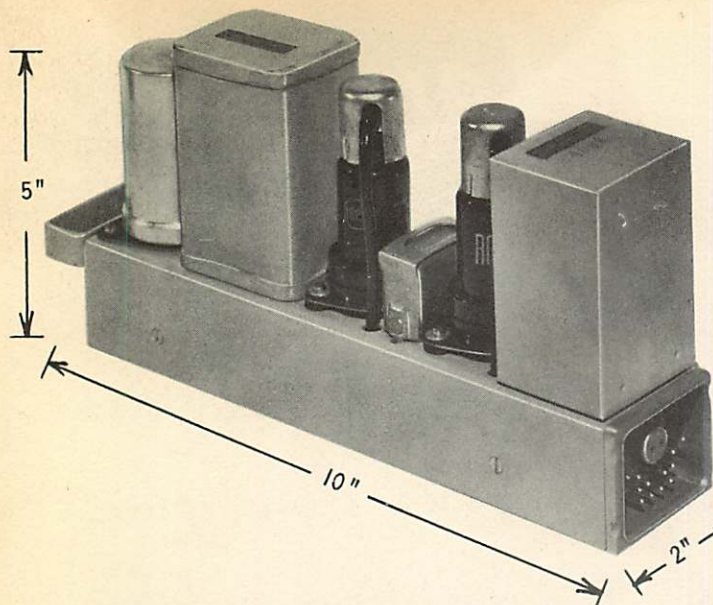

TYPE 116-A

Pre-Amplifier or Booster Amplifier

Electrical Characteristics

GAIN: 40 db with provision for adjusting to 34 db.

TUBE COMPLEMENT: Two 1620.

OUTPUT POWER: +18 DBM (.063 watts) with less than .5% RMS total harmonic distortion over the range 50 to 15,000 cycles, and less than 1% total distortion over the range 30 to 15,000 cycles.

OUTPUT NOISE: Unweighted, equivalent to an input signal of -120 to -124 DBM, depending upon input tube, over the band 50 to 15,000 cycles.

FREQUENCY CHARACTERISTICS: ± 1 db over the range 30 to 15,000 cycles.

INPUT SOURCE IMPEDANCE: 30/150/250/600 Ohms. Center taps are available when strapped for 150 or 600 Ohms.

OUTPUT LOAD IMPEDANCE: 150 or 600 Ohms. Center tap is available when strapped for 600 Ohms.

EXTERNAL POWER REQUIREMENTS: Filament: 6.3 volts AC at 0.6 amperes. Plate: 275 volts DC, 8 Milliamperes.

METERING: Metering connections are available at the plug for external reading of cathode currents of the individual tubes. If it is desired to mount metering switches on the amplifier, knockouts for two Grayhill #4001 push button switches are provided on the rear apron (handle end) of the chassis.

Mechanical Characteristics

SIZE: Length - 10 in., Width - 2 in., Height - 5 in.

WEIGHT: 4 lbs.

SHIPPING WEIGHT: 5-1/2 lbs.

FINISH: Light grey baked enamel over 16 gauge bonderized (rustproofed) steel.

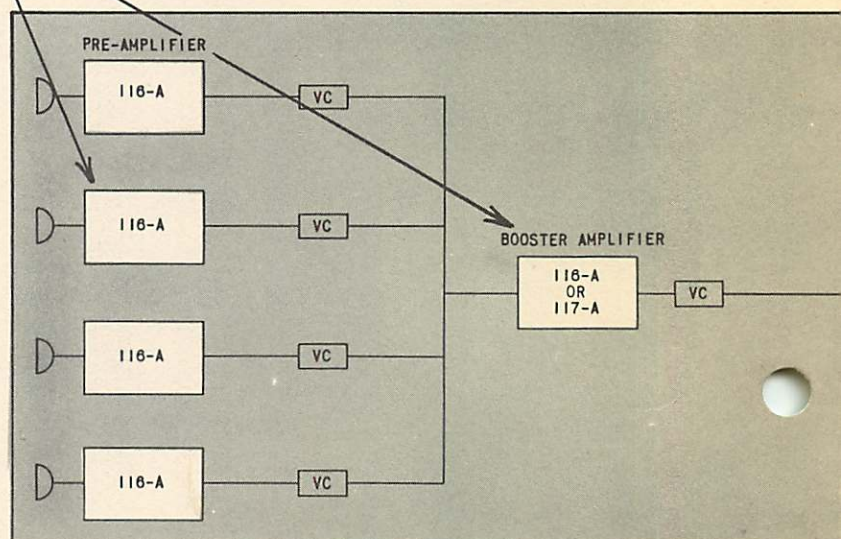

The Langevin Type 116-A and 117-A PLUG-IN amplifiers were designed in conjunction with the General Engineering Department of the Columbia Broadcasting System. These amplifiers are small, versatile, easy-to-use units with better than FM quality performance.

Microphone to Transmitter

Complete broadcast audio facilities can be fabricated with *only* these two amplifiers in the system from microphone to transmitter input, using the Type 116-A as pre-amplifier and booster, and the Type 117-A as program amplifier, booster, and monitor.

Gold Plated Plugs

The amplifiers utilize Cannon Plugs, built to Langevin specifications, with gold-plated, non-oxidizing terminals, and a shielded TWIN-AX input connection. The mating plug receptacle is supplied with each amplifier.

TYPE 117-A

Program, Booster or Monitor Amplifier

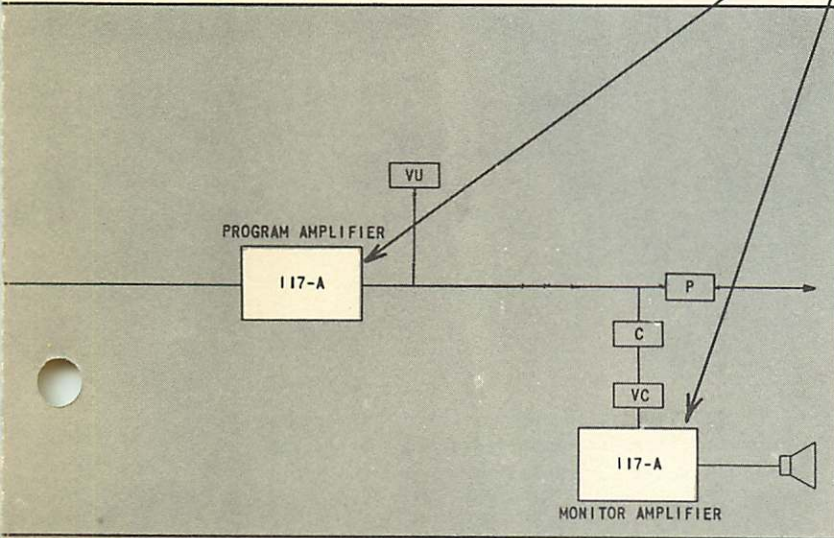
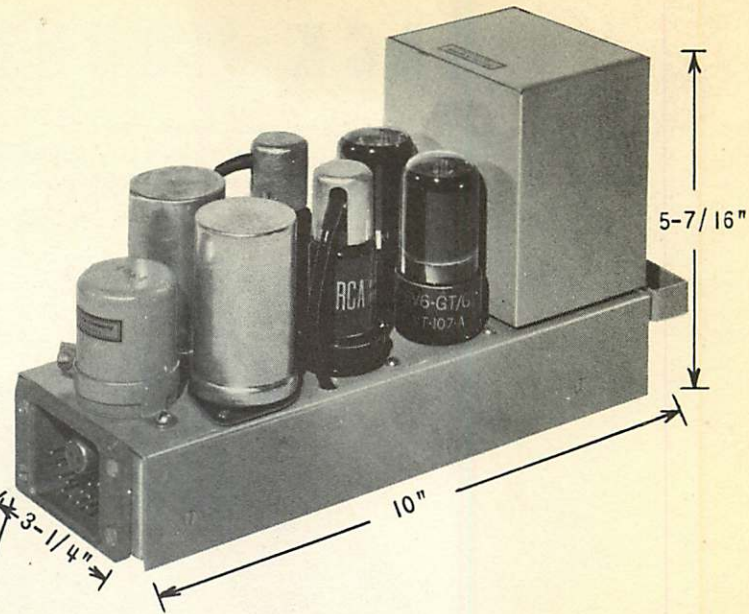

Electrical Characteristics

GAIN: 50 db.

TUBE COMPLEMENT: Two 1620, two 6V6GT.

OUTPUT POWER: +30 DBM (1 watt) with less than .5% RMS total harmonic distortion over the range 50-15,000 cycles and less than 1% total distortion over the range 30-15,000 cycles. As a monitor amplifier, +39 DBM (8 watts) with less than 1% total RMS harmonic distortion over the range 50-10,000 cycles.

OUTPUT NOISE: Unweighted, equivalent to an input signal of -110 to -114 DBM, depending upon tubes, over the band 50 to 15,000 cycles.

FREQUENCY CHARACTERISTIC: ± 1 db over the range 30 to 15,000 cycles.

INPUT SOURCE IMPEDANCE: 30/150/250/600 Ohms.

Center taps are available when strapped for 150 or 600 Ohms.

OUTPUT LOAD IMPEDANCE: 150 or 600 Ohms. Center tap is available when strapped for 600 Ohms.

EXTERNAL POWER REQUIREMENTS: Filament 6.3 Volts AC at 1.5 amperes. Plate: 300 Volts DC at 70 Milliampères.

METERING: Metering connections are available at the plug for external reading of cathode currents of the individual tubes. If it is desired to mount metering switches on the amplifier, knockouts for four Grayhill #4001 push button switches are provided on the rear apron (handle end) of the chassis.

Mechanical Characteristics

SIZE: Length: 10 in., width: 3-1/4 in., height: 5-1/2 in.

WEIGHT: 6-1/2 lbs.

SHIPPING WEIGHT: 8 lbs.

FINISH: Light grey baked enamel over 16 gauge Bonderized (rustproofed) steel.

Small Size

Rack space can be used to the fullest advantage with PLUG-IN amplifiers, as it is possible to mount 6 pre-amplifiers (Type 116-A) or 4 Program amplifiers (Type 117-A) in 7 inches of rack space. (See page four for mounting details). The small physical size of the PLUG-IN units makes them readily adaptable to console installation.

Maintenance Advantages

PLUG-IN amplifiers are easily removed from equipment racks or consoles for preventive maintenance checks at the service bench. Studio operation can be maintained with replacement amplifiers.

Overall Economy

Simplification of broadcast audio facilities to only two types of amplifiers, and only two types of tubes, 1620's and 6V6GT's makes possible station economies by decreasing tube and amplifier inventories.

RACK MOUNTING DETAILS

The Langevin Rack Mounting Assembly for PLUG-IN amplifiers is a unit which occupies only 7 inches of standard equipment rack space, and can accommodate various combinations of the two types of amplifiers.

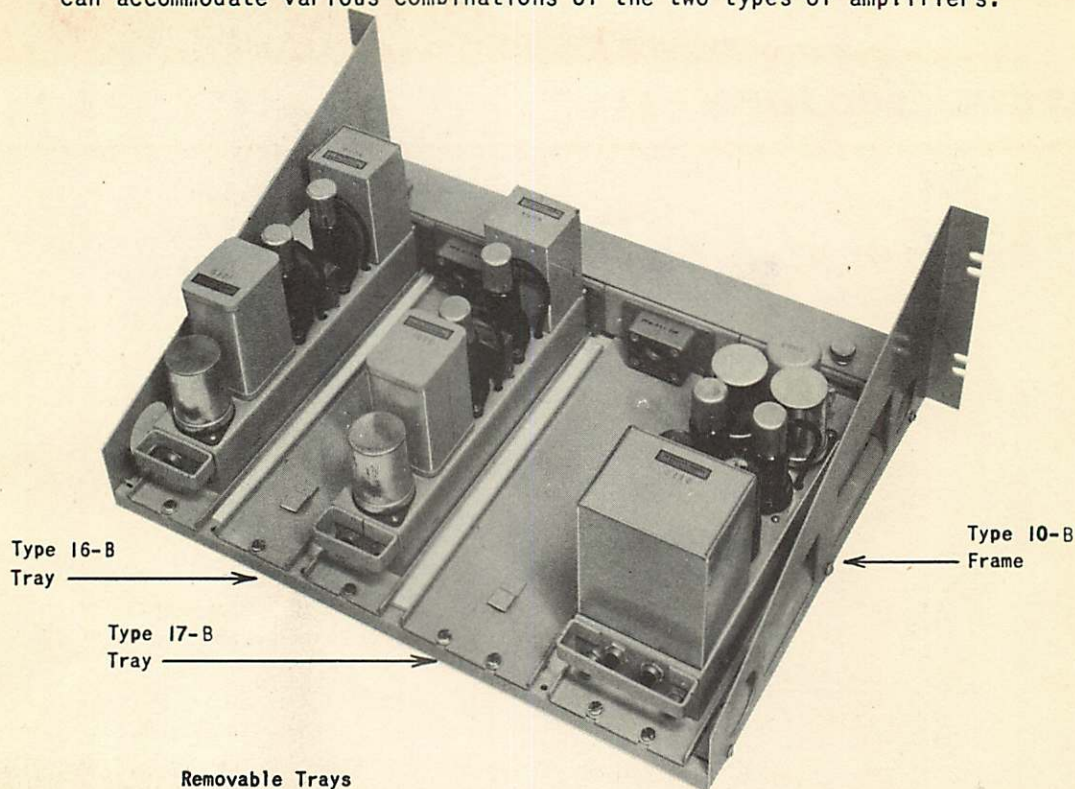

Removable Trays

The assembly is constructed with two sizes of removable trays, Type 16-B and Type 17-B, each having a plug receptacle mounted on it. Trays may be arranged on the basic frame, Type 10-B, so that the following combinations of amplifiers can be achieved:

- Six Type 116-A Pre-Amplifiers
or
- Four Type 117-A Program Amplifiers.
or
- Three Type 116-A Pre-Amplifiers
and two Type 117-A Program Amplifiers.
or
- Four Type 116-A Pre-Amplifiers
and one Type 117-A Program Amplifier.

Power Supply

A Selenium Rectifier power supply by Langevin is available to provide plate and filament power for the 116-A and 117-A PLUG-IN amplifiers.

The 205-A power supply has a maximum rating of 425 Milliamperes. With the secondary tap set for "high" output voltage, the following is available:

In the illustration above, trays for a combination of three pre-amplifiers and two program amplifiers have been assembled on the basic frame. The assembly, as shown, will allow removal of the amplifiers from the rear of an equipment rack. However, if it is desired to plug the amplifiers in from the front side of a rack, the mounting trays can be reversed on the basic frame.

Cabling

All cabling is run through the channel located directly behind the plug receptacles, and a removable cover over the cable channel allows easy access to the plugs for wiring purposes.

Overall Specifications

Height: 7 in. Width: 16-3/4 in. Depth: 13 in.
Weight: 10 lbs.

275 Milliamperes at 300 Volts D.C.
150 Milliamperes at 275 Volts D.C. (Through an additional stage of filtering for the pre-amplifiers).

With the secondary tap set for "low" output voltage, 425 Milliamperes at 225V. D.C. are available for the operation of twelve of the Langevin Type 118-A Isolation-Bridging PLUG-IN amplifiers.

Grounding

Connect ground to pin number 3 on the plug for the negative side of the plate supply. When only one amplifier is being used, connect pin number 13 to pin number 3. When several amplifiers are used in a system, and obtain plate power from a transformer, apply the ground at only one point.

The center tap of the power supply should be connected to ground in most cases, however, it may be necessary to connect it to the filament center tap with a resistor in order to reduce hum caused by filament sag. In this event, a resistance can be connected between the plate voltage supply so that a filament voltage, 5 to 12 volts, can be tapped from the filament center tap.

Impedance

The amplifier, as shipped, is connected to work with an impedance of 300 Ohms and into a load impedance of 300 Ohms. If other impedances are desired, the amplifier can be re-strapped according to the table in the manual. Strapping for the input is accomplished on the resistor strip; for the output on the output transformer.

Reduced Plate Voltage

When the amplifier is used as a program or booster, the plate voltage may be reduced to 275 volts. This will result in a current drain of approximately 65 MA without a significant loss of output power...thus prolonging the life of the tube.

Center Taps

The center tap of the input transformer is available on the input of the 117-A unit. It is strapped for 150 or 300 Ohms, or it can be strapped for 600 Ohms. The input is grounded on the resistor strip. In the case of the output center tap, run an additional ground point to the output transformer terminal.

Tube Substitutions

In an emergency, if the 1620 vacuum tube is not available, a 6J7 tube can be substituted. This substitution may result in a decrease in output power and an increase in output noise level.

Power Supplies

Four types of power supplies providing plate and filament power are available for operation of the Langevin 117-A Amplifier (and 116-B Amplifier), three of which are plug-in types. The electrical characteristics and mounting details of these four types are tabulated below:

TYPE	AC LINE SUPPLY	PLATE SUPPLY	FILAMENT SUPPLY	RECTIFIER TYPE	MOUNTING	MOUNTING ACCESSORIES
205-B	100-130V 200/260V 50/60cycles	425 ma. max. at 220 to 300V 150 ma. max. at 180 to 260V	2 @ 6.3V 8 amps.	Selenium Cell	Rack (10½")	36F Hat Panel (Supplied)
206-B	105-125V 210-250V 50/60cycles	210 ma. max. at 270 to 350V	6.3V 8 amps.	Selenium Cell	Plug-in	19-A Mounting Tray on 10-B Mounting Frame 33-S Receptacle
208-A	105-125V 50/60cycles	110 ma. max. at 275V	6.3V 8 amps.	5Y3GT Tube	Plug-in	17-B Mounting Tray on 10-B Mounting Frame 33-S Receptacle
210-A	105-125V 210-250V 50/60cycles	425 ma. max. at 300V	2 @ 6.3V 8 amps.	Selenium Cell	Plug-in	20-A Mounting Tray on 10-B Mounting Frame 33-S Receptacle

Mounting Accessories

All Langevin PLUG-IN Amplifiers and Power Supplies are designed to mount in Mounting Trays equipped with bracket for attaching the 33-S Receptacle. These trays mount on a 10-B Mounting Frame, which occupies 7" of standard rack space. The 117-A Amplifier requires a 17-B Mounting Tray; the 116-B Amplifier requires the 16-B Mounting Tray. The 10-B Mounting Frame will accommodate six 116-B Amplifiers, or four 117-A Amplifiers or various combinations of both.

Because of noise pick-up, it is recommended that no power supply be mounted on the same mounting frame with amplifiers. A 10-B Mounting Frame will accommodate four 208-A Power Supplies, two 206-B Power Supplies or one 210-A Power Supply.

Mounting accessories and receptacles are not supplied with amplifiers and power supplies; they should be ordered separately.

- REVISIONS
- (2) L.V.A. 6-1-55
Dwg. No. WAS
A-2989 M.L.
 - (3) J.T. 12-11-56
REVISED VT-2,3,4
 - (4) IM 9-29-59
ADDED SW-1-4 PERIM.
 - (5) ADDED C-5/C-6
9-26-61 d.m.c.

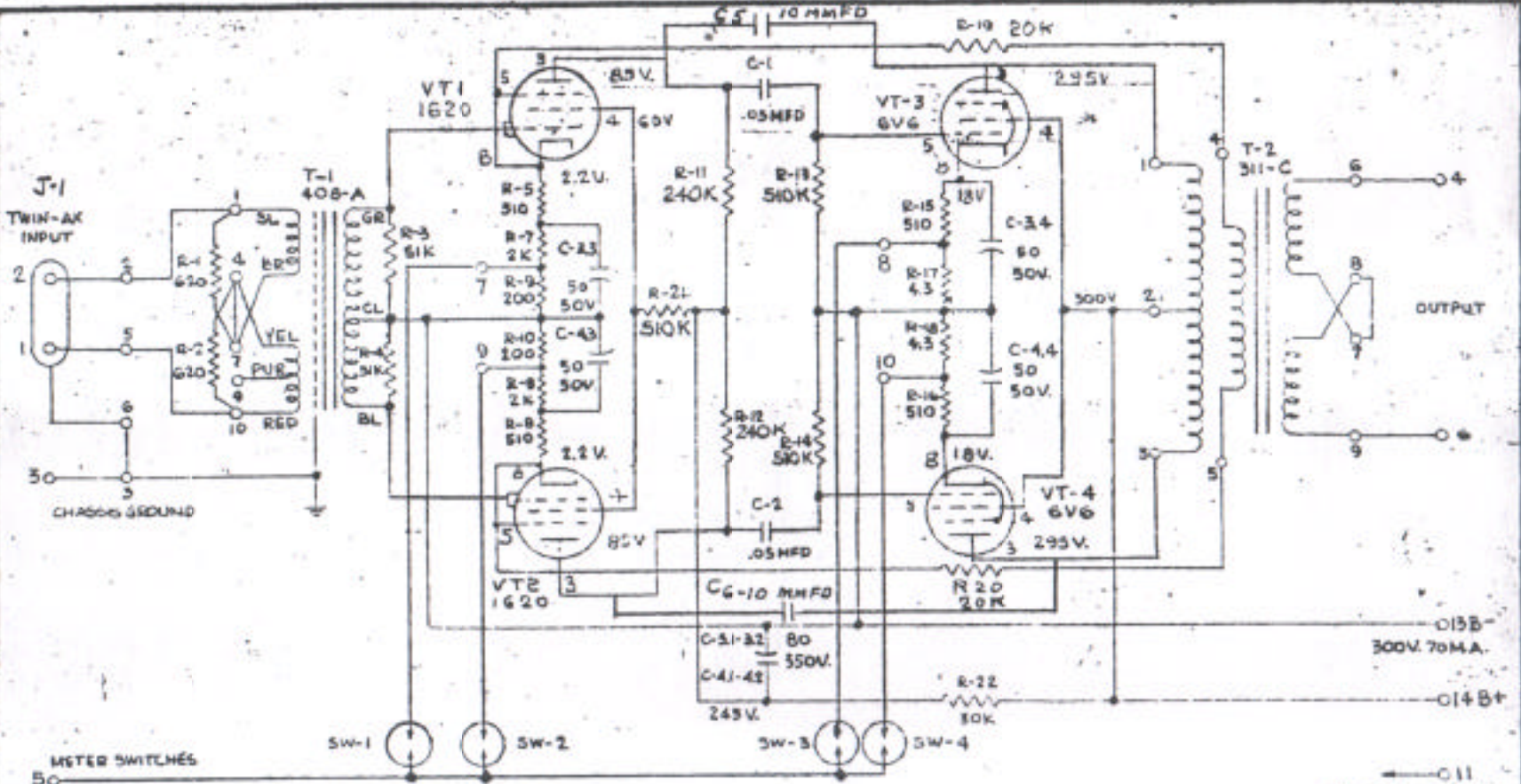

SCHEMATIC DIAGRAM
117-A AMPLIFIER

INPUT IMPEDANCE

600Ω
250Ω
150Ω
50Ω

STRAPPING ON RESISTOR STRIP

1-2, 4-7, 8-10
1-2, 4-7, 5-9
1-2-4, 5-7-10
2-9, 8-10

OUTPUT IMPEDANCE

600Ω
150Ω

STRAPPING ON OUTPUT TRANSFORMER

7-6
6-8, 7-9

← O11
FIL. 6.3V. A.C. 1.5A
← O12

NOTE: THE VOLTAGES SHOWN ARE TYPICAL AVERAGE VALUES OBTAINED USING A 11 MEGOHM VOLTMETER WITH NO SIGNAL INPUT AND CONNECTED TO POWER SUPPLIES INDICATED. VOLTAGES ARE IN REFERENCE TO B-

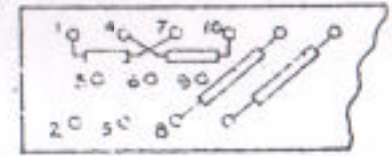

RESISTOR STRIP NUMBERING

DR. BY *U.C.*
CK. BY
SCALE
THE
LANGVIN CO.
NEW YORK
DR. NO. *AV117-A-5*
DATE 5-27-69
ENGR.